

SPASHOME

SPASHOME

treesse

treesse

Fonte d'ispirazione, l'acqua non è una forma, è trasparenza, è sensazione, è viaggio nel passato. Evolvendosi, si declina in molteplici interpretazioni per regalarvi esperienze sensoriali a tutto tondo; riflettendo, disegna le atmosfere del relax, dando vita ad un programma innovativo di vasche e docce multifunzionali pensate esclusivamente per voi: in sintesi, Spa&Home.

Water is a source of inspiration. Yet it is not a form. Water is transparency. It's a sensation. It's a journey back in time. Ever shifting, water expresses itself in a myriad of ways to regale you with experiences for all your senses. Water reflects and shapes relaxing atmospheres, inspiring an innovative program of multi-functional bathtubs and showers designed just for you. This is Spa&Home.

**treesse**  
MADE IN ITALY

Source d'inspiration, l'eau n'est pas une forme: elle est transparence, sensation, voyage dans le passé. En évoluant, elle se décline en maintes interprétations pour offrir quantité d'expériences sensorielles; par sa manifestation, elle crée des atmosphères relaxantes et est à l'origine d'un programme novateur de baignoires et de douches multifonctionnelles, spécialement conçu pour vous: Spa&Home.

Fuente de inspiración, el agua no es una forma, es transparencia, sensación, es un viaje al pasado. Al evolucionar se declina en múltiples interpretaciones para regalarte experiencias sensoriales completas; al reflejarse, diseña las atmósferas del relax y da vida a un programa innovador de bañeras y duchas multifuncionales pensadas exclusivamente para ti: Spa&Home.



treesse **SPA** MYTHERME SYSTEM

- 8 *Bis mts*
- 16 *Quadra mts*
- 22 *Vision mts*



treesse **HOME**

*GRANDI VASCHE*

- Large bathtubs*
- Grandes baignoires*
- Grandes bañeras*

*VASCHE ANGOLARI*

- Corner bathtubs*
- Baignoires angulaires*
- Bañeras angulares*

*VASCHE RETTANGOLARI*

- Rectangular bathtubs*
- Baignoires rectangulaires*
- Bañeras rectangulares*

*VASCHE SPECIALI*

- Special bathtubs*
- Baignoires spéciales*
- Bañeras especiales*

*BOX DOCCIA*

- Shower cubicles*
- Cabines de douche*
- Cabinas de ducha*

- 48 *Bis*
- 52 *Bis line*
- 54 *Bis one top*
- 56 *Bis one steel*
- 62 *Inside*
- 68 *Matrix slim*
- 72 *Matrix midi*
- 74 *Matrix top*
- 82 *Ninfa*
- 86 *Perla*

- 92 *Asyx*
- 96 *Dafne*
- 98 *Dafne box*
- 104 *Haiti*
- 108 *Slide*

- 116 *Alba*
- 120 *Alba box*
- 122 *Alba box easy*
- 128 *Crystal line*
- 132 *New classic*
- 136 *New classic young*
- 142 *Playa*
- 148 *Quadra*
- 154 *Quadra line*
- 156 *Quadra box*
- 158 *Quadra box easy*
- 166 *Spider*
- 172 *Thesis*
- 178 *Vision*

- 188 *Calypso*
- 192 *Crystal*
- 198 *Epoca*
- 206 *Epoca egg*
- 216 *Epoca one top*
- 220 *Gen-x*
- 228 *Milo*
- 234 *Moulin*
- 238 *Niña*

- 246 *Dada*
- 252 *Elle*
- 266 *Flat*
- 282 *Idea*
- 292 *Pack*
- 306 *Stone midi*
- 310 *Stone top*
- 316 *Stone tria*



Progetto Prof. Antonello Ancillai

**MYTHERME**  
SYSTEM

MyTherme System è la novità che cambia l'idromassaggio  
e il modo di pensare il benessere.

La comodità e il piacere di un bagno termale in casa:  
un privilegio mai provato, assolutamente da provare.

The innovation of MyTherme System is changing hydromassage  
and our very way of conceiving wellness.

The ease and pleasure of a hydrothermal spa at home.  
A privilege like no other and a must-have experience.

MyTherme System, une nouveauté en matière d'hydromassage  
et dans sa façon d'appréhender le bien-être.

Tout le confort et le plaisir d'un bain thermal chez soi:  
un privilège inédit, à essayer absolument.

MyTherme System es la novedad que cambia el hidromasaje  
y la forma de entender el bienestar.

La comodidad y el placer de un baño termal en tu propia casa:  
un privilegio nunca antes experimentado y que vale la pena probar.

PARA

*Bis mts*  
190 X 150 X 65h.



Page 8

*Quadra mts*  
180 X 95 X 63/65h.  
180 X 115 X 59/61h.



16

*Vision mts*  
180 X 80 X 60h.



22

*Bis*  
MYTHERME SYSTEM  
designer Paolo Parea

190 X 150 X 65h.









Bis mts  
190 X 150 X 65h.

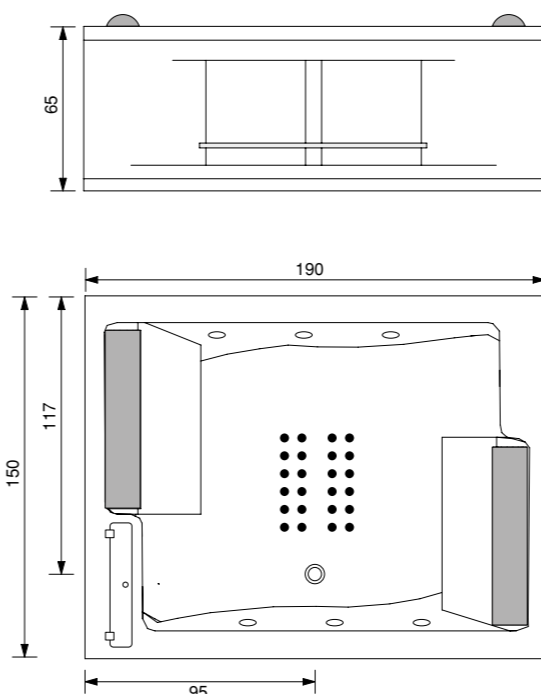

**DOTAZIONI E OPTIONAL**

- DOPPIA SEDUTA INTERNA
- POGGIATESTA RIALZATI CON CUSCINO
- MANIGLIE DI SOSTEGNO
- IMPIANTO TERMALE MYTHERME SYSTEM
- MAGNETIZZAZIONE DELLE ACQUE
- KIT DI RICARICA SOLUZIONI SALI MINERALI
- KIT DI RICARICA OLII ESSENZIALI
- IDROMASSAGGIO
- AIRPOOL
- SENSORE DI LIVELLO
- IMPIANTO DI DISINFEZIONE
- STABILIZZATORE TEMPERATURA ACQUA
- CROMOTERAPIA
- FARO
- RADIO
- INGRESSO AUDIO PER IPOD/CD
- OZONO TERAPIA
- RUBINETTERIA BORDO VASCA
- TELECOMANDO PER CONTROLLO FUNZIONI

**FOURNITURES ET OPTIONS**

- DOUBLE ASSISE INTERNE
- REPOSE-TETE REHAUSSES AVEC COUSSIN
- POIGNEES DE SOUTIEN
- INSTALLATION THERMALE MYTHERME SYSTEM
- MAGNETISATION DES EAUX
- KIT DE RECHARGE SOLUTIONS SELS MINERAUX
- KIT DE RECHARGE HUILES ESSENTIELLES
- HYDROMASSAGE
- AIRPOOL
- CAPTEUR DE NIVEAU
- INSTALLATION DE DESINFECTION
- STABILISATEUR TEMPERATURE DE L'EAU
- CHROMOTHERAPIE
- SPOT
- RADIO
- ENTREE AUDIO POUR IPOD/CD
- OZONOTHERAPIE
- ROBINETTERIE REBORD DE BAIGNOIRE
- TELECOMMANDE POUR CONTROLE DES FONCTIONS

**FEATURES AND OPTIONALS**

- INTERNAL TWIN SEATS
- RAISED HEADRESTS WITH CUSHION
- GRAB BARS
- MYTHERME SYSTEM SPA
- WATER MAGNETIZATION
- MINERAL SALT REFILL KIT
- ESSENTIAL OIL REFILL KIT
- HYDROMASSAGE
- AIRPOOL
- LEVEL SENSOR
- DISINFECTION SYSTEM
- WATER TEMPERATURE STABILIZER
- COLOR THERAPY
- SPOTLIGHT
- RADIO
- AUDIO INPUT FOR IPOD/CD
- OZONE THERAPY
- TUB EDGE FAUCETS
- REMOTE CONTROL FOR FUNCTIONS

**CARACTERÍSTICAS Y COMPLEMENTOS**

- DOBLE ASIENTO INTERIOR
- REPOSACABEZAS ELEVADOS CON COJÍN
- ASIDEROS DE APOYO
- SISTEMA TERMAL MYTHERME SYSTEM
- MAGNETIZACIÓN DEL AGUA
- KIT DE RECARGA DE SOLUCIONES SALINAS
- KIT DE RECARGA DE ACEITES ESENCIALES
- HIDROMASAJE
- AIRPOOL
- SENSOR DE NIVEL
- SISTEMA DE DESINFECCIÓN
- ESTABILIZADOR DE LA TEMPERATURA DEL AGUA
- CROMOTERAPIA
- LUZ
- RADIO
- ENTRADA DE AUDIO PARA IPOD/CD
- OZONOTERAPIA
- GRIFERÍA EN EL BORDE DE LA BAÑERA
- MANDO A DISTANCIA PARA CONTROL DE LAS FUNCIONES



# Quadra

MYTHERME SYSTEM  
designer Paolo Parea

180 X 95 X 63/65h. 180 X 115 X 59/61h.

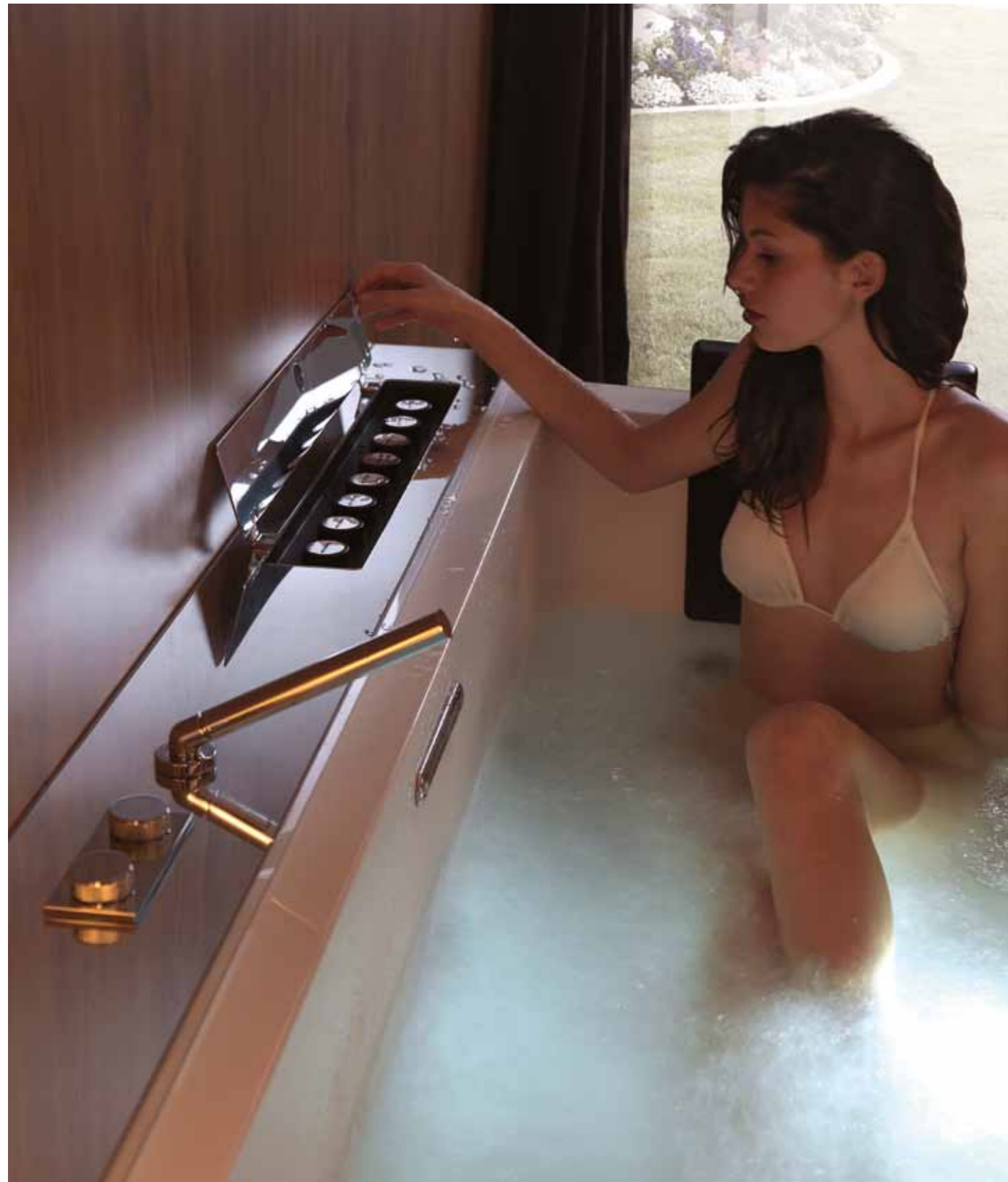



## Quadra mts

180 X 95 X 63/65h. 180 X 115 X 59/61h.

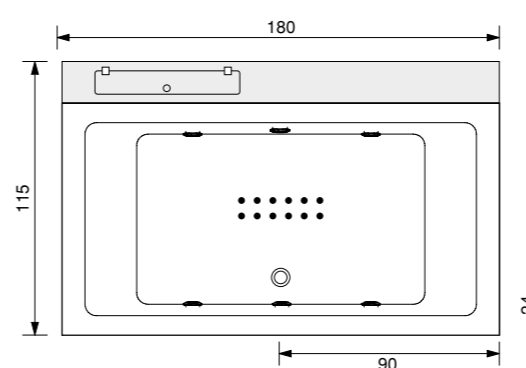
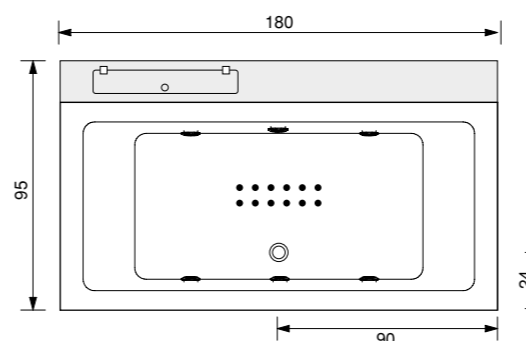

### DOTAZIONI E OPTIONAL

- STRUTTURA IN LAMINATO ACRILICO A SPECCHIO
- CUSCINI POGGIATESTA
- IMPIANTO TERMAL MYTHERME SYSTEM
- MAGNETIZZAZIONE ACQUE
- KIT DI RICARICA SOLUZIONI SALI MINERALI
- KIT DI RICARICA OLII ESSENZIALI
- IDROMASSAGGIO
- AIRPOOL
- SENSORE DI LIVELLO
- IMPIANTO DI DISINFEZIONE
- STABILIZZATORE TEMPERATURA ACQUA
- CROMOTERAPIA
- FARO
- RADIO
- INGRESSO AUDIO PER IPOD/CD
- OZONO TERAPIA
- RUBINETTERIA BORDO VASCA
- TELECOMANDO PER CONTROLLO FUNZIONI

### FOURNITURES ET OPTIONS

- STRUCTURE EN LAMINE ACRYLIQUE BRILLANT
- COUSSINS REPOSE-TETE
- INSTALLATION THERMALE MYTHERME SYSTEM
- MAGNETISATION DES EAUX
- KIT DE RECHARGE SOLUTIONS SELS MINERAUX
- KIT DE RECHARGE HUILES ESSENTIELLES
- HYDROMASSAGE
- AIRPOOL
- CAPTEUR DE NIVEAU
- INSTALLATION DE DESINFECTION
- STABILISATEUR TEMPERATURE DE L'EAU
- CHROMOTHERAPIE
- SPOT
- RADIO
- ENTREE AUDIO POUR IPOD/CD
- OZONOTHERAPIE
- ROBINETTERIE REBORD DE BAIGNOIRE
- TELECOMMANDE POUR CONTROLE DES FONCTIONS

### FEATURES AND OPTIONALS

- STRUCTURE OF REFLECTIVE ACRYLIC LAMINATE
- HEADREST CUSHIONS
- MYTHERME SYSTEM SPA
- WATER MAGNETIZATION
- MINERAL SALT REFILL KIT
- ESSENTIAL OIL REFILL KIT
- HYDROMASSAGE
- AIRPOOL
- LEVEL SENSOR
- DISINFECTION SYSTEM
- WATER TEMPERATURE STABILIZER
- COLOR THERAPY
- SPOTLIGHT
- RADIO
- AUDIO INPUT FOR IPOD/CD
- OZONE THERAPY
- TUB EDGE FAUCETS
- REMOTE CONTROL FOR FUNCTIONS

### CARACTERÍSTICAS Y COMPLEMENTOS

- ESTRUCTURA DE LAMINADO ACRÍLICO EFECTO ESPEJO
- COJINES REPOSACABEZAS
- SISTEMA TERMAL MYTHERME SYSTEM
- MAGNETIZACIÓN DEL AGUA
- KIT DE RECARGA DE SOLUCIONES SALINAS
- KIT DE RECARGA DE ACEITES ESENCIALES
- HIDROMASAJE
- AIRPOOL
- SENSOR DE NIVEL
- SISTEMA DE DESINFECCIÓN
- ESTABILIZADOR DE LA TEMPERATURA DEL AGUA
- CROMOTERAPIA
- LUZ
- RADIO
- ENTRADA DE AUDIO PARA IPOD/CD
- OZONOTERAPIA
- GRIFERÍA EN EL BORDE DE LA BAÑERA
- MANDO A DISTANCIA PARA CONTROL DE LAS FUNCIONES



# Vision

MYTHERME SYSTEM  
designer Paolo Parea

180 X 80 X 60h.











## Vision mts

180 X 80 X 60h.

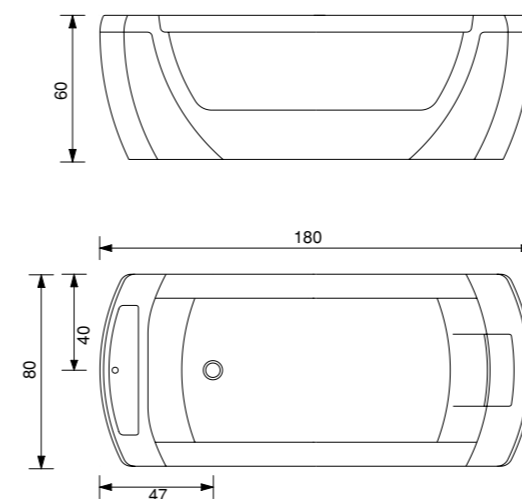

### DOTAZIONI E OPTIONAL

- BRACCIOLI E POGGIATESTA INTEGRATI
- PARETI LATERALI IN CRISTALLO VISARM
- VANO CON SPORTELLO
- SCARICO A PULSANTE
- IMPIANTO TERMALE MYTHERME SYSTEM
- MAGNETIZZAZIONE ACQUE
- KIT DI RICARICA SOLUZIONI SALI MINERALI
- KIT DI RICARICA OLII ESSENZIALI
- IDROMASSAGGIO
- AIRPOOL
- SENSORE DI LIVELLO
- IMPIANTO DI DISINFEZIONE
- STABILIZZATORE TEMPERATURA ACQUA
- CROMOTERAPIA
- FARO
- RADIO
- INGRESSO AUDIO PER IPOD/CD
- OZONO TERAPIA
- RUBINETTERIA BORDO VASCA
- TELECOMANDO PER CONTROLLO FUNZIONI

### FOURNITURES ET OPTIONS

- ACCOUDOIRS ET REPOSE-TETE INTEGRES
- PAROIS LATERALES EN VERRE STRATIFIE INCASSABLE
- COMPARTIMENT AVEC PORTE
- EVACUATION A BOUTON
- INSTALLATION THERMALE MYTHERME SYSTEM
- MAGNETISATION DES EAUX
- KIT DE RECHARGE SOLUTIONS SELS MINERAUX
- KIT DE RECHARGE HUILES ESSENTIELLES
- HYDROMASSAGE
- AIRPOOL
- CAPTEUR DE NIVEAU
- INSTALLATION DE DESINFECTION
- STABILISATEUR TEMPERATURE DE L'EAU
- CHROMOTHERAPIE
- SPOT
- RADIO
- ENTREE AUDIO POUR IPOD/CD
- OZONOTHERAPIE
- ROBINETTERIE REBORD DE BAIGNOIRE
- TELECOMMANDE POUR CONTROLE DES FONCTIONS

### FEATURES AND OPTIONALS

- BUILT-IN ARM AND HEADREST
- SIDE WALLS IN LAMINATED SAFETY GLASS
- COMPARTMENT WITH HATCH
- BUTTON DRAIN
- MYTHERME SYSTEM SPA
- WATER MAGNETIZATION
- MINERAL SALT REFILL KIT
- ESSENTIAL OIL REFILL KIT
- HYDROMASSAGE
- AIRPOOL
- LEVEL SENSOR
- DISINFECTION SYSTEM
- WATER TEMPERATURE STABILIZER
- COLOR THERAPY
- SPOTLIGHT
- RADIO
- AUDIO INPUT FOR IPOD/CD
- OZONE THERAPY
- TUB EDGE FAUCETS
- REMOTE CONTROL FOR FUNCTIONS

### CARACTERÍSTICAS Y COMPLEMENTOS

- REPOSABRAZOS Y REPOSACABEZAS INTEGRADOS
- PAREDES LATERALES DE CRISTAL ESTRATIFICADO IRROMPIBLE
- COMPARTIMENTO CON PUERTA
- PULSADOR DE VACIADO
- SISTEMA TERMAL MYTHERME SYSTEM
- MAGNETIZACIÓN DEL AGUA
- KIT DE RECARGA DE SOLUCIONES SALINAS
- KIT DE RECARGA DE ACEITES ESENCIALES
- HIDROMASAJE
- AIRPOOL
- SENSOR DE NIVEL
- SISTEMA DE DESINFECCIÓN
- ESTABILIZADOR DE LA TEMPERATURA DEL AGUA
- CROMOTERAPIA
- LUZ
- RADIO
- ENTRADA DE AUDIO PARA IPOD/CD
- OZONOTERAPIA
- GRIFERÍA EN EL BORDE DE LA BAÑERA
- MANDO A DISTANCIA PARA CONTROL DE LAS FUNCIONES

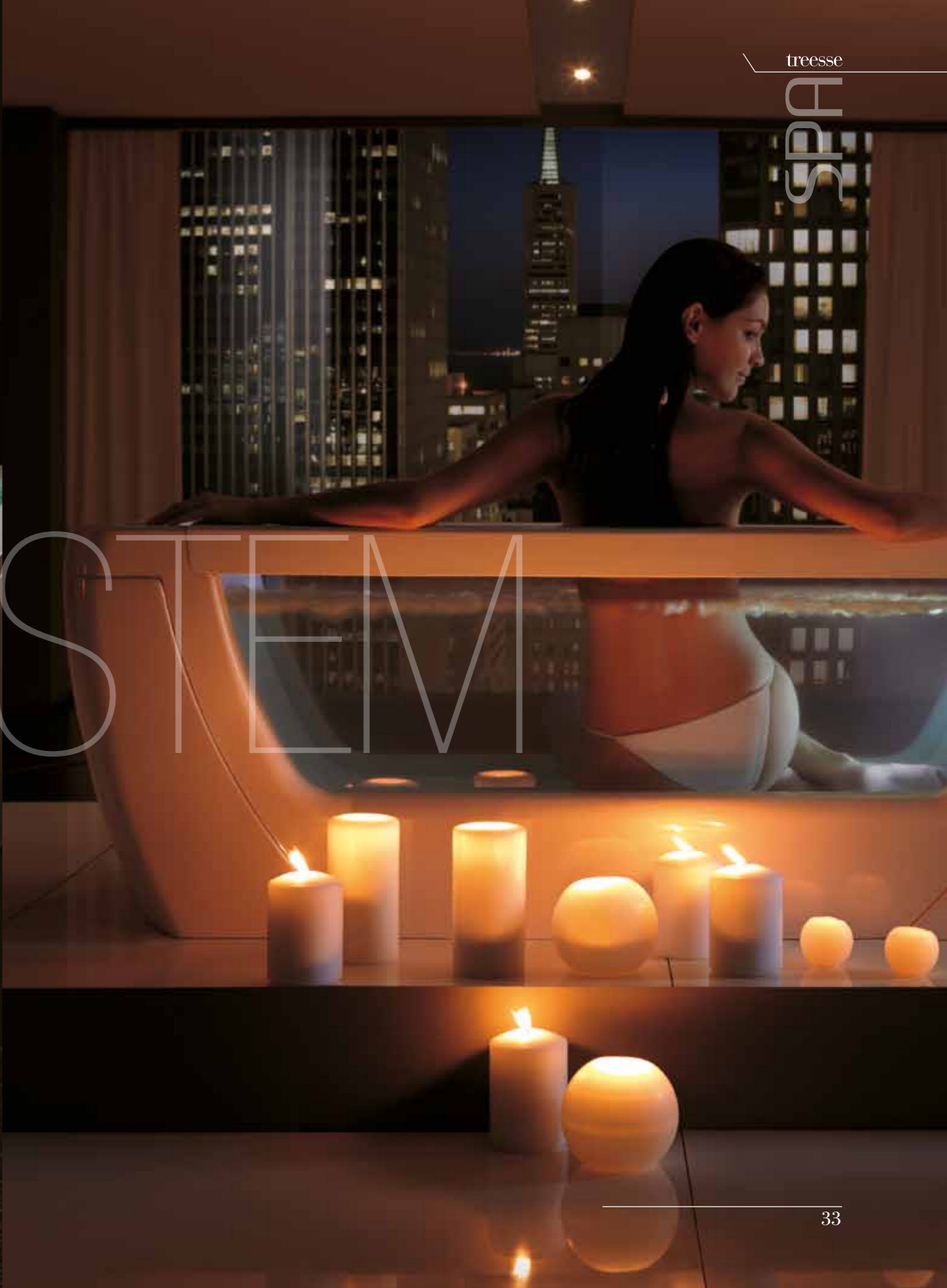

# MYTHERMIA SYSTEM

LE TERME A CASA TUA.

L'idea alla base di tutto: ricreare nel modo

più fedele e benefico possibile le caratteristiche chimico-fisiche delle acque termali e i loro benefici, nella vasca di casa.

Le soluzioni saline contengono gli elementi presenti

nelle acque termali, ricche di proprietà benefiche

con effetti rilassanti, nutrienti e attivanti.

Le diverse combinazioni di questi elementi creano 6 miscele,

6 tipi diversi di acque termali,

ognuna con le sue virtù e azioni specifiche.

L'aggiunta di oli essenziali naturali a base vegetale,

esalta gli effetti delle soluzioni saline, creando una sinergia

che non è presente in nessuna acqua termale.

Ad esempio, l'olio essenziale di Camomilla o di Lavanda

per accentuare gli effetti rilassanti, quello di Menta Piperita

o di Salvia per un bagno tonificante, quello di Geranio

o di Pompelmo per un bagno defaticante.

**Programma 1: RILASSANTE**

Le acque salse, cloruro-sodiche solfate sono ideali

per un benefico rilassamento, con piacevoli sensazioni antistress.

Effetti: distensivo, riposante, decontratturante.

Oli essenziali contenuti: Arancia dolce, Lavanda, Melissa, Ylang-Ylang.

**Programma 2: RIEQUILIBRANTE**

Le acque salse, litiose con microelementi aiutano a ritrovare

il naturale equilibrio, con un effetto lenitivo e calmante.

Effetto: mitigante, antinfiammatorio.

Oli essenziali contenuti:

Arancia dolce, Lavanda, Melissa, Ylang-Ylang.

**Programma 3: TONIFICANTE**

Le acque bromo-iodiche con microelementi sono una fonte

di energia naturale e vitale per il corpo e per la mente.

Effetto: tonicizzante, ricaricante, energizzante, riattivante.

Oli essenziali contenuti: Timo, Salvia, Rosmarino, Menta.

**Programma 4: STIMOLANTE**

Le acque salse bromo-iodiche si rivelano un aiuto

prezioso per migliorare e riattivare la circolazione.

Effetto: rigenerante, rimodellante.

Oli essenziali contenuti: Timo, Salvia, Rosmarino, Menta.

**Programma 5: DEFATICANTE**

Le acque salse e bicarbonato sono ideali

per gli sportivi o dopo un'intensa attività fisica.

Effetto: analgesico, antidolorifico,

facilitazione del riassorbimento edematoso.

Oli essenziali contenuti: Cipresso, Pompelmo, Timo, Geranio.

**Programma 6: DISTENSIVO**

Le acque bromo-iodiche aiutano a creare un piacevole e benefico relax.

Effetto: antireumatico, antiartritico, antinevritico, posttraumatico.

Oli essenziali contenuti: Cipresso, Pompelmo, Timo, Geranio.

A MINERAL SPA IN YOUR VERY OWN HOME.

The essential idea is to recreate in a home bathtub,

as closely as possible,

the physical features and contents of spa waters and their benefits.

The saline solutions have the same elements as spa waters,

replete with properties that promote health with relaxing,

nourishing and energizing effects.

The combinations of these elements create six mixtures,

six different types of spa waters,

each with its own specific effects and powers.

The addition of plant-based, natural essential oils enhances

the effects of the saline solutions, joining forces

for an effect beyond that of any spa water.

For example, the essential oil of chamomile or lavender

can accentuate the effects of a relaxing bath; mint or sage

for an invigorating bath; and geranium or grapefruit

essences for an energizing bath.

**Program 1: RELAXING**

Saline waters, sodium-chloride sulfates are perfect for a relaxing action

and wonderful stress-relieving sensations.

Effects: fatigue-relieving, restful, tension-relieving.

Essential oils: sweet orange, lavender, lemon-balm, ylang-ylang.

**Program 2: RESTORATIVE**

Lithia and saline waters with microelements help you regain your natural balance,

with a soothing, healing effect.

Effect: pain alleviating, anti-inflammatory.

Essential oils: sweet orange, lavender, lemon-balm, ylang-ylang.

**Program 3: INVIGORATING**

Bromide-iodide waters with microelements are a source of natural,

vital energy for your body and mind.

Effect: invigorating, energizing, revitalizing.

Essential oils: thyme, sage, rosemary, mint.

**Program 4: ENERGIZING**

Bromide-iodide saline waters are an invaluable aid to improve

and renew circulation.

Effect: reinvigorating, firming.

Essential oils: thyme, sage, rosemary, mint.

**Program 5: FATIGUE-RELIEVING**

Saline waters and bicarbonates are perfect for athletes

and after intense workouts.

Effect: pain-relieving,

facilitates reabsorption of retained fluids.

Essential oils: cypress, grapefruit, thyme, geranium.

**Program 6: RESTFUL**

Bromide-iodide waters help create pleasurable and healthful relaxation.

Effect: relief of rheumatism, arthritis and neuritis symptoms

and post-trauma care.

Essential oils: cypress, grapefruit, thyme, geranium.

DES THERMES À DOMICILE.

L'idée de base: recréer le plus fidèlement possible

et de la manière la plus bénéfique qui soit, les propriétés

chimico-physiques des eaux thermales et leurs bienfaits dans

la baignoire du foyer. Les solutions salines contiennent des

éléments présents dans les eaux thermales et sont dotées

de propriétés bienfaitrices qui offrent des effets relaxants,

nourrissants et tonifiants. Les diverses combinaisons de ces

éléments produisent 6 mélanges différents, 6 catégories

d'eaux thermales, dotées chacune de ses propres

vertus et actions spécifiques. L'adjonction d'huiles

essentielles naturelles, à base végétale, amplifie les effets des

solutions salines, créant une synergie inédite en matière d'eau

thermale. Par exemple, l'huile essentielle de Camomille ou de

Lavande accentue les effets relaxants, celles de Menthe Poirrée

ou de Sauge conviennent parfaitement pour un bain tonifiant, et

celles de Géranium ou de Pamplemousse pour un bain défatigant.

**Programme 1: RELAXANT**

Les eaux saumâtres, riches en chlorure de sodium et en sulfates,

sont idéales pour une relaxation bienfaitrice et offrent

d'agréables sensations anti-stress.

Effets: apaisant, reposant, décontractant.

Huiles essentielles contenues: Orange douce, Lavande, Mélisse, Ylang-ylang.

**Programme 2: RÉÉQUILIBRANT**

Les eaux saumâtres, lithinées, riches en oligo-éléments,

aident à retrouver l'équilibre naturel et offrent un effet lénifiant et calmant.

Effets: apaisant, anti-inflammatoire.

Huiles essentielles contenues: Orange douce, Lavande, Mélisse, Ylang-ylang.

**Programme 3: TONIFIANT**

Les eaux bromo-iodiques, riches en oligo-éléments,

sont une source d'énergie naturelle et vitale pour le corps et l'esprit.

Effets: tonique, remontant, énergisant, réactivant.

Huiles essentielles contenues: Thym, Sauge, Romarin, Menthe.

**Programme 4: STIMULANT**

Les eaux saumâtres, bromo-iodiques,

s'avèrent d'une aide précieuse

pour améliorer et réactiver la circulation.

Effets : régénérant, remodelant.

Huiles essentielles contenues: Thym, Sauge, Romarin, Menthe.

**Programme 5: DÉFATIGANT**

Les eaux saumâtres et riches en bicarbonates sont idéales

pour les sportifs ou après une activité physique intense.

Effets: analgésique, antidouleur, aide à la résorption des oedèmes.

Huiles essentielles contenues: Cyprès, Pamplemousse, Thym, Géranium.

**Programme 6: APAISANT**

Les eaux bromo-iodiques permettent d'accéder à une agréable et bienfaitrice relaxation.

Effets: anti-rhumatismal, anti-arthritique, anti-néphrétique, post-traumatique.

Huiles essentielles contenues: Cyprès, Pamplemousse, Thym, Géranium.

LAS TERMAS EN TU PROPIA CASA.

La idea principal: recrear del modo más fiel y beneficioso

posible las características fisicoquímicas de las aguas

termales y de sus beneficios en la bañera de casa.

Las soluciones salinas contienen los elementos presentes

en las aguas termales, ricas en propiedades benéficas

con efectos relajantes, nutritivos y activadores.

Las diversas combinaciones de estos elementos dan origen

a seis mezclas, seis tipos distintos de aguas termales,

cada una con sus virtudes y acciones específicas.

La adición de aceites esenciales naturales de base vegetal exalta

los efectos de las soluciones salinas y crea una sinergia

que no se encuentra en ninguna agua termal. Por ejemplo,

el aceite esencial de camomila o de lavanda para acentuar

los efectos relajantes, el de menta piperita o de salvia para

un baño tonificante, el de geranio o el de pomelo

para gozar de un baño antifatiga.

**Programa 1: RELAJANTE**

Las aguas salinas, cloruro-sódicas o sulfatadas son ideales

para un relax benéfico, con agradable sensación antiestrés.

Efecto: distensivo, relajante, descontracturante.

Aceites esenciales que contiene: naranja dulce, lavanda, melisa, ylang-ylang.

**Programa 2: REEQUILIBRANTE**

Las aguas salinas, líticas con microelementos ayudan

a reencontrar el equilibrio natural, con un efecto lenitivo y calmante.

Efecto: mitigante, antiinflamatorio.

Aceites esenciales que contiene: naranja dulce,

lavanda, melisa, ylang-ylang.

**Programa 3: TONIFICANTE**

Las aguas bromo-yódicas con microelementos

son una fuente de energía natural y vital para el cuerpo y para la mente.

Efecto: tonificante, recargante, energizante, reactivador.

Aceites esenciales que contiene: tomillo, salvia, romero, menta.

**Programa 4: ESTIMULANTE**

Las aguas salinas bromo-yódicas se presentan como

una ayuda fundamental para mejorar y reactivar la circulación.

Efecto: regenerador, remodelador.

Aceites esenciales que contiene: tomillo, salvia, romero, menta.

**Programa 5: ANTIFATIGA**

Las aguas salinas y bicarbonatadas son ideales

para los deportistas o tras una actividad física intensa.

Efecto: analgésico, antidolorífico, facilitación

de la reabsorción edematosa. Aceites esenciales

que contiene: ciprés, pomelo, tomillo, geranio.

**Programa 6: DISTENSIVO**

Las aguas bromo-yódicas ayudan a crear un agradable y benéfico relax.

Efecto: antirreumático, antiartrítico, antineurítico, posttraumático.

Aceites esenciales que contiene: ciprés, pomelo, tomillo, geranio.

treesse

SPA



**CAMPO MAGNETICO BENEFICO ALL'INTERNO DELLA VASCA**

Il campo magnetico benefico viene creato solo all'interno della vasca con magneti permanenti posti alla base di essa, espressamente calcolato per magnetizzare la massa d'acqua.

**A HEALTHFUL MAGNETIC FIELD INSIDE THE BATHTUB**

A healthful magnetic field is created inside the bathtub with permanent magnets on the tub's bottom, carefully calibrated to magnetize the water mass.

**LES BIENFAITS D'UN CHAMP MAGNÉTIQUE DANS LA BAIGNOIRE**

Les bienfaits du champ magnétique, créé exclusivement à l'intérieur de la baignoire, sont dus à des aimants permanents, placés à l'intérieur de cette dernière, et spécialement conçus pour magnétiser la masse d'eau.

**CAMPO MAGNÉTICO BENÉFICO EN EL INTERIOR DE LA BAÑERA**

El campo magnético benéfico se crea sólo en el interior de la bañera con imanes permanentes colocados en su base, y está expresamente calculado para magnetizar la masa de agua.

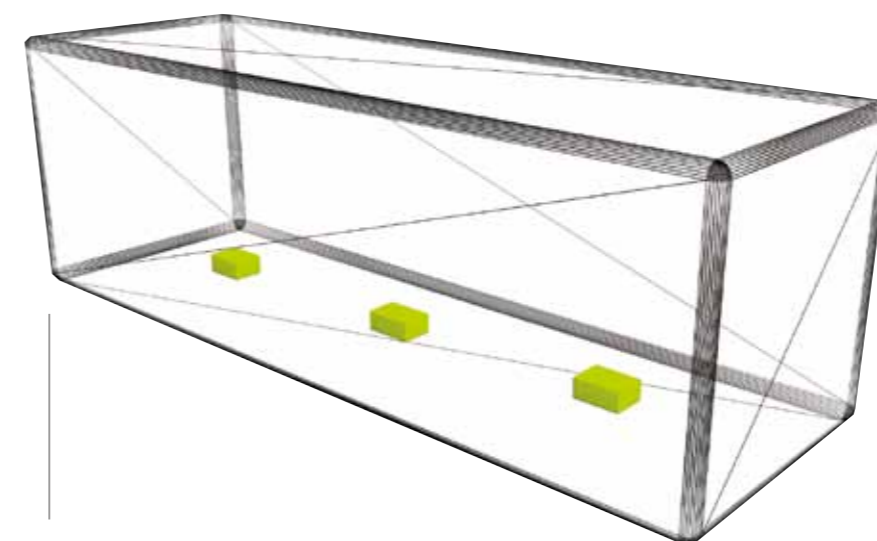

Posizionamento dei magneti all'interno della vasca.  
Positioning of magnets inside bathtub.  
Positionnement des aimants à l'intérieur de la baignoire.  
Colocación de los imanes en el interior de la bañera.

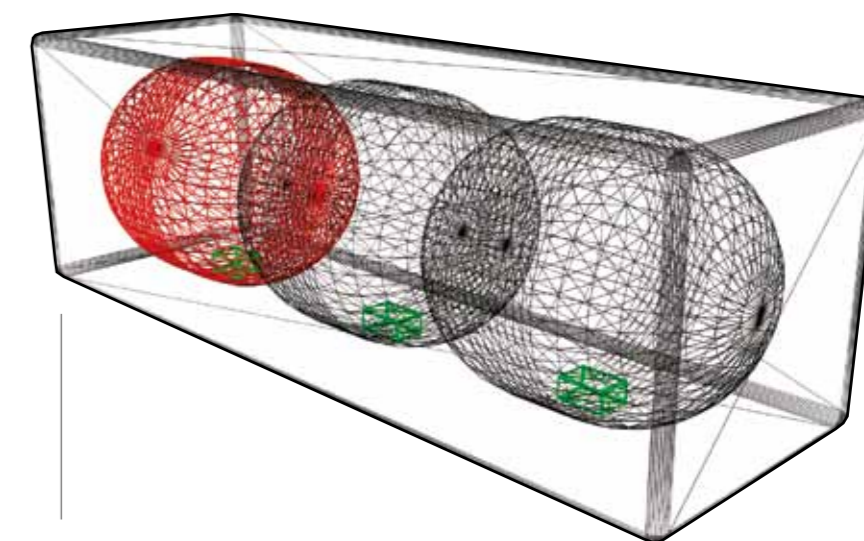

Campo magnetico della vasca.  
Bathtub's magnetic field.  
Champ magnétique de la baignoire.  
Campo magnético de la bañera.

#### L'ACQUA MAGNETIZZATA:

##### UN'ATTRAZIONE IRRESISTIBILE PER IL BENESSERE.

Il principio su cui funziona il sistema è quello dell'acqua magnetizzata.

Due poli inseriti nella vasca creano un campo magnetico

che potenzia gli elementi termali attivi presenti nei sali, esaltandone le proprietà.

Il risultato è un flusso di energia benefica che si diffonde nell'acqua e nel corpo, permettendo all'organismo di assimilare al meglio i benefici dei sali minerali e delle essenze, aiutandolo a eliminare le tossine in eccesso che causano problemi dermatologici, tonificando la pelle, rendendola più morbida ed elastica.

Il beneficio si estende anche ad aspetti psicologici fondamentali, creando un relax totale che permette di alleviare le tensioni muscolari dovute allo stress.

Vere e benefiche coccole per l'anima e il corpo.

##### BENEFICI PER TUTTI.

Nella vasca termale possono immergersi tutti, comprese le donne in gravidanza e i bambini. Solo l'acqua magnetizzata è sconsigliata

a chi utilizza impianti medicali di tipo elettrico, come pacemaker e microchip.

#### L'EAU MAGNÉTISÉE :

##### UNE IRRÉSISTIBLE ATTRACTION VERS LE BIEN-ÊTRE.

Ce système se base sur le principe de l'eau magnétisée. Deux pôles intégrés à la baignoire génèrent un champ magnétique qui accroît la puissance des éléments thermaux actifs présents dans les sels, en renforçant les propriétés.

Cela se traduit par un flux d'énergie bienfaitrice qui se diffuse dans l'eau et dans le corps et permet à l'organisme de mieux assimiler les bienfaits des sels minéraux et des essences, tout en l'aidant à éliminer l'excès de toxines, responsables des problèmes dermatologiques, en tonifiant la peau, en l'adoucissant et en l'assouplissant.

Ces bienfaits s'étendent aussi aux aspects psychologiques fondamentaux et permettent d'accéder à une relaxation totale qui aide à soulager les tensions musculaires dues au stress.

De véritables caresses bienfaitrices pour l'esprit et pour le corps.

##### DES BIENFAITS POUR TOUTE LA FAMILLE.

Chacun peut s'immerger dans le bain thermal, y compris les femmes enceintes et les enfants. L'eau magnétisée n'est déconseillée qu'aux personnes porteuses d'appareils médicaux électriques, tels que les pacemakers et les micro-puces.

#### MAGNETIZED WATER:

##### AN IRRESISTIBLE DRAW FOR GOOD HEALTH.

Magnetized water is the principle on which the system works.

Two poles inserted in the bathtub form a magnetic field that boosts the effects of the active spa ingredients in the salts, enhancing their properties.

The result is a flow of healthy energy that spreads through the water and your body, helping it optimally absorb the benefits of the mineral salts and essences.

This helps eliminate the build-up of toxins that can create skin problems and it tones skin, making it softer and more elastic.

The benefit has important psychological effects too for total relaxation that alleviates muscle tensions caused by stress.

True pampering for your body and soul.

##### SUITABLE FOR USE BY EVERYONE.

Anyone can soak in the spa bathtub, including pregnant women and children.

The magnetized water is not advised only for those who use electric medical devices, such as pacemakers and microchips.

#### EL AGUA MAGNETIZADA:

##### UNA ATRACCIÓN IRRESISTIBLE HACIA EL BIENESTAR.

El principio por el que funciona el sistema es el del agua magnetizada.

Dos polos introducidos en la bañera crean un campo magnético que potencia los elementos termales activos presentes en las sales y magnifica sus propiedades.

El resultado es un flujo de energía benéfica que se difunde en el agua y en el cuerpo y permite al organismo asimilar al máximo los beneficios de las sales minerales y de las esencias y lo ayuda a eliminar las toxinas que causan problemas dermatológicos a la vez que tonifica la piel y la deja más suave y elástica.

El beneficio se extiende también a los aspectos psicológicos fundamentales y crea un relax total que permite aliviar las tensiones musculares producidas por el estrés.

Verdaderas y benéficas caricias para el cuerpo y para el espíritu.

##### BENEFICIOS PARA TODOS.

En la bañera termal se puede sumergir cualquiera, incluidas las embarazadas y los niños. Únicamente se desaconseja el uso de agua magnetizada para aquéllos que utilizan implantes médicos de tipo eléctrico, como marcapasos y microchips.





#### TRE MODI, TRE TEMPERATURE, PER TRE EFFETTI SPECIFICI

##### BAGNO FREDDO

Per il Programma Tonicante.  
Temperatura dell'acqua tra i 23 e i 26 gradi.  
> COME FARE

Immergersi in maniera progressiva:  
dapprima per pochissimi secondi (non più di venti)  
per arrivare a un massimo di dieci minuti.  
Prima e dopo il bagno è consigliabile svolgere  
dieci minuti di esercizi muscolari  
e delle spugnature con acqua fredda,  
in particolare sulla colonna vertebrale.

##### > QUANDO E OGNI QUANTO

Ideale alla mattina, due-tre volte la settimana.

##### > PER CHI, PERCHÈ

Per la sua efficacia tonificante ed energizzante,  
indicato a chi soffre di pressione bassa.

##### BAGNO NEUTRO

Per tutti i programmi.  
Temperatura dell'acqua tra i 36 e i 38 gradi.  
> COME FARE

Immergersi per venti minuti.

##### > QUANDO E OGNI QUANTO

Prima di andare a letto, anche ogni sera.

##### > PER CHI, PERCHÈ

E' un ottimo distensivo per i muscoli, e quindi è utile  
per i cardiopatici e gli ipotesici,  
per chi ha problemi renali, tendenza all'obesità.

##### BAGNO CALDO

Per i Programmi Rilassante e Defaticante.  
Temperatura dell'acqua tra i 40 e i 42 gradi.  
> COME FARE

Immergersi per quindici-venti minuti.

##### > QUANDO E OGNI QUANTO

Un paio di volte la settimana, al mattino o alla sera.

##### > PER CHI, PERCHÈ

E' indicato come rilassante per le persone  
particolarmente stressate, ed è utile anche in stato  
di convalescenza o affaticamento.

#### THREE MODES, THREE TEMPERATURES, FOR THREE TARGETED EFFECTS

##### COOL BATH

For the Invigorating Program.  
Water temperature between 23 and 26 degrees Celsius.  
> WHAT TO DO

Progressively increase your time in the bath:  
first for just a few seconds (no more than 20)  
then up to a maximum of ten minutes.  
Before and after the bath,  
try doing ten minutes of muscular exercises  
and sponge yourself in cool water,  
especially along your spinal column.

##### > WHEN AND HOW OFTEN

Perfect for mornings, two or three times a week.

##### > WHO AND WHY

For its Invigorating, Energizing programs  
suggested for people with low blood pressure.

##### NEUTRAL BATH

For all programs.  
Water temperature between 36 and 38 degrees Celsius.  
> WHAT TO DO

Soak for twenty minutes.

##### > WHEN AND HOW OFTEN

Before going to bed, every evening, if you like.

##### > WHO AND WHY

Excellent for relaxing muscles, making it useful  
for those with heart disease, hypotension,  
kidney problems or who tend towards obesity.

##### HOT BATH

For the Relaxing and Fatigue-relieving programs.  
Water temperature between  
40 and 42 degrees Celsius.

##### > WHAT TO DO

Soak for fifteen to twenty minutes.

##### > WHEN AND HOW OFTEN

A few times a week, in the morning or evening.

##### > WHO AND WHY

Suggested for relaxation for highly stressed people.  
It is also useful when convalescing or fatigued.

## TROIS MODES, TROIS TEMPÉRATURES, POUR TROIS EFFETS SPÉCIFIQUES

### BAIN FROID

Programme Tonifiant.

Température de l'eau comprise entre 23 et 26°.

> COMMENT PROCÉDER ?

S'immerger de manière progressive: au début, quelques secondes seulement (pas plus de vingt) pour parvenir à un maximum de dix minutes.

Il est recommandé, avant et après le bain, de pratiquer des exercices musculaires pendant une dizaine de minutes et d'effectuer des ablutions à l'eau froide, en particulier sur la colonne vertébrale.

> QUAND ET À QUEL RYTHME ?

Idéal le matin, deux à trois fois par semaine.

> POUR QUI ? POUR QUOI ?

Ses bienfaits tonifiants et énergisants sont indiqués aux personnes souffrant d'une tension basse.

### BAIN NEUTRE

Tous programmes.

Température de l'eau comprise entre 36 et 38°.

> COMMENT PROCÉDER ?

S'immerger durant vingt minutes.

> QUAND ET À QUEL RYTHME ?

Avant d'aller se coucher, tous les soirs.

> POUR QUI ? POUR QUOI ?

Excellent pour détendre les muscles, il convient aux sujets cardiaques et hypotendus, aux personnes ayant des problèmes rénaux ou une tendance à l'obésité.

### BAIN CHAUD

Programmes Relaxant et Défatigant

Température de l'eau comprise entre 40 et 42°.

> COMMENT PROCÉDER ?

S'immerger durant quinze à vingt minutes.

> QUAND ET À QUEL RYTHME ?

Deux fois par semaine, le matin ou le soir.

> POUR QUI ? POUR QUOI ?

Indiqué pour relaxer les individus particulièrement stressés, convient également aux états de convalescence ou de fatigue.

## TRES MODOS, TRES TEMPERATURAS, PARA TRES EFECTOS ESPECÍFICOS

### BAÑO FRÍO

Para el programa tonificante

Temperatura del agua entre 23 y 26 grados.

> MODO DE USO

Sumérgete de forma progresiva:

al principio poquísimos segundos (no más de veinte) para llegar a un máximo de diez minutos.

Antes y después del baño es aconsejable realizar diez minutos de ejercicios musculares y pases de esponja con agua fría, en concreto sobre la columna vertebral.

> CUÁNDO Y CON QUÉ FRECUENCIA

Ideal por la mañana, dos o tres veces a la semana.

> PARA QUIÉN, PARA QUÉ

Por su eficacia tonificante y energética está indicado para personas con la tensión baja.

### BAÑO NEUTRO

Para todos los programas

Temperatura del agua, entre 36 y 38 grados.

> MODO DE USO

Sumérgete durante veinte minutos.

> CUÁNDO Y CON QUÉ FRECUENCIA

Antes de irse a dormir,

si se desea todas las noches.

> PARA QUIÉN, PARA QUÉ

Es un óptimo distensivo para los músculos y, por tanto, resulta útil para los pacientes cardíacos y los hipotensos, para quienes sufren problemas renales y tendencia a la obesidad.

### BAÑO CALIENTE

Para los programas relajante y antifatiga

Temperatura del agua entre los 40 y los 42 grados.

> MODO DE USO

Sumérgete durante quince o veinte minutos.

> CUÁNDO Y CON QUÉ FRECUENCIA

Un par de veces a la semana, por la mañana o por la tarde.

> PARA QUIÉN, PARA QUÉ

Está indicado como relajante para las personas especialmente estresadas y resulta útil también en estados de convalecencia o fatiga.



### IL RELAX NASCE DALLA SEMPLICITÀ.

Un tasto, e nella tua vasca puoi goderti il piacere di un vero bagno termale.

Scegli con il telecomando il programma; entra nella vasca e goditi il relax.

Il telecomando concentra tutte le funzioni; tutto sempre comodamente a portata di mano.

### RELAXATION COMES FROM SIMPLICITY.

At the touch of a button, you can enjoy the pleasure of a spa treatment in your bathtub.

Use the remote control to choose the program you want, get into your tub and start relaxing.

The remote control covers all functions, all conveniently within easy reach.

### LA RELAXATION NAÎT DE LA SIMPLICITÉ.

À partir d'une simple touche, savourez dans votre baignoire le plaisir d'un vrai bain thermal.

Choisissez votre programme à l'aide de la télécommande; immergez-vous dans la baignoire et profitez des bienfaits de la relaxation. Toujours à portée de main, la télécommande vous donne aisément accès à toutes les fonctions.

### EL RELAX NACE DE LA SENCILLEZ.

Un botón, y en tu bañera podrás disfrutar del placer de un verdadero baño termal.

Elige con el mando a distancia el programa, entra en la bañera y disfruta del relax.

El mando a distancia concentra todas las funciones; todo siempre cómodamente al alcance de la mano.

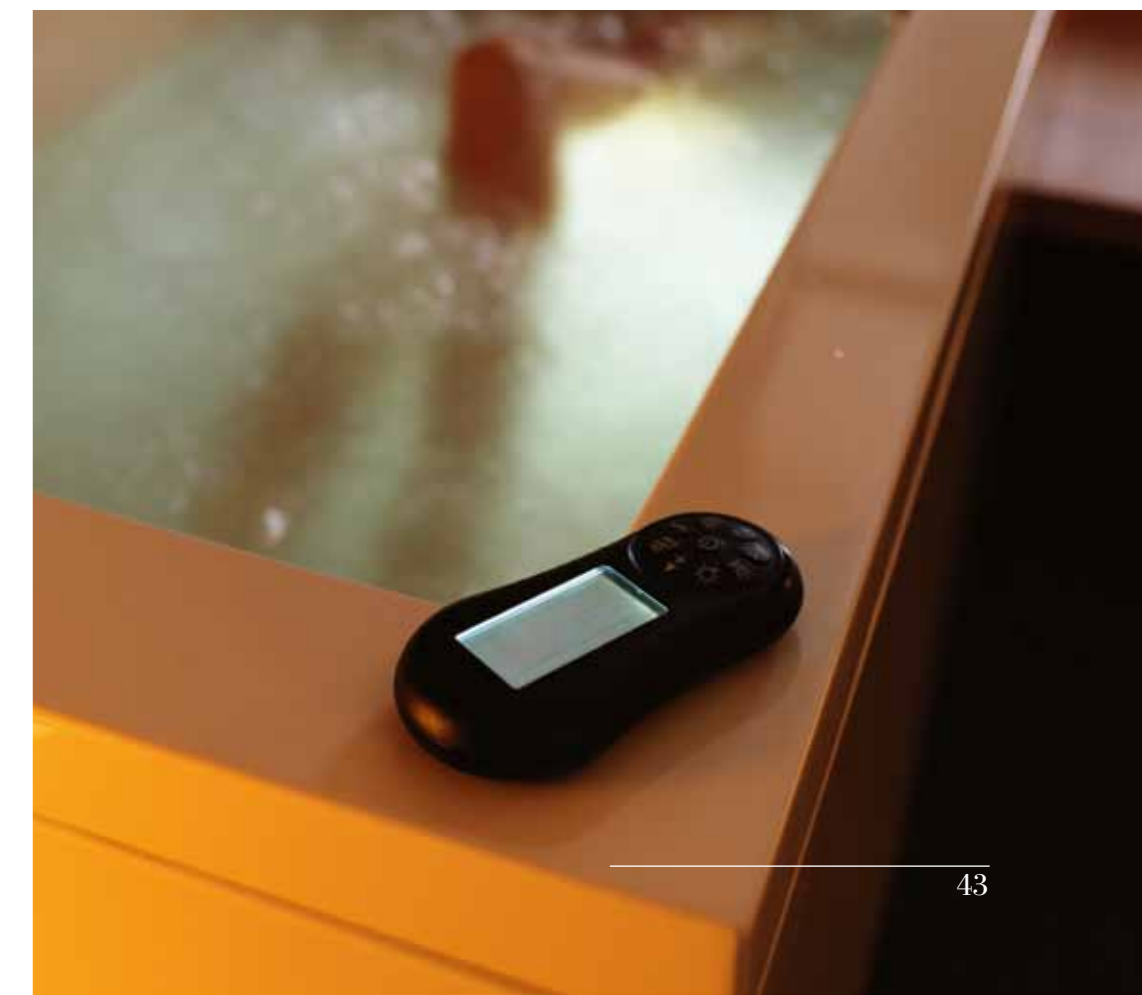



Il Gruppo Treesse crea i nuovi scenari dove rivivere il legame tra acqua e uomo, spazi che liberano emozioni positive e soddisfano le esigenze contemporanee. Design originale e prestazioni tecnologiche assicurano benessere: un mondo meraviglioso dove entrare, dove il relax ora è davvero qualcosa di personale.

The Gruppo Treesse creates new worlds that revive the link between people and water in spaces that invite positive emotions and meet contemporary needs. Original design and technological performances ensure wellbeing. Come into an extraordinary world where relaxation has become truly personal.

Le Gruppo Treesse conçoit de nouveaux environnements qui permettent de recréer un lien entre l'eau et les hommes, des espaces qui dégagent des émotions positives tout en répondant à des exigences contemporaines. Son design original associé à ses prestations technologiques assurent le bien-être. L'accès à un monde merveilleux où la relaxation se fait désormais plus personnelle.

El Gruppo Treesse crea los nuevos escenarios en los que revivir el vínculo entre agua y hombre, espacios que liberan emociones positivas y satisfacen las exigencias actuales. Diseño original y prestaciones tecnológicas que aseguran el bienestar: un mundo maravilloso en el que entrar, donde el relax es verdaderamente algo personal.

# HOME



*Bis*

190 X 150 X 65h.

*Bis line*

190 X 150 X 65h.

*Bis one top*

218 X 166/187 X 65h.

*Bis one steel*

202 X 150 X 65h.

*Inside*

190 X 235 X 70h.

*Matrix slim*

170 X 138 X 75h.

*Matrix midi*

170 X 138 X 220h.

*Matrix top*

170 X 138 X 215h.

*Ninfa*

185 X 185 X 63h.

*Perla*

182 X 182 X 63h.



*Bis*

190 X 150 X 65h.



tresse

HOME

GRANDI VASCHE  
LARGE BATHUBS





# Bis line

designer Paolo Parea

190 X 150 X 65h.

tresse

HOME

GRANDI VASCHE  
LARGE BATHUBS



Bis line

53

# Bis one top

designer Paolo Parea

218 X 166/187 X 65h.



tresse

HOME

GRANDI VASCHE  
LARGE BATHUBS

Bis one top  
55



# Bis one steel

designer Paolo Parea

202 X 150 X 65h.



treesse

HOME

GRANDI VASCHE  
LARGE BATHUBS

Bis one steel

57



# Bis

190 X 150 X 65h.

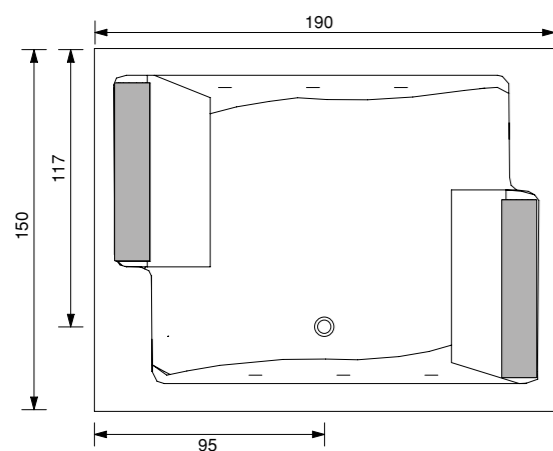
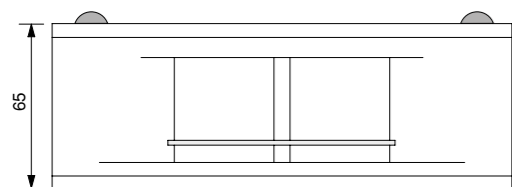

#### DOTAZIONI E OPTIONAL

- DOPPIA SEDUTA INTERNA
- POGGIATESTA RIALZATI CON CUSCINO
- MANIGLIE DI SOSTEGNO
- IDROMASSAGGIO
- AIRPOOL
- SENSORE DI LIVELLO
- IMPIANTO DI DISINFEZIONE
- STABILIZZATORE TEMPERATURA ACQUA
- CROMOTERAPIA
- FARO
- RADIO
- INGRESSO AUDIO PER IPOD/CD
- OZONO TERAPIA
- RUBINETTERIA BORDO VASCA
- TELECOMANDO PER CONTROLLO FUNZIONI

#### FOURNITURES ET OPTIONS

- DOUBLE ASSISE INTERNE
- REPOSE-TETE REHAUSSES AVEC COUSSIN
- POIGNEES DE SOUTIEN
- HYDROMASSAGE
- AIRPOOL
- CAPTEUR DE NIVEAU
- INSTALLATION DE DESINFECTION
- STABILISATEUR TEMPERATURE DE L'EAU
- CHROMOTHERAPIE
- SPOT
- RADIO
- ENTREE AUDIO POUR IPOD/CD
- OZONOTHERAPIE
- ROBINETTERIE REBORD DE BAIGNOIRE
- TELECOMMANDE POUR CONTROLE DES FONCTIONS

#### FEATURES AND OPTIONALS

- INTERNAL TWIN SEATS
- RAISED HEADRESTS WITH CUSHION
- GRAB BARS
- HYDROMASSAGE
- AIRPOOL
- LEVEL SENSOR
- DISINFECTION SYSTEM
- WATER TEMPERATURE STABILIZER
- COLOR THERAPY
- SPOTLIGHT
- RADIO
- AUDIO INPUT FOR IPOD/CD
- OZONE THERAPY
- TUB EDGE FAUCETS
- REMOTE CONTROL FOR FUNCTIONS

#### CARACTERÍSTICAS Y COMPLEMENTOS

- DOBLE ASIENTO INTERIOR
- REPOSACABEZAS ELEVADOS CON COJÍN
- ASIDEROS DE APOYO
- HIDROMASAJE
- AIRPOOL
- SENSOR DE NIVEL
- SISTEMA DE DESINFECCIÓN
- ESTABILIZADOR DE LA TEMPERATURA DEL AGUA
- CROMOTERAPIA
- LUZ
- RADIO
- ENTRADA DE AUDIO PARA IPOD/CD
- OZONOTERAPIA
- GRIFERÍA EN EL BORDE DE LA BAÑERA
- MANDO A DISTANCIA PARA CONTROL DE LAS FUNCIONES



# Bis line

190 X 150 X 65h.

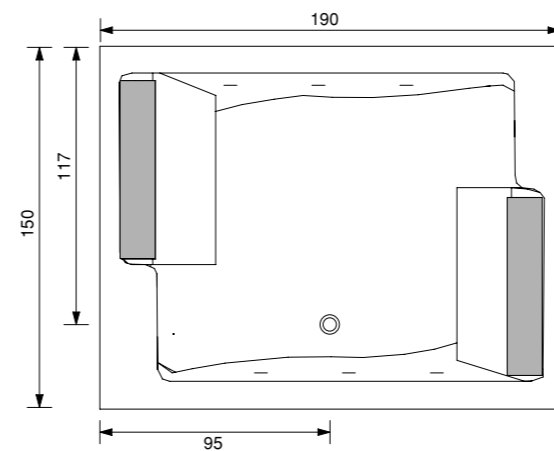
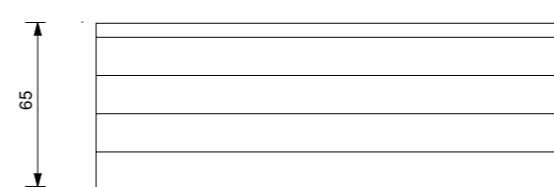

#### DOTAZIONI E OPTIONAL

- DOPPIA SEDUTA INTERNA
- POGGIATESTA RIALZATI CON CUSCINO
- MANIGLIE DI SOSTEGNO
- PANNELLO ESTERNO CON FINITURE IN ACCIAIO LUCIDO/ORO
- IDROMASSAGGIO
- AIRPOOL
- SENSORE DI LIVELLO
- IMPIANTO DI DISINFEZIONE
- STABILIZZATORE TEMPERATURA ACQUA
- CROMOTERAPIA
- FARO
- RADIO
- INGRESSO AUDIO PER IPOD/CD
- OZONO TERAPIA
- RUBINETTERIA BORDO VASCA
- TELECOMANDO PER CONTROLLO FUNZIONI

#### FOURNITURES ET OPTIONS

- DOUBLE ASSISE INTERNE
- REPOSE-TETE REHAUSSES AVEC COUSSIN
- POIGNEES DE SOUTIEN
- PANNEAU EXTERNE AVEC FINITIONS EN ACIER POLI/OR
- HYDROMASSAGE
- AIRPOOL
- CAPTEUR DE NIVEAU
- INSTALLATION DE DESINFECTION
- STABILISATEUR TEMPERATURE DE L'EAU
- CHROMOTHERAPIE
- SPOT
- RADIO
- ENTREE AUDIO POUR IPOD/CD
- OZONOTHERAPIE
- ROBINETTERIE REBORD DE BAIGNOIRE
- TELECOMMANDE POUR CONTROLE DES FONCTIONS

#### FEATURES AND OPTIONALS

- INTERNAL TWIN SEATS
- RAISED HEADRESTS WITH CUSHION
- GRAB BARS
- OUTER PANEL WITH GLOSSY STEEL/GOLD FINISHES
- HYDROMASSAGE
- AIRPOOL
- LEVEL SENSOR
- DISINFECTION SYSTEM
- WATER TEMPERATURE STABILIZER
- COLOR THERAPY
- SPOTLIGHT
- RADIO
- AUDIO INPUT FOR IPOD/CD
- OZONE THERAPY
- TUB EDGE FAUCETS
- REMOTE CONTROL FOR FUNCTIONS

#### CARACTERÍSTICAS Y COMPLEMENTOS

- DOBLE ASIENTO INTERIOR
- REPOSACABEZAS ELEVADOS CON COJÍN
- ASIDEROS DE APOYO
- PANEL EXTERIOR CON ACABADOS DE ACERO BRILLANTE/ORO
- HIDROMASAJE
- AIRPOOL
- SENSOR DE NIVEL
- SISTEMA DE DESINFECCIÓN
- ESTABILIZADOR DE LA TEMPERATURA DEL AGUA
- CROMOTERAPIA
- LUZ
- RADIO
- ENTRADA DE AUDIO PARA IPOD/CD
- OZONOTERAPIA
- GRIFERÍA EN EL BORDE DE LA BAÑERA
- MANDO A DISTANCIA PARA CONTROL DE LAS FUNCIONES



## Bis one top

218 X 166/187 X 65h.

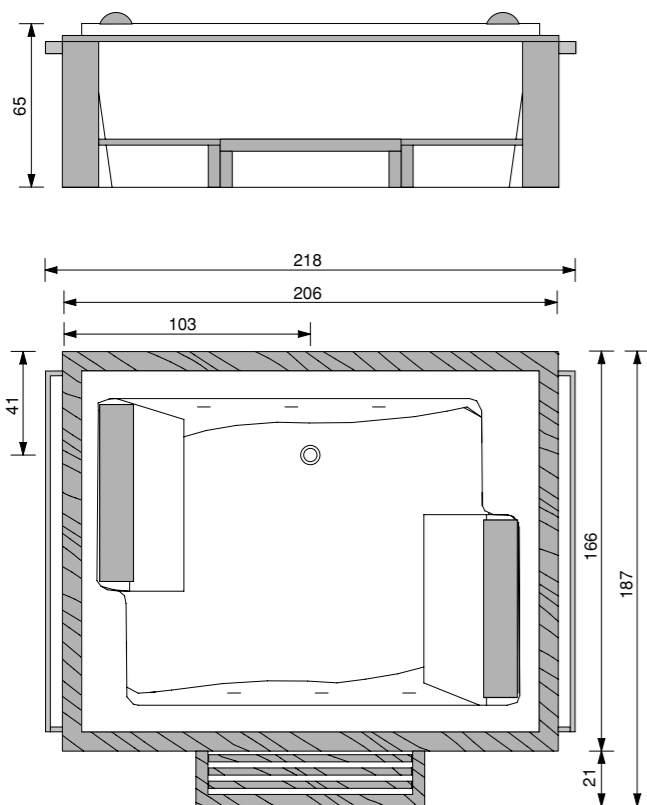

### DOTAZIONI E OPTIONAL

- STRUTTURA IN LEGNO MASSELLO
- GRADINO A SCOMPARSA
- PORTA ASCIUGAMANI
- DOPPIA SEDUTA INTERNA
- POGGIATESTA RIALZATI CON CUSCINO
- MANIGLIE DI SOSTEGNO
- IDROMASSAGGIO
- AIRPOOL
- SENSORE DI LIVELLO
- IMPIANTO DI DISINFEZIONE
- STABILIZZATORE TEMPERATURA ACQUA
- CROMOTERAPIA
- FARO
- RADIO
- INGRESSO AUDIO PER IPOD/CD
- OZONO TERAPIA
- RUBINETTERIA BORDO VASCA
- TELECOMANDO PER CONTROLLO FUNZIONI

### FOURNITURES ET OPTIONS

- STRUCTURE EN BOIS MASSIF
- MARCHE ESCAMOTABLE
- PORTE-SERVIETTES
- DOUBLE ASSISE INTERNE
- REPOSE-TETE REHAUSSES AVEC COUSSIN
- POIGNEES DE SOUTIEN
- HYDROMASSAGE
- AIRPOOL
- CAPTEUR DE NIVEAU
- INSTALLATION DE DESINFECTION
- STABILISATEUR TEMPERATURE DE L'EAU
- CHROMOTHERAPIE
- SPOT
- RADIO
- ENTREE AUDIO POUR IPOD/CD
- OZONOTHERAPIE
- RUBINETTERIE REBORD DE BAIGNOIRE
- TELECOMMANDE POUR CONTROLE DES FONCTIONS

### FEATURES AND OPTIONALS

- SOLID WOOD STRUCTURE
- PULL-OUT STEP
- TOWEL RACK
- INTERNAL TWIN SEATS
- RAISED HEADRESTS WITH CUSHION
- GRAB BARS
- HYDROMASSAGE
- AIRPOOL
- LEVEL SENSOR
- DISINFECTION SYSTEM
- WATER TEMPERATURE STABILIZER
- COLOR THERAPY
- SPOTLIGHT
- RADIO
- AUDIO INPUT FOR IPOD/CD
- OZONE THERAPY
- TUB EDGE FAUCETS
- REMOTE CONTROL FOR FUNCTIONS

### CARACTERÍSTICAS Y COMPLEMENTOS

- ESTRUCTURA DE MADERA MACIZA
- ESCALÓN RETRÁCTIL
- TOALLERO
- DOBLE ASIENTO INTERIOR
- REPOSACABEZAS ELEVADOS CON COJÍN
- ASIDEROS DE APOYO
- HIDROMASAJE
- AIRPOOL
- SENSOR DE NIVEL
- SISTEMA DE DESINFECCIÓN
- ESTABILIZADOR DE LA TEMPERATURA DEL AGUA
- CROMOTERAPIA
- LUZ
- RADIO
- ENTRADA DE AUDIO PARA IPOD/CD
- OZONOTERAPIA
- GRIFERÍA EN EL BORDE DE LA BAÑERA
- MANDO A DISTANCIA PARA CONTROL DE LAS FUNCIONES



## Bis one steel

202 X 150 X 65h.

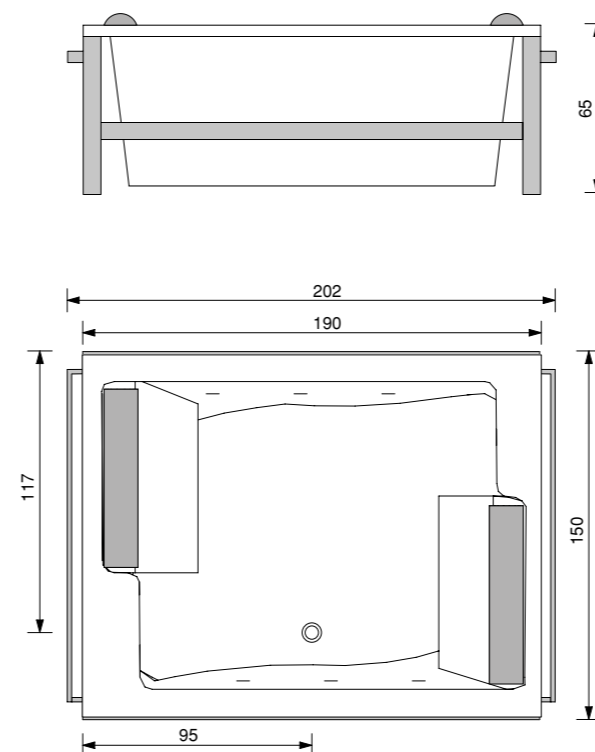

### DOTAZIONI E OPTIONAL

- STRUTTURA IN ACCIAIO BILUCIDO
- PORTA ASCIUGAMANI
- DOPPIA SEDUTA INTERNA
- POGGIATESTA RIALZATI CON CUSCINO
- MANIGLIE DI SOSTEGNO
- IDROMASSAGGIO
- AIRPOOL
- SENSORE DI LIVELLO
- IMPIANTO DI DISINFEZIONE
- STABILIZZATORE TEMPERATURA ACQUA
- CROMOTERAPIA
- FARO
- RADIO
- INGRESSO AUDIO PER IPOD/CD
- OZONO TERAPIA
- RUBINETTERIA BORDO VASCA
- TELECOMANDO PER CONTROLLO FUNZIONI

### FOURNITURES ET OPTIONS

- STRUCTURE EN ACIER POLI DES DEUX COTES
- PORTE-SERVIETTES
- DOUBLE ASSISE INTERNE
- REPOSE-TETE REHAUSSES AVEC COUSSIN
- POIGNEES DE SOUTIEN
- HYDROMASSAGE
- AIRPOOL
- CAPTEUR DE NIVEAU
- INSTALLATION DE DESINFECTION
- STABILISATEUR TEMPERATURE DE L'EAU
- CHROMOTHERAPIE
- SPOT
- RADIO
- ENTREE AUDIO POUR IPOD/CD
- OZONOTHERAPIE
- RUBINETTERIE REBORD DE BAIGNOIRE
- TELECOMMANDE POUR CONTROLE DES FONCTIONS

### FEATURES AND OPTIONALS

- DOUBLE-POLISHED STEEL STRUCTURE
- TOWEL RACK
- INTERNAL TWIN SEATS
- RAISED HEADRESTS WITH CUSHION
- GRAB BARS
- HYDROMASSAGE
- AIRPOOL
- LEVEL SENSOR
- DISINFECTION SYSTEM
- WATER TEMPERATURE STABILIZER
- COLOR THERAPY
- SPOTLIGHT
- RADIO
- AUDIO INPUT FOR IPOD/CD
- OZONE THERAPY
- TUB EDGE FAUCETS
- REMOTE CONTROL FOR FUNCTIONS

### CARACTERÍSTICAS Y COMPLEMENTOS

- ESTRUCTURA DE ACERO BRILLANTE POR AMBAS CARAS
- TOALLERO
- DOBLE ASIENTO INTERIOR
- REPOSACABEZAS ELEVADOS CON COJÍN
- ASIDEROS DE APOYO
- HIDROMASAJE
- AIRPOOL
- SENSOR DE NIVEL
- SISTEMA DE DESINFECCIÓN
- ESTABILIZADOR DE LA TEMPERATURA DEL AGUA
- CROMOTERAPIA
- LUZ
- RADIO
- ENTRADA DE AUDIO PARA IPOD/CD
- OZONOTERAPIA
- GRIFERÍA EN EL BORDE DE LA BAÑERA
- MANDO A DISTANCIA PARA CONTROL DE LAS FUNCIONES



*Inside*

designer Fabrizio Batoni

190 X 235 X 70h.



tresse

HOME

GRANDI VASCHE  
LARGE BATHUBS

*Inside*  
63





## Inside

190 X 235 X 70h.

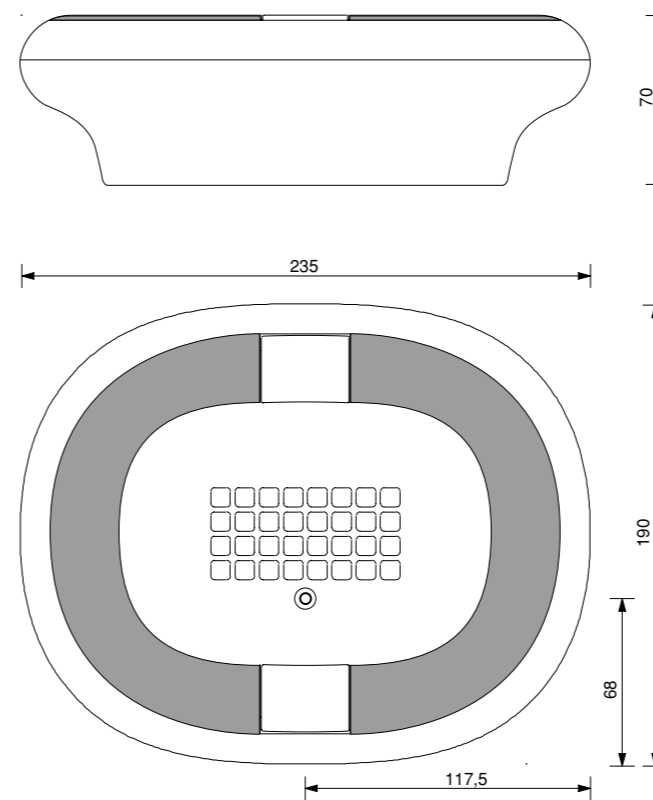

### DOTAZIONI E OPTIONAL

- DOPPIA SEDUTA INTERNA
- CUSCINI INTEGRATI - COLORE NERO
- BOCCA A VELA GRANDE AD INCASSO
- IDROMASSAGGIO
- AIRPOOL
- SENSORE DI LIVELLO
- IMPIANTO DI DISINFEZIONE
- STABILIZZATORE TEMPERATURA ACQUA
- CROMOTERAPIA
- FARO
- RADIO
- INGRESSO AUDIO PER IPOD/CD
- OZONO TERAPIA
- RUBINETTERIA BORDO VASCA
- TELECOMANDO PER CONTROLLO FUNZIONI

### FOURNITURES ET OPTIONS

- DOUBLE ASSISE INTERNE
- COUSSINS INTEGRÉS - COULEUR NOIRE
- GRANDE CHUTE D'EAU ENCASTRABLE
- HYDROMASSAGE
- AIRPOOL
- CAPTEUR DE NIVEAU
- INSTALLATION DE DESINFECTION
- STABILISATEUR TEMPERATURE DE L'EAU
- CHROMOTHERAPIE
- SPOT
- RADIO
- ENTREE AUDIO POUR IPOD/CD
- OZONOTHERAPIE
- ROBINETTERIE REBORD DE BAIGNOIRE
- TELECOMMANDE POUR CONTROLE DES FONCTIONS

### FEATURES AND OPTIONALS

- INTERNAL TWIN SEATS
- BLACK BUILT-IN CUSHIONS
- LARGE FLUSH-MOUNTED SHEETFLOW SPOUT
- HYDROMASSAGE
- AIRPOOL
- LEVEL SENSOR
- DISINFECTION SYSTEM
- WATER TEMPERATURE STABILIZER
- COLOR THERAPY
- SPOTLIGHT
- RADIO
- AUDIO INPUT FOR IPOD/CD
- OZONE THERAPY
- TUB EDGE FAUCETS
- REMOTE CONTROL FOR FUNCTIONS

### CARACTERÍSTICAS Y COMPLEMENTOS

- DOBLE ASIENTO INTERIOR
- COJINES INTEGRADOS - COLOR NEGRO
- CHORRO EN CORTINA GRANDE ENCASTRADO
- HIDROMASAJE
- AIRPOOL
- SENSOR DE NIVEL
- SISTEMA DE DESINFECCIÓN
- ESTABILIZADOR DE LA TEMPERATURA DEL AGUA
- CROMOTERAPIA
- LUZ
- RADIO
- ENTRADA DE AUDIO PARA IPOD/CD
- OZONOTERAPIA
- GRIFERÍA EN EL BORDE DE LA BAÑERA
- MANDO A DISTANCIA PARA CONTROL DE LAS FUNCIONES

# Matrix slim

designer Paolo Parea

170 X 138 X 75h.



Matrix slim  
69

Artesse

MODI  
GRANDI VASCHE  
LARGE BATHUBS



# Matrix midi

designer Paolo Parea

170 X 138 X 220h.



tresse

HOME

GRANDI VASCHE  
LARGE BATHUBS

Matrix midi  
73

# Matrix top

designer Paolo Parea

170 X 138 X 215h.



tresse

HOME

GRANDI VASCHE  
LARGE BATHUBS

Matrix top  
75



## Matrix slim

170 X 138 X 75h.

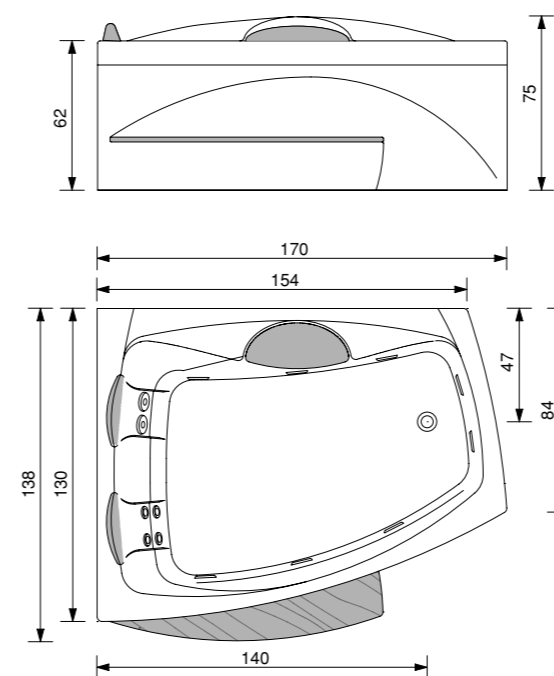

### DOTAZIONI E OPTIONAL

- DOPPIA SEDUTA INTERNA
- GRADINO PER ACCESSO FACILITATO
- CUSCINI POGGIATESTA
- SEDILE
- EROGAZIONE ACQUA CON CASCATA
- IDROMASSAGGIO
- AIRPOOL
- SENSORE DI LIVELLO
- IMPIANTO DI DISINFEZIONE
- STABILIZZATORE TEMPERATURA ACQUA
- CROMOTERAPIA
- FARO
- RADIO
- INGRESSO AUDIO PER IPOD/CD
- OZONO TERAPIA
- RUBINETTERIA BORDO VASCA
- TELECOMANDO PER CONTROLLO FUNZIONI

### FOURNITURES ET OPTIONS

- DOUBLE ASSISE INTERNE
- MARCHE POUR ACCES FACILITE
- COUSSINS REPOSE-TETE
- SIEGE
- DISTRIBUTION DE L'EAU EN CASCADE
- HYDROMASSAGE
- AIRPOOL
- CAPTEUR DE NIVEAU
- INSTALLATION DE DESINFECTION
- STABILISATEUR TEMPERATURE DE L'EAU
- CHROMOTHERAPIE
- SPOT
- RADIO
- ENTREE AUDIO POUR IPOD/CD
- OZONOTHERAPIE
- ROBINETTERIE REBORD DE BAIGNOIRE
- TELECOMMANDE POUR CONTROLE DES FONCTIONS

### FEATURES AND OPTIONALS

- INTERNAL TWIN SEATS
- STEP FOR EASY ACCESS
- HEADREST CUSHIONS
- SEAT
- WATERFALL FLOW
- HYDROMASSAGE
- AIRPOOL
- LEVEL SENSOR
- DISINFECTION SYSTEM
- WATER TEMPERATURE STABILIZER
- COLOR THERAPY
- SPOTLIGHT
- RADIO
- AUDIO INPUT FOR IPOD/CD
- OZONE THERAPY
- TUB EDGE FAUCETS
- REMOTE CONTROL FOR FUNCTIONS

### CARACTERÍSTICAS Y COMPLEMENTOS

- DOBLE ASIENTO INTERIOR
- ESCALÓN PARA FACILITAR EL ACCESO
- COJINES REPOSACABEZAS
- ASIENTO
- SUMINISTRO DE AGUA A CASCADA
- HIDROMASAJE
- AIRPOOL
- SENSOR DE NIVEL
- SISTEMA DE DESINFECCIÓN
- ESTABILIZADOR DE LA TEMPERATURA DEL AGUA
- CROMOTERAPIA
- LUZ
- RADIO
- ENTRADA DE AUDIO PARA IPOD/CD
- OZONOTERAPIA
- GRIFERÍA EN EL BORDE DE LA BAÑERA
- MANDO A DISTANCIA PARA CONTROL DE LAS FUNCIONES





# Matrix midi

170 X 138 X 220h.

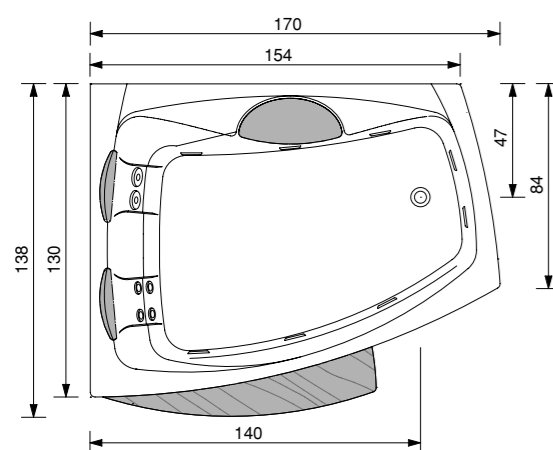
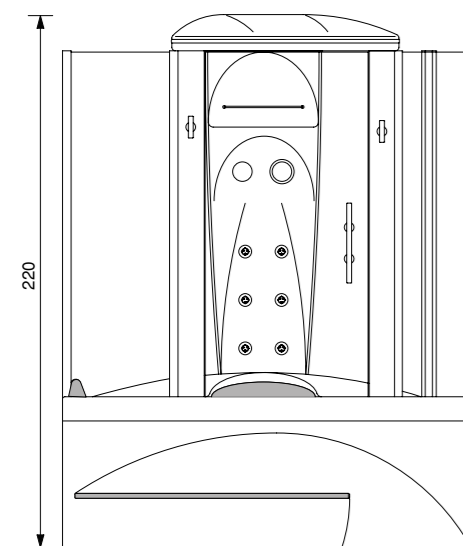

## DOTAZIONI E OPTIONAL

### VASCA:

- DOPPIA SEDUTA INTERNA
- GRADINO PER ACCESSO FACILITATO
- CUSCINI POGGIATESTA
- SEDILE
- EROGAZIONE ACQUA CON CASCATA
- IDROMASSAGGIO
- AIRPOOL
- SENSORE DI LIVELLO
- IMPIANTO DI DISINFEZIONE
- STABILIZZATORE TEMPERATURA ACQUA
- CROMOTERAPIA
- FARO
- RADIO
- INGRESSO AUDIO PER IPOD/CD
- OZONO TERAPIA
- RUBINETTERIA BORDO VASCA
- TELECOMANDO PER CONTROLLO FUNZIONI

### BOX:

- CRISTALLO TEMPERATO DA 6 MM
- TETTO MULTI FUNZIONE
- DOCCIONE
- NEBULIZZATORI INTEGRATI SUL TETTO
- CROMOTERAPIA
- FARO
- COLONNA SOPRAVASCA CON RUBINETTERIA
- JET MASSAGGIO VERTICALE
- JET MASSAGGIO DORSALE
- MENSOLE PORTA OGGETTI
- APPENDIABITI

## FEATURES AND OPTIONALS

### BATHTUB:

- INTERNAL TWIN SEATS
- STEP FOR EASY ACCESS
- HEADREST CUSHIONS
- SEAT
- WATERFALL FLOW
- HYDROMASSAGE
- AIRPOOL
- LEVEL SENSOR
- DISINFECTION SYSTEM
- WATER TEMPERATURE STABILIZER
- COLOR THERAPY
- SPOTLIGHT
- RADIO
- AUDIO INPUT FOR IPOD/CD
- OZONE THERAPY
- TUB EDGE FAUCETS
- REMOTE CONTROL FOR FUNCTIONS

### CUBICLE:

- TEMPERED GLASS, 6 MM
- MULTIPURPOSE ROOF
- SHOWER HEAD
- BUILT-IN MISTERS ON ROOF
- COLOR THERAPY
- SPOTLIGHT
- ABOVE-BATH COLUMN WITH FAUCETS
- VERTICAL MASSAGE JET
- BACK MASSAGE JET
- TOILETRY SHELVES
- HOOK

## FOURNITURES ET OPTIONS

### BAIGNOIRE:

- DOUBLE ASSISE INTERNE
- MARCHÉ POUR ACCES FACILITE
- COUSSINS REPOSE-TETE
- SIEGE
- DISTRIBUTION DE L'EAU EN CASCADE
- HYDROMASSAGE
- AIRPOOL
- CAPTEUR DE NIVEAU
- INSTALLATION DE DESINFECTION
- STABILISATEUR TEMPERATURE DE L'EAU
- CHROMOTHERAPIE
- SPOT
- RADIO
- ENTREE AUDIO POUR IPOD/CD
- OZONOTHERAPIE
- ROBINETTERIE REBORD DE BAIGNOIRE
- TELECOMMANDE POUR CONTROLE DES FONCTIONS

### CABINE:

- VERRE TREMPE DE 6 MM
- PLAFOND MULTIFONCTION
- POMME DE DOUCHE GRAND FORMAT
- NEBULISEURS INTEGRES AU PLAFOND
- CHROMOTHERAPIE
- SPOT
- COLONNE AU-DESSUS DE LA BAIGNOIRE AVEC ROBINETTERIE
- JET MASSAGE VERTICAL
- JET MASSAGE DORSAL
- ETAGERES PORTE-OBJETS
- PORTE-VETEMENTS

## CARACTERÍSTICAS Y COMPLEMENTOS

### BAÑERA:

- DOBLE ASIENTO INTERIOR
- ESCALÓN PARA FACILITAR EL ACCESO
- COJINES REPOSACABEZAS
- ASIENTO
- SUMINISTRO DE AGUA A CASCADA
- HIDROMASAJE
- AIRPOOL
- SENSOR DE NIVEL
- SISTEMA DE DESINFECCIÓN
- ESTABILIZADOR DE LA TEMPERATURA DEL AGUA
- CROMOTERAPIA
- LUZ
- RADIO
- ENTRADA DE AUDIO PARA IPOD/CD
- OZONOTERAPIA
- GRIFERÍA EN EL BORDE DE LA BAÑERA
- MANDO A DISTANCIA PARA CONTROL DE LAS FUNCIONES

### CABINA:

- CRISTAL TEMPLADO DE 6 MM
- TECHO MULTIFUNCIÓN
- ALCACHOFA CENTRAL
- NEBULIZADORES INTEGRADOS EN EL TECHO
- CROMOTERAPIA
- LUZ
- COLUMNA SOBRE LA BAÑERA CON GRIFERÍA
- CHORRO MASAJE VERTICAL
- CHORRO MASAJE DORSAL
- ESTANTES PORTAOBJETOS
- PERCHA



# Matrix top

170 X 138 X 215h.

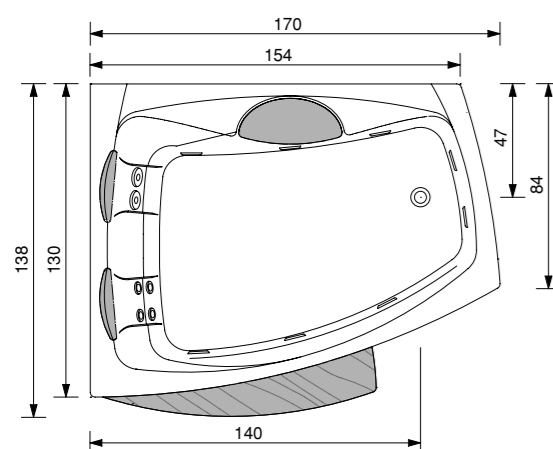
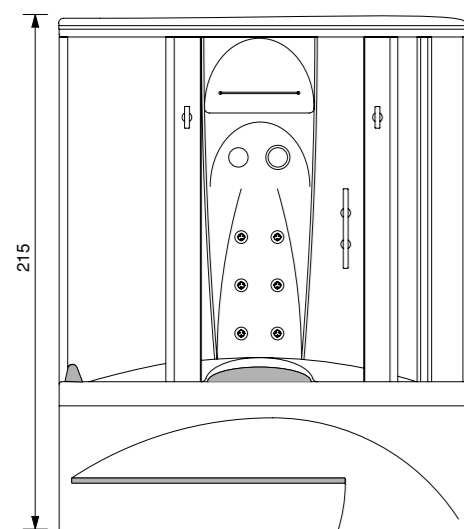

## DOTAZIONI E OPTIONAL

### VASCA:

- DOPPIA SEDUTA INTERNA
- GRADINO PER ACCESSO FACILITATO
- CUSCINI POGGIATESTA
- SEDILE
- EROGAZIONE ACQUA CON CASCATA
- IDROMASSAGGIO
- AIRPOOL
- SENSORE DI LIVELLO
- IMPIANTO DI DISINFEZIONE
- STABILIZZATORE TEMPERATURA ACQUA
- CROMOTERAPIA
- FARO
- RADIO
- INGRESSO AUDIO PER IPOD/CD
- OZONO TERAPIA
- RUBINETTERIA BORDO VASCA
- TELECOMANDO PER CONTROLLO FUNZIONI

### BOX:

- CRISTALLO TEMPERATO DA 6 MM
- BAGNO TURCO MONOCLIMA
- TETTO MULTI FUNZIONE
- DOCCIONE
- NEBULIZZATORI INTEGRATI SUL TETTO
- CROMOTERAPIA
- FARO
- COLONNA SOPRAVASCA CON RUBINETTERIA
- JET MASSAGGIO VERTICALE
- JET MASSAGGIO DORSALE
- MENSOLE PORTA OGGETTI
- APPENDIABITI

## FEATURES AND OPTIONALS

### BATHTUB:

- INTERNAL TWIN SEATS
- STEP FOR EASY ACCESS
- HEADREST CUSHIONS
- SEAT
- WATERFALL FLOW
- HYDROMASSAGE
- AIRPOOL
- LEVEL SENSOR
- DISINFECTION SYSTEM
- WATER TEMPERATURE STABILIZER
- COLOR THERAPY
- SPOTLIGHT
- RADIO
- AUDIO INPUT FOR IPOD/CD
- OZONE THERAPY
- TUB EDGE FAUCETS
- REMOTE CONTROL FOR FUNCTIONS

### CUBICLE:

- TEMPERED GLASS, 6 MM
- SINGLE-SETTING STEAM BATH
- MULTIPURPOSE ROOF
- SHOWER HEAD
- BUILT-IN MISTERS ON ROOF
- COLOR THERAPY
- SPOTLIGHT
- ABOVE-BATH COLUMN WITH FAUCETS
- VERTICAL MASSAGE JET
- BACK MASSAGE JET
- TOILETRY SHELVES
- HOOK

## FOURNITURES ET OPTIONS

### BAIGNOIRE:

- DOUBLE ASSISE INTERNE
- MARCHÉ POUR ACCÈS FACILITE
- COUSSINS REPOSE-TÊTE
- SIÈGE
- DISTRIBUTION DE L'EAU EN CASCADE
- HYDROMASSAGE
- AIRPOOL
- CAPTEUR DE NIVEAU
- INSTALLATION DE DESINFECTION
- STABILISATEUR TEMPERATURE DE L'EAU
- CHROMOTHERAPIE
- SPOT
- RADIO
- ENTREE AUDIO POUR IPOD/CD
- OZONOTHERAPIE
- ROBINETTERIE REBORD DE BAIGNOIRE
- TELECOMMANDE POUR CONTROL DES FONCTIONS

### CABINE:

- VERRE TREMPÉ DE 6 MM
- BAIN TURC MONO-CLIMAT
- PLAFOND MULTIFONCTION
- POMME DE DOUCHE GRAND FORMAT
- NEBULISEURS INTEGRES AU PLAFOND
- CHROMOTHERAPIE
- SPOT
- COLONNE AU-DESSUS DE LA BAIGNOIRE AVEC ROBINETTERIE
- JET MASSAGE VERTICAL
- JET MASSAGE DORSAL
- ETAGERES PORTE-OBJETS
- PORTE-VETEMENTS

## CARACTERÍSTICAS Y COMPLEMENTOS

### BAÑERA:

- DOBLE ASIENTO INTERIOR
- ESCALÓN PARA FACILITAR EL ACCESO
- COJINES REPOSACABEZAS
- ASIENTO
- SUMINISTRO DE AGUA A CASCADA
- HIDROMASAJE
- AIRPOOL
- SENSOR DE NIVEL
- SISTEMA DE DESINFECCIÓN
- ESTABILIZADOR DE LA TEMPERATURA DEL AGUA
- CROMOTERAPIA
- LUZ
- RADIO
- ENTRADA DE AUDIO PARA IPOD/CD
- OZONOTERAPIA
- GRIFERÍA EN EL BORDE DE LA BAÑERA
- MANDO A DISTANCIA PARA CONTROL DE LAS FUNCIONES

### CABINA:

- CRISTAL TEMPLADO DE 6 MM
- BAÑO TURCO MONOCLIMA
- TECHO MULTIFUNCIÓN
- ALCACHOFA CENTRAL
- NEBULIZADORES INTEGRADOS EN EL TECHO
- CROMOTERAPIA
- LUZ
- COLUMNA SOBRE LA BAÑERA CON GRIFERÍA
- CHORRO MASAJE VERTICAL
- CHORRO MASAJE DORSAL
- ESTANTES PORTAOBJETOS
- PERCHA

# Ninfa

185 X 185 X 63h.



tresse

HOME

GRANDI VASCHE  
LARGE BATHUBS



## Ninfa

185 X 185 X 63h.

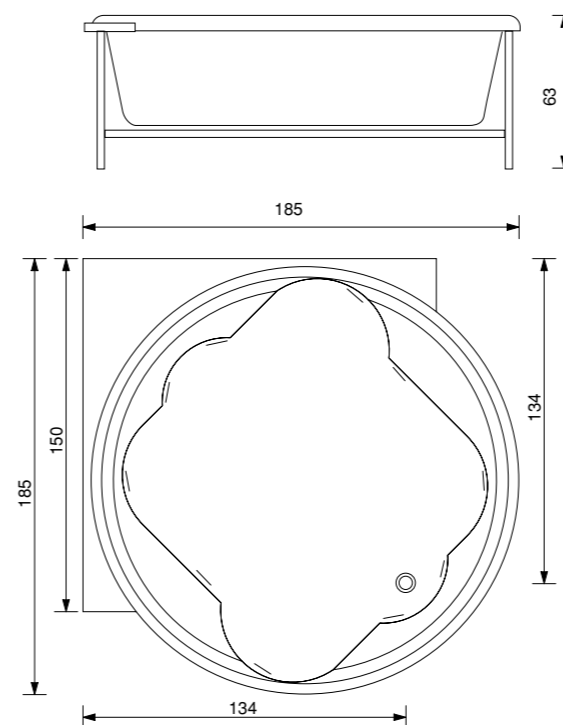

### DOTAZIONI E OPTIONAL

- DOPPIA SEDUTA INTERNA
- MANIGLIE DI SOSTEGNO
- IDROMASSAGGIO
- AIRPOOL
- SENSORE DI LIVELLO
- IMPIANTO DI DISINFEZIONE
- STABILIZZATORE TEMPERATURA ACQUA
- CROMOTERAPIA
- FARO
- RADIO
- INGRESSO AUDIO PER IPOD/CD
- OZONO TERAPIA
- RUBINETTERIA BORDO VASCA
- TELECOMANDO PER CONTROLLO FUNZIONI

### FOURNITURES ET OPTIONS

- DOUBLE ASSISE INTERNE
- POIGNEES DE SOUTIEN
- HYDROMASSAGE
- AIRPOOL
- CAPTEUR DE NIVEAU
- INSTALLATION DE DESINFECTION
- STABILISATEUR TEMPERATURE DE L'EAU
- CHROMOTHERAPIE
- SPOT
- RADIO
- ENTREE AUDIO POUR IPOD/CD
- OZONOTHERAPIE
- ROBINETTERIE REBORD DE BAIGNOIRE
- TELECOMMANDE POUR CONTROLE DES FONCTIONS

### FEATURES AND OPTIONALS

- INTERNAL TWIN SEATS
- GRAB BARS
- HYDROMASSAGE
- AIRPOOL
- LEVEL SENSOR
- DISINFECTION SYSTEM
- WATER TEMPERATURE STABILIZER
- COLOR THERAPY
- SPOTLIGHT
- RADIO
- AUDIO INPUT FOR IPOD/CD
- OZONE THERAPY
- TUB EDGE FAUCETS
- REMOTE CONTROL FOR FUNCTIONS

### CARACTERÍSTICAS Y COMPLEMENTOS

- DOBLE ASIENTO INTERIOR
- ASIDEROS DE APOYO
- HIDROMASAJE
- AIRPOOL
- SENSOR DE NIVEL
- SISTEMA DE DESINFECCIÓN
- ESTABILIZADOR DE LA TEMPERATURA DEL AGUA
- CROMOTERAPIA
- LUZ
- RADIO
- ENTRADA DE AUDIO PARA IPOD/CD
- OZONOTERAPIA
- GRIFERÍA EN EL BORDE DE LA BAÑERA
- MANDO A DISTANCIA PARA CONTROL DE LAS FUNCIONES

# Perla

182 X 182 X 63h.





## Perla

182 X 182 X 63h.

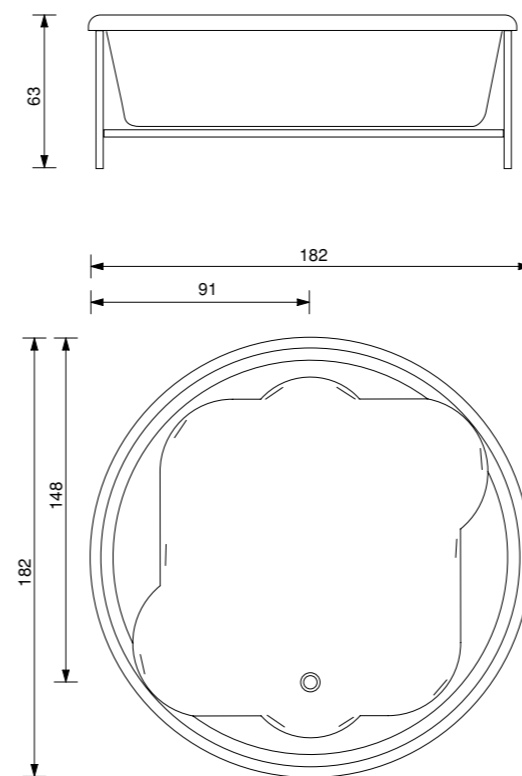

### DOTAZIONI E OPTIONAL

- DOPPIA SEDUTA INTERNA
- MANIGLIE DI SOSTEGNO
- IDROMASSAGGIO
- AIRPOOL
- SENSORE DI LIVELLO
- IMPIANTO DI DISINFEZIONE
- STABILIZZATORE TEMPERATURA ACQUA
- CROMOTERAPIA
- FARO
- RADIO
- INGRESSO AUDIO PER IPOD/CD
- OZONO TERAPIA
- RUBINETTERIA BORDO VASCA
- TELECOMANDO PER CONTROLLO FUNZIONI

### FOURNITURES ET OPTIONS

- DOUBLE ASSISE INTERNE
- POIGNEES DE SOUTIEN
- HYDROMASSAGE
- AIRPOOL
- CAPTEUR DE NIVEAU
- INSTALLATION DE DESINFECTION
- STABILISATEUR TEMPERATURE DE L'EAU
- CHROMOTHERAPIE
- SPOT
- RADIO
- ENTREE AUDIO POUR IPOD/CD
- OZONOTHERAPIE
- ROBINETTERIE REBORD DE BAIGNOIRE
- TELECOMMANDE POUR CONTROLE DES FONCTIONS

### FEATURES AND OPTIONALS

- INTERNAL TWIN SEATS
- GRAB BARS
- HYDROMASSAGE
- AIRPOOL
- LEVEL SENSOR
- DISINFECTION SYSTEM
- WATER TEMPERATURE STABILIZER
- COLOR THERAPY
- SPOTLIGHT
- RADIO
- AUDIO INPUT FOR IPOD/CD
- OZONE THERAPY
- TUB EDGE FAUCETS
- REMOTE CONTROL FOR FUNCTIONS

### CARACTERÍSTICAS Y COMPLEMENTOS

- DOBLE ASIENTO INTERIOR
- ASIDEROS DE APOYO
- HIDROMASAJE
- AIRPOOL
- SENSOR DE NIVEL
- SISTEMA DE DESINFECCIÓN
- ESTABILIZADOR DE LA TEMPERATURA DEL AGUA
- CROMOTERAPIA
- LUZ
- RADIO
- ENTRADA DE AUDIO PARA IPOD/CD
- OZONOTERAPIA
- GRIFERÍA EN EL BORDE DE LA BAÑERA
- MANDO A DISTANCIA PARA CONTROL DE LAS FUNCIONES

*Asyx*  
160 X 90 X 60h.



Page 92

*Dafne*  
150 X 150 X 60h.



96

*Dafne box*  
150 X 150 X 230h.



98

*Haiti*  
155 X 155 X 72h.



104

*Slide*  
140 X 140 X 63h.



108



Asyx

designer Paolo Parea

160 X 90 X 60h.



tresse

HOME

VASCHE ANGOLARI  
CORNERBATHTUBS

Asyx  
93





Asyx  
160 X 90 X 60h.

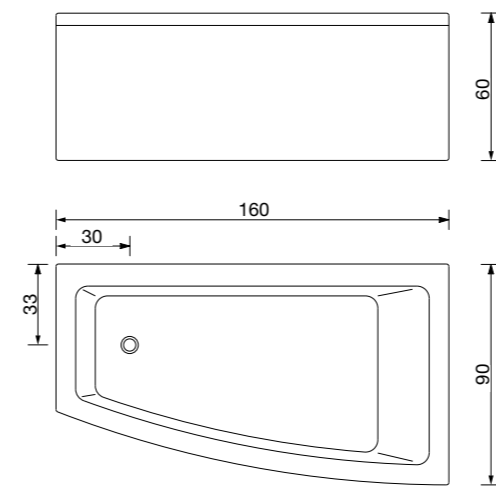

#### DOTAZIONI E OPTIONAL

- CUSCINO POGGIATESTA
- IDROMASSAGGIO
- AIRPOOL
- SENSORE DI LIVELLO
- IMPIANTO DI DISINFEZIONE
- STABILIZZATORE TEMPERATURA ACQUA
- CROMOTERAPIA
- FARO
- RADIO
- INGRESSO AUDIO PER IPOD/CD
- OZONO TERAPIA
- RUBINETTERIA BORDO VASCA
- TELECOMANDO PER CONTROLLO FUNZIONI

#### FOURNITURES ET OPTIONS

- COUSSIN REPOSE-TETE
- HYDROMASSAGE
- AIRPOOL
- CAPTEUR DE NIVEAU
- INSTALLATION DE DESINFECTION
- STABILISATEUR TEMPERATURE DE L'EAU
- CHROMOTHERAPIE
- SPOT
- RADIO
- ENTREE AUDIO POUR IPOD/CD
- OZONOTHERAPIE
- ROBINETTERIE REBORD DE BAIGNOIRE
- TELECOMMANDE POUR CONTROLE DES FONCTIONS

#### FEATURES AND OPTIONALS

- HEADREST CUSHION
- HYDROMASSAGE
- AIRPOOL
- LEVEL SENSOR
- DISINFECTION SYSTEM
- WATER TEMPERATURE STABILIZER
- COLOR THERAPY
- SPOTLIGHT
- RADIO
- AUDIO INPUT FOR IPOD/CD
- OZONE THERAPY
- TUB EDGE FAUCETS
- REMOTE CONTROL FOR FUNCTIONS

#### CARACTERÍSTICAS Y COMPLEMENTOS

- COJÍN REPOSACABEZAS
- HIDROMASAJE
- AIRPOOL
- SENSOR DE NIVEL
- SISTEMA DE DESINFECCIÓN
- ESTABILIZADOR DE LA TEMPERATURA DEL AGUA
- CROMOTERAPIA
- LUZ
- RADIO
- ENTRADA DE AUDIO PARA IPOD/CD
- OZONOTERAPIA
- GRIFERÍA EN EL BORDE DE LA BAÑERA
- MANDO A DISTANCIA PARA CONTROL DE LAS FUNCIONES



# Dafne

designer Paolo Parea

150 X 150 X 60h.

# Dafne box

designer Paolo Parea

150 X 150 X 230h.



trebbe

HOME

VASCHE ANGOLARI  
CORNERBATHTUBS

Dafne box  
99



# Dafne

150 X 150 X 60h.

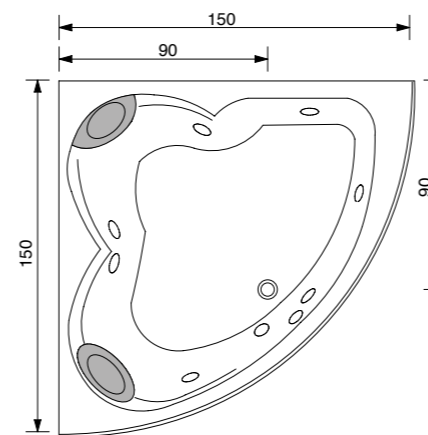
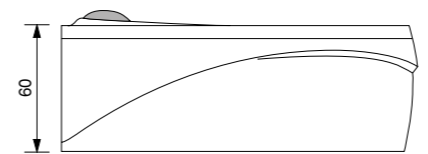

## DOTAZIONI E OPTIONAL

- DOPPIA SEDUTA INTERNA
- POGGIATESTA RIALZATI CON CUSCINO
- IDROMASSAGGIO
- AIRPOOL
- SENSORE DI LIVELLO
- IMPIANTO DI DISINFEZIONE
- STABILIZZATORE TEMPERATURA ACQUA
- CROMOTERAPIA
- FARO
- RADIO
- INGRESSO AUDIO PER IPOD/CD
- OZONO TERAPIA
- RUBINETTERIA BORDO VASCA
- TELECOMANDO PER CONTROLLO FUNZIONI

## FOURNITURES ET OPTIONS

- DOUBLE ASSISE INTERNE
- REPOSE-TETE REHAUSSES AVEC COUSSIN
- HYDROMASSAGE
- AIRPOOL
- CAPTEUR DE NIVEAU
- INSTALLATION DE DESINFECTION
- STABILISATEUR TEMPERATURE DE L'EAU
- CHROMOTHERAPIE
- SPOT
- RADIO
- ENTREE AUDIO POUR IPOD/CD
- OZONOTHERAPIE
- ROBINETTERIE REBORD DE BAIGNOIRE
- TELECOMMANDE POUR CONTROLE DES FONCTIONS

## FEATURES AND OPTIONALS

- INTERNAL TWIN SEATS
- RAISED HEADRESTS WITH CUSHION
- HYDROMASSAGE
- AIRPOOL
- LEVEL SENSOR
- DISINFECTION SYSTEM
- WATER TEMPERATURE STABILIZER
- COLOR THERAPY
- SPOTLIGHT
- RADIO
- AUDIO INPUT FOR IPOD/CD
- OZONE THERAPY
- TUB EDGE FAUCETS
- REMOTE CONTROL FOR FUNCTIONS

## CARACTERÍSTICAS Y COMPLEMENTOS

- DOBLE ASIENTO INTERIOR
- REPOSACABEZAS ELEVADOS CON COJÍN
- HIDROMASAJE
- AIRPOOL
- SENSOR DE NIVEL
- SISTEMA DE DESINFECCIÓN
- ESTABILIZADOR DE LA TEMPERATURA DEL AGUA
- CROMOTERAPIA
- LUZ
- RADIO
- ENTRADA DE AUDIO PARA IPOD/CD
- OZONOTERAPIA
- GRIFERÍA EN EL BORDE DE LA BAÑERA
- MANDO A DISTANCIA PARA CONTROL DE LAS FUNCIONES



# Dafne box

150 X 150 X 230h.

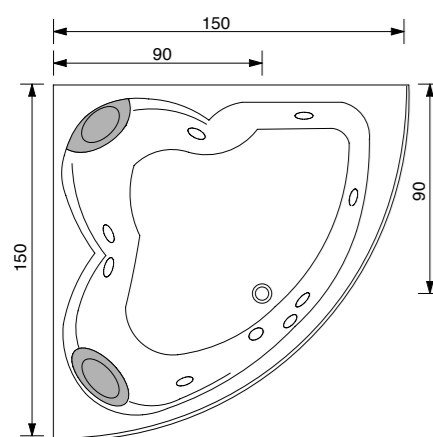
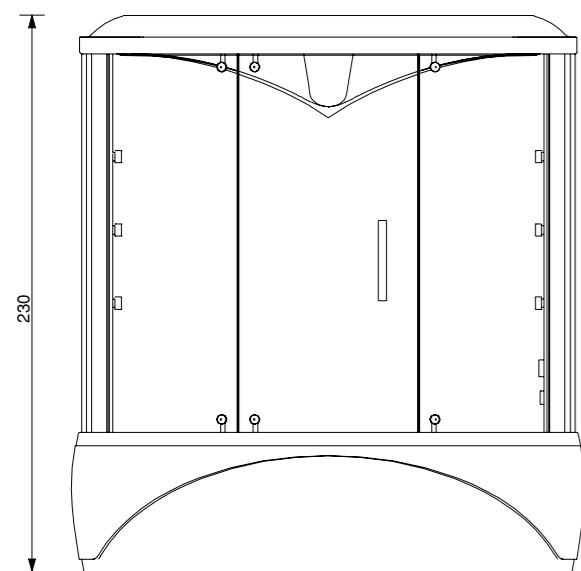

## DOTAZIONI E OPTIONAL

### VASCA:

- DOPPIA SEDUTA INTERNA
- POGGIATESTA RIALZATI CON CUSCINO
- IDROMASSAGGIO
- AIRPOOL
- SENSORE DI LIVELLO
- IMPIANTO DI DISINFEZIONE
- STABILIZZATORE TEMPERATURA ACQUA
- CROMOTERAPIA
- FARO
- RADIO
- INGRESSO AUDIO PER IPOD/CD
- OZONOTERAPIA
- RUBINETTERIA BORDO VASCA
- TELECOMANDO PER CONTROLLO FUNZIONI

### BOX:

- CRISTALLO TEMPERATO DA 6 MM
- BAGNO TURCO MONOCLIMA
- TETTO MULTIFUNZIONE
- DOCCIONE
- EROGAZIONE ACQUA CON CASCATA
- NEBULIZZATORI INTEGRATI SUL TETTO
- CROMOTERAPIA
- FARO
- COLONNA SOPRAVASCA CON RUBINETTERIA
- DOCCETTA CON SUPPORTO SNODATO
- JET MASSAGGIO VERTICALE
- MENSOLE PORTA OGGETTI

## FEATURES AND OPTIONALS

### BATHTUB:

- INTERNAL TWIN SEATS
- RAISED HEADRESTS WITH CUSHION
- HYDROMASSAGE
- AIRPOOL
- LEVEL SENSOR
- DISINFECTION SYSTEM
- WATER TEMPERATURE STABILIZER
- COLOR THERAPY
- SPOTLIGHT
- RADIO
- AUDIO INPUT FOR IPOD/CD
- OZONE THERAPY
- TUB EDGE FAUCETS
- REMOTE CONTROL FOR FUNCTIONS

### CUBICLE:

- TEMPERED GLASS, 6 MM
- SINGLE-SETTING STEAM BATH
- MULTIPURPOSE ROOF
- SHOWER HEAD
- WATERFALL FLOW
- BUILT-IN MISTERS ON ROOF
- COLOR THERAPY
- SPOTLIGHT
- ABOVE-BATH COLUMN WITH FAUCETS
- FLEX HAND UNIT
- VERTICAL MASSAGE JET
- TOILETRY SHELVES

## FOURNITURES ET OPTIONS

### BAIGNOIRE:

- DOUBLE ASSISE INTERNE
- REPOSE-TETES REHAUSSES AVEC COUSSIN
- HYDROMASSAGE
- AIRPOOL
- CAPTEUR DE NIVEAU
- INSTALLATION DE DESINFECTION
- STABILISATEUR TEMPERATURE DE L'EAU
- CHROMOTHERAPIE
- SPOT
- RADIO
- ENTREE AUDIO POUR IPOD/CD
- OZONOTHERAPIE
- ROBINETTERIE REBORD DE BAIGNOIRE
- TELECOMMANDE POUR CONTROLE DES FONCTIONS

### CABINE:

- VERRE TREMPE DE 6 MM
- BAIN TURC MONO-CLIMAT
- PLAFOND MULTIFONCTION
- POMME DE DOUCHE GRAND FORMAT
- DISTRIBUTION DE L'EAU EN CASCADE
- NEBULISEURS INTEGRES AU PLAFOND
- CHROMOTHERAPIE
- SPOT
- COLONNE AU-DESSUS DE LA BAIGNOIRE AVEC ROBINETTERIE
- DOUCHETTE AVEC SUPPORT ARTICULE
- JET MASSAGE VERTICAL
- ETAGERES PORTE-OBJETS

## CARACTERÍSTICAS Y COMPLEMENTOS

### BAÑERA:

- DOBLE ASIENTO INTERIOR
- REPOSACABEZAS ELEVADOS CON COJÍN
- HIDROMASAJE
- AIRPOOL
- SENSOR DE NIVEL
- SISTEMA DE DESINFECCIÓN
- ESTABILIZADOR DE LA TEMPERATURA DEL AGUA
- CROMOTERAPIA
- LUZ
- RADIO
- ENTRADA DE AUDIO PARA IPOD/CD
- OZONOTERAPIA
- GRIFERÍA EN EL BORDE DE LA BAÑERA
- MANDO A DISTANCIA PARA CONTROL DE LAS FUNCIONES

### CABINA:

- CRISTAL TEMPLADO DE 6 MM
- BAÑO TURCO MONOCLIMA
- TECHO MULTIFUNCIÓN
- ALCACHOFA CENTRAL
- SUMINISTRO DE AGUA A CASCADA
- NEBULIZADORES INTEGRADOS EN EL TECHO
- CROMOTERAPIA
- LUZ
- COLUMNA SOBRE LA BAÑERA CON GRIFERÍA
- ALCACHOFA CON SOPORTE ARTICULADO
- CHORRO MASAJE VERTICAL
- ESTANTES PORTAOBJETOS

Haiti

155 X 155 X 72h.



tresse

HOME

VASCHE ANGOLARI  
CORNERBATHTUBS

Haiti  
105



## Haiti

155 X 155 X 72h.

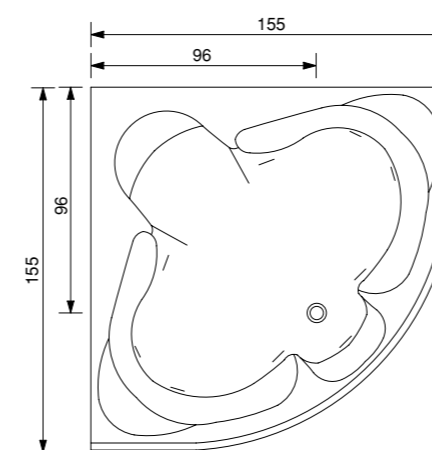
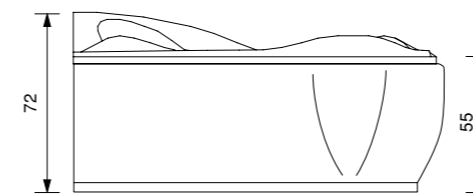

### DOTAZIONI E OPTIONAL

- DOPPIA SEDUTA INTERNA
- BRACCIOLI E POGGIATESTA INTEGRATI
- EROGAZIONE ACQUA CON CASCATA
- IDROMASSAGGIO
- AIRPOOL
- SENSORE DI LIVELLO
- IMPIANTO DI DISINFEZIONE
- STABILIZZATORE TEMPERATURA ACQUA
- CROMOTERAPIA
- FARO
- RADIO
- INGRESSO AUDIO PER IPOD/CD
- OZONO TERAPIA
- RUBINETTERIA BORDO VASCA
- TELECOMANDO PER CONTROLLO FUNZIONI

### FOURNITURES ET OPTIONS

- DOUBLE ASSISE INTERNE
- ACCOUDOIRS ET REPOSE-TETE INTEGRES
- DISTRIBUTION DE L'EAU EN CASCADE
- HYDROMASSAGE
- AIRPOOL
- CAPTEUR DE NIVEAU
- INSTALLATION DE DESINFECTION
- STABILISATEUR TEMPERATURE DE L'EAU
- CHROMOTHERAPIE
- SPOT
- RADIO
- ENTREE AUDIO POUR IPOD/CD
- OZONOTHERAPIE
- ROBINETTERIE REBORD DE BAIGNOIRE
- TELECOMMANDE POUR CONTROLE DES FONCTIONS

### FEATURES AND OPTIONALS

- INTERNAL TWIN SEATS
- BUILT-IN ARM AND HEADREST
- WATERFALL FLOW
- HYDROMASSAGE
- AIRPOOL
- LEVEL SENSOR
- DISINFECTION SYSTEM
- WATER TEMPERATURE STABILIZER
- COLOR THERAPY
- SPOTLIGHT
- RADIO
- AUDIO INPUT FOR IPOD/CD
- OZONE THERAPY
- TUB EDGE FAUCETS
- REMOTE CONTROL FOR FUNCTIONS

### CARACTERÍSTICAS Y COMPLEMENTOS

- DOBLE ASIENTO INTERIOR
- REPOSABRAZOS Y REPOSACABEZAS INTEGRADOS
- SUMINISTRO DE AGUA A CASCADA
- HIDROMASAJE
- AIRPOOL
- SENSOR DE NIVEL
- SISTEMA DE DESINFECCIÓN
- ESTABILIZADOR DE LA TEMPERATURA DEL AGUA
- CROMOTERAPIA
- LUZ
- RADIO
- ENTRADA DE AUDIO PARA IPOD/CD
- OZONOTERAPIA
- GRIFERÍA EN EL BORDE DE LA BAÑERA
- MANDO A DISTANCIA PARA CONTROL DE LAS FUNCIONES

# Slide

designer Fabrizio Batoni

140 X 140 X 63h.



tresse

HOME

VASCHE ANGOLARI  
CORNERBATHTUBS

Slide  
109







Slide  
140 X 140 X 63h.

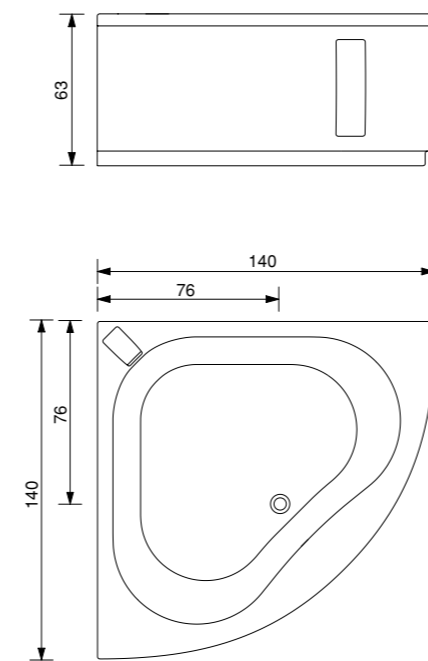

**DOTAZIONI E OPTIONAL**

- DOPPIA SEDUTA INTERNA
- PANNELLO ESTERNO CON LUCE DI CORTESIA
- TROPPO PIENO A SKIMMER
- IDROMASSAGGIO
- AIRPOOL
- SENSORE DI LIVELLO
- IMPIANTO DI DISINFEZIONE
- STABILIZZATORE TEMPERATURA ACQUA
- CROMOTERAPIA
- FARO
- RADIO
- INGRESSO AUDIO PER IPOD/CD
- OZONO TERAPIA
- RUBINETTERIA BORDO VASCA
- TELECOMANDO PER CONTROLLO FUNZIONI

**FOURNITURES ET OPTIONS**

- DOUBLE ASSISE INTERNE
- PANNEAU EXTERNE AVEC ECLAIRAGE DE COURTOISIE
- TROP-PLEIN DE TYPE SKIMMER
- HYDROMASSAGE
- AIRPOOL
- CAPTEUR DE NIVEAU
- INSTALLATION DE DESINFECTION
- STABILISATEUR TEMPERATURE DE L'EAU
- CHROMOTHERAPIE
- SPOT
- RADIO
- ENTREE AUDIO POUR IPOD/CD
- OZONOTHERAPIE
- ROBINETTERIE REBORD DE BAIGNOIRE
- TELECOMMANDE POUR CONTROLE DES FONCTIONS

**FEATURES AND OPTIONALS**

- INTERNAL TWIN SEATS
- OUTER PANEL WITH COURTESY LIGHT
- OVERFLOW SKIMMER
- HYDROMASSAGE
- AIRPOOL
- LEVEL SENSOR
- DISINFECTION SYSTEM
- WATER TEMPERATURE STABILIZER
- COLOR THERAPY
- SPOTLIGHT
- RADIO
- AUDIO INPUT FOR IPOD/CD
- OZONE THERAPY
- TUB EDGE FAUCETS
- REMOTE CONTROL FOR FUNCTIONS

**CARACTERÍSTICAS Y COMPLEMENTOS**

- DOBLE ASIENTO INTERIOR
- PANEL EXTERIOR CON LUZ DE CORTESÍA
- REBOSADERO SKIMMER
- HIDROMASAJE
- AIRPOOL
- SENSOR DE NIVEL
- SISTEMA DE DESINFECCIÓN
- ESTABILIZADOR DE LA TEMPERATURA DEL AGUA
- CROMOTERAPIA
- LUZ
- RADIO
- ENTRADA DE AUDIO PARA IPOD/CD
- OZONOTERAPIA
- GRIFERÍA EN EL BORDE DE LA BAÑERA
- MANDO A DISTANCIA PARA CONTROL DE LAS FUNCIONES

*Alba*

170 X 80 X 70h.  
180 X 90 X 70h.



Page 116

*Alba box*

170 X 80 X 215h.  
180 X 90 X 215h.



120

*Alba box easy*

170 X 80 X 215h.  
180 X 90 X 215h.



122

*Crystal line*

180 X 80 X 64h.



128

*New classic*

170 X 85 X 57h.



132

*New classic young*

170 X 85 X 57h.



136

*Playa*

180 X 70 X 64h.



142

*Quadra*

170 X 70 X 59h.  
170 X 80 X 59h.  
180 X 80 X 63h.  
180 X 100 X 59h.



Page 148

*Quadra line*

180 X 80 X 63h.



154

*Quadra box*

170 X 70 X 215h.  
170 X 80 X 215h.  
180 X 80 X 219h.



156

*Quadra box easy*

170 X 70 X 215h.  
170 X 80 X 215h.  
180 X 80 X 219h.



158

*Spider*

180 X 80 X 68h.



166

*Thesis*

170 X 80 X 60h.



172

*Vision*

180 X 80 X 60h.



178

# Alba

designer Paolo Parea

170 X 80 X 70h. 180 X 90 X 70h.



# Alba box

designer Paolo Parea

170 X 80 X 215h. 180 X 90 X 215h.



tresse

HOME

VASCHE RETTANGOLARI  
RECTANGULAR BATHTUBS

Alba box  
121



# Alba box easy

designer Paolo Parea

170 X 80 X 215h. 180 X 90 X 215h.



Alba box easy 2  
123



## Alba

170 X 80 X 70h. 180 X 90 X 70h.

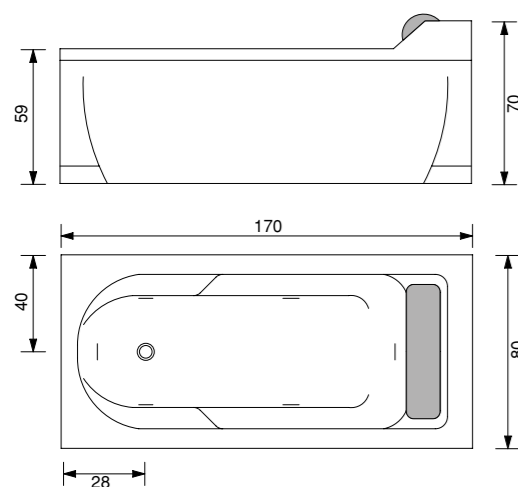

### DOTAZIONI E OPTIONAL

- MANIGLIE DI SOSTEGNO
- POGGIATESTA RIALZATO CON CUSCINO
- IDROMASSAGGIO
- AIRPOOL
- SENSORE DI LIVELLO
- IMPIANTO DI DISINFEZIONE
- STABILIZZATORE TEMPERATURA ACQUA
- CROMOTERAPIA
- FARO
- RADIO
- INGRESSO AUDIO PER IPOD/CD
- OZONO TERAPIA
- RUBINETTERIA BORDO VASCA
- TELECOMANDO PER CONTROLLO FUNZIONI

### FOURNITURES ET OPTIONS

- POIGNEES DE SOUTIEN
- REPOSE-TETE REHAUSSE AVEC COUSSIN
- HYDROMASSAGE
- AIRPOOL
- CAPTEUR DE NIVEAU
- INSTALLATION DE DESINFECTION
- STABILISATEUR TEMPERATURE DE L'EAU
- CHROMOTHERAPIE
- SPOT
- RADIO
- ENTREE AUDIO POUR IPOD/CD
- OZONOTHERAPIE
- ROBINETTERIE REBORD DE BAIGNOIRE
- TELECOMMANDE POUR CONTROLE DES FONCTIONS

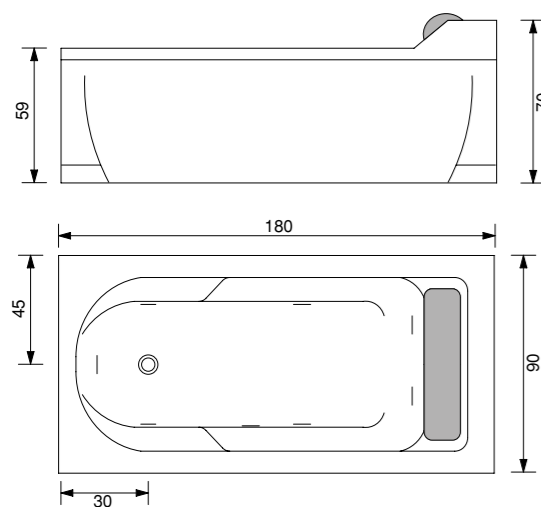

### FEATURES AND OPTIONALS

- GRAB BARS
- RAISED HEADREST WITH CUSHION
- HYDROMASSAGE
- AIRPOOL
- LEVEL SENSOR
- DISINFECTION SYSTEM
- WATER TEMPERATURE STABILIZER
- COLOR THERAPY
- SPOTLIGHT
- RADIO
- AUDIO INPUT FOR IPOD/CD
- OZONE THERAPY
- TUB EDGE FAUCETS
- REMOTE CONTROL FOR FUNCTIONS

### CARACTERÍSTICAS Y COMPLEMENTOS

- ASIDEROS DE APOYO
- REPOSACABEZAS ELEVADO CON COJÍN
- HIDROMASAJE
- AIRPOOL
- SENSOR DE NIVEL
- SISTEMA DE DESINFECCIÓN
- ESTABILIZADOR DE LA TEMPERATURA DEL AGUA
- CROMOTERAPIA
- LUZ
- RADIO
- ENTRADA DE AUDIO PARA IPOD/CD
- OZONOTERAPIA
- GRIFERÍA EN EL BORDE DE LA BAÑERA
- MANDO A DISTANCIA PARA CONTROL DE LAS FUNCIONES



## Alba box

170 X 80 X 215h. 180 X 90 X 215h.

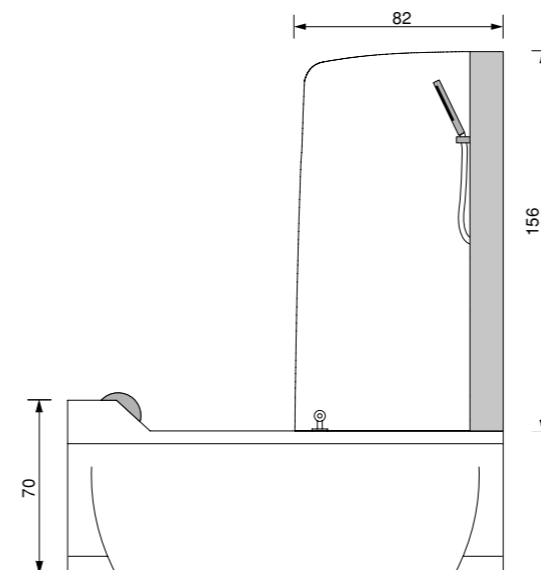

### DOTAZIONI E OPTIONAL

#### VASCA:

- MANIGLIE DI SOSTEGNO
- POGGIATESTA RIALZATO CON CUSCINO
- IDROMASSAGGIO
- AIRPOOL
- SENSORE DI LIVELLO
- IMPIANTO DI DISINFEZIONE
- STABILIZZATORE TEMPERATURA ACQUA
- CROMOTERAPIA
- FARO
- RADIO
- INGRESSO AUDIO PER IPOD/CD
- OZONO TERAPIA
- RUBINETTERIA BORDO VASCA
- TELECOMANDO PER CONTROLLO FUNZIONI

#### BOX:

- CRISTALLO TEMPERATO DA 6 MM
- COLONNA SOPRAVASCA CON RUBINETTERIA
- DOCCETTA CON SUPPORTO SNODATO
- JET MASSAGGIO VERTICALE
- MENSOLA PORTA OGGETTI

### FOURNITURES ET OPTIONS

#### BAIGNOIRE:

- POIGNEES DE SOUTIEN
- REPOSE-TETE REHAUSSE AVEC COUSSIN
- HYDROMASSAGE
- AIRPOOL
- CAPTEUR DE NIVEAU
- INSTALLATION DE DESINFECTION
- STABILISATEUR TEMPERATURE DE L'EAU
- CHROMOTHERAPIE
- SPOT
- RADIO
- ENTREE AUDIO POUR IPOD/CD
- OZONOTHERAPIE
- ROBINETTERIE REBORD DE BAIGNOIRE
- TELECOMMANDE POUR CONTROLE DES FONCTIONS

#### CABINE:

- VERRE TREMPÉ DE 6 MM
- COLONNE AU-DESSUS DE LA BAIGNOIRE AVEC ROBINETTERIE
- DOUCHETTE AVEC SUPPORT ARTICULE
- JET MASSAGE VERTICAL
- ETAGERE PORTE-OBJETS

### FEATURES AND OPTIONALS

#### BATHTUB:

- GRAB BARS
- RAISED HEADREST WITH CUSHION
- HYDROMASSAGE
- AIRPOOL
- LEVEL SENSOR
- DISINFECTION SYSTEM
- WATER TEMPERATURE STABILIZER
- COLOR THERAPY
- SPOTLIGHT
- RADIO
- AUDIO INPUT FOR IPOD/CD
- OZONE THERAPY
- TUB EDGE FAUCETS
- REMOTE CONTROL FOR FUNCTIONS

#### CUBICLE:

- TEMPERED GLASS, 6 MM
- ABOVE-BATH COLUMN WITH FAUCETS
- FLEX HAND UNIT
- VERTICAL MASSAGE JET
- TOILETRY SHELF

### CARACTERÍSTICAS Y COMPLEMENTOS

#### BAÑERA:

- ASIDEROS DE APOYO
- REPOSACABEZAS ELEVADO CON COJÍN
- HIDROMASAJE
- AIRPOOL
- SENSOR DE NIVEL
- SISTEMA DE DESINFECCIÓN
- ESTABILIZADOR DE LA TEMPERATURA DEL AGUA
- CROMOTERAPIA
- LUZ
- RADIO
- ENTRADA DE AUDIO PARA IPOD/CD
- OZONOTERAPIA
- GRIFERÍA EN EL BORDE DE LA BAÑERA
- MANDO A DISTANCIA PARA CONTROL DE LAS FUNCIONES

#### CABINA:

- CRISTAL TEMPLADO DE 6 MM
- COLUMNA SOBRE LA BAÑERA CON GRIFERÍA
- ALCACHOFA CON SOPORTE ARTICULADO
- CHORRO MASAJE VERTICAL
- ESTANTE PORTAOBJETOS





## Alba box easy

170 X 80 X 215h. 180 X 90 X 215h.

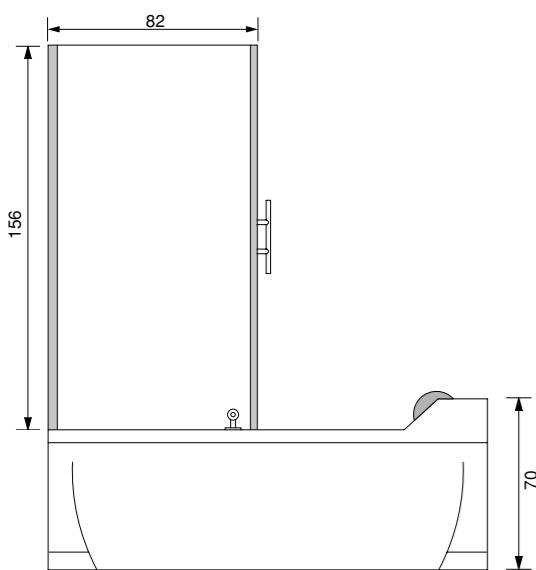

### DOTAZIONI E OPTIONAL

#### VASCA:

- MANIGLIE DI SOSTEGNO
- POGGIATESTA RIALZATO CON CUSCINO
- IDROMASSAGGIO
- AIRPOOL
- SENSORE DI LIVELLO
- IMPIANTO DI DISINFEZIONE
- STABILIZZATORE TEMPERATURA ACQUA
- CROMOTERAPIA
- FARO
- RADIO
- INGRESSO AUDIO PER IPOD/CD
- OZONO TERAPIA
- RUBINETTERIA BORDO VASCA
- TELECOMANDO PER CONTROLLO FUNZIONI

#### BOX:

- CRISTALLO TEMPERATO DA 6 MM

### FOURNITURES ET OPTIONS

#### BAIGNOIRE:

- POIGNEES DE SOUTIEN
- REPOSE-TETE REHAUSSE AVEC COUSSIN
- HYDROMASSAGE
- AIRPOOL
- CAPTEUR DE NIVEAU
- INSTALLATION DE DESINFECTION
- STABILISATEUR TEMPERATURE DE L'EAU
- CHROMOTHERAPIE
- SPOT
- RADIO
- ENTREE AUDIO POUR IPOD/CD
- OZONOTHERAPIE
- ROBINETTERIE REBORD DE BAIGNOIRE
- TELECOMMANDE POUR CONTROLE DES FONCTIONS

#### CABINE:

- VERRE TREMPE DE 6 MM

### FEATURES AND OPTIONALS

#### BATHTUB:

- GRAB BARS
- RAISED HEADREST WITH CUSHION
- HYDROMASSAGE
- AIRPOOL
- LEVEL SENSOR
- DISINFECTION SYSTEM
- WATER TEMPERATURE STABILIZER
- COLOR THERAPY
- SPOTLIGHT
- RADIO
- AUDIO INPUT FOR IPOD/CD
- OZONE THERAPY
- TUB EDGE FAUCETS
- REMOTE CONTROL FOR FUNCTIONS

#### CUBICLE:

- TEMPERED GLASS, 6 MM

### CARACTERÍSTICAS Y COMPLEMENTOS

#### BAÑERA:

- ASIDEROS DE APOYO
- REPOSACABEZAS ELEVADO CON COJÍN
- HIDROMASAJE
- AIRPOOL
- SENSOR DE NIVEL
- SISTEMA DE DESINFECCIÓN
- ESTABILIZADOR DE LA TEMPERATURA DEL AGUA
- CROMOTERAPIA
- LUZ
- RADIO
- ENTRADA DE AUDIO PARA IPOD/CD
- OZONOTERAPIA
- GRIFERÍA EN EL BORDE DE LA BAÑERA
- MANDO A DISTANCIA PARA CONTROL DE LAS FUNCIONES

#### CABINA:

- CRISTAL TEMPLADO DE 6 MM



## Alba box easy 2

170 X 80 X 215h. 180 X 90 X 215h.

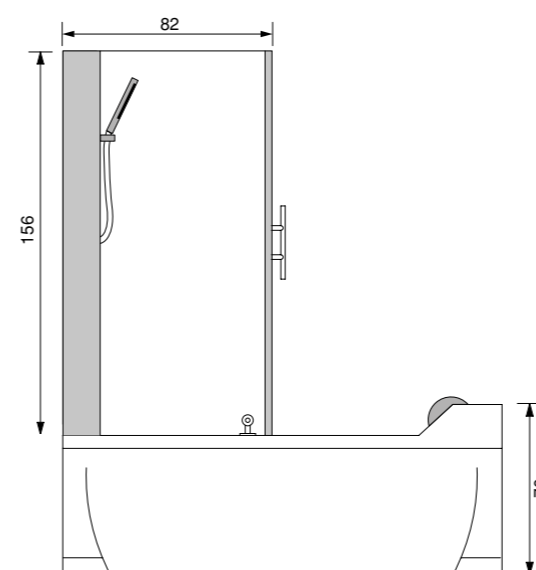

### DOTAZIONI E OPTIONAL

#### VASCA:

- MANIGLIE DI SOSTEGNO
- POGGIATESTA RIALZATO CON CUSCINO
- IDROMASSAGGIO
- AIRPOOL
- SENSORE DI LIVELLO
- IMPIANTO DI DISINFEZIONE
- STABILIZZATORE TEMPERATURA ACQUA
- CROMOTERAPIA
- FARO
- RADIO
- INGRESSO AUDIO PER IPOD/CD
- OZONO TERAPIA
- RUBINETTERIA BORDO VASCA
- TELECOMANDO PER CONTROLLO FUNZIONI

#### BOX:

- CRISTALLO TEMPERATO DA 6 MM
- COLONNA SOPRAVASCA CON RUBINETTERIA
- DOCCETTA CON SUPPORTO SNODATO
- JET MASSAGGIO VERTICALE
- MENSOLA PORTA OGGETTI

### FOURNITURES ET OPTIONS

#### BAIGNOIRE:

- POIGNEES DE SOUTIEN
- REPOSE-TETE REHAUSSE AVEC COUSSIN
- HYDROMASSAGE
- AIRPOOL
- CAPTEUR DE NIVEAU
- INSTALLATION DE DESINFECTION
- STABILISATEUR TEMPERATURE DE L'EAU
- CHROMOTHERAPIE
- SPOT
- RADIO
- ENTREE AUDIO POUR IPOD/CD
- OZONOTHERAPIE
- ROBINETTERIE REBORD DE BAIGNOIRE
- TELECOMMANDE POUR CONTROLE DES FONCTIONS

#### CABINE:

- VERRE TREMPE DE 6 MM
- COLONNE AU-DESSUS DE LA BAIGNOIRE AVEC ROBINETTERIE
- DOUCHETTE AVEC SUPPORT ARTICULE
- JET MASSAGE VERTICAL
- ETAGERE PORTE-OBJETS

### FEATURES AND OPTIONALS

#### BATHTUB:

- GRAB BARS
- RAISED HEADREST WITH CUSHION
- HYDROMASSAGE
- AIRPOOL
- LEVEL SENSOR
- DISINFECTION SYSTEM
- WATER TEMPERATURE STABILIZER
- COLOR THERAPY
- SPOTLIGHT
- RADIO
- AUDIO INPUT FOR IPOD/CD
- OZONE THERAPY
- TUB EDGE FAUCETS
- REMOTE CONTROL FOR FUNCTIONS

#### CUBICLE:

- TEMPERED GLASS, 6 MM
- ABOVE-BATH COLUMN WITH FAUCETS
- FLEX HAND UNIT
- VERTICAL MASSAGE JET
- TOILETRY SHELF

### CARACTERÍSTICAS Y COMPLEMENTOS

#### BAÑERA:

- ASIDEROS DE APOYO
- REPOSACABEZAS ELEVADO CON COJÍN
- HIDROMASAJE
- AIRPOOL
- SENSOR DE NIVEL
- SISTEMA DE DESINFECCIÓN
- ESTABILIZADOR DE LA TEMPERATURA DEL AGUA
- CROMOTERAPIA
- LUZ
- RADIO
- ENTRADA DE AUDIO PARA IPOD/CD
- OZONOTERAPIA
- GRIFERÍA EN EL BORDE DE LA BAÑERA
- MANDO A DISTANCIA PARA CONTROL DE LAS FUNCIONES

#### CABINA:

- CRISTAL TEMPLADO DE 6 MM
- COLUMNA SOBRE LA BAÑERA CON GRIFERÍA
- ALCACHOFA CON SOPORTE ARTICULADO
- CHORRO MASAJE VERTICAL
- ESTANTE PORTAOBJETOS

# Crystal line

designer Paolo Parea

180 X 80 X 64h.



tresse

HOME

VASCHE RETTANGOLARI  
RECTANGULAR BATHTUBS

Crystal line  
129



## Crystal line

180 X 80 X 64h.

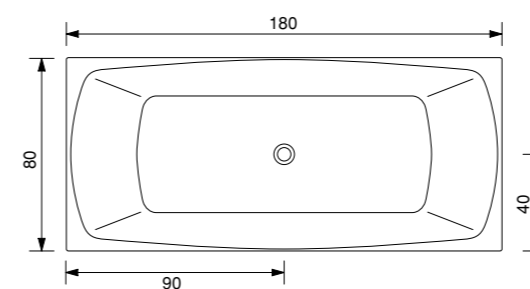
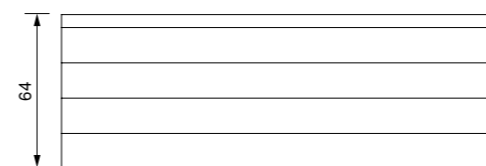

### DOTAZIONI E OPTIONAL

- POGGIATESTA IN SKY
- PANNELLO ESTERNO CON FINITURE IN ACCIAIO LUCIDO/ORO
- IDROMASSAGGIO
- AIRPOOL
- SENSORE DI LIVELLO
- IMPIANTO DI DISINFEZIONE
- STABILIZZATORE TEMPERATURA ACQUA
- CROMOTERAPIA
- FARO
- RADIO
- INGRESSO AUDIO PER IPOD/CD
- OZONO TERAPIA
- RUBINETTERIA BORDO VASCA
- TELECOMANDO PER CONTROLLO FUNZIONI

### FOURNITURES ET OPTIONS

- REPOSE-TETE EN SIMILI CUIR
- PANNEAU EXTERNE AVEC FINITIONS EN ACIER POLI/OR
- HYDROMASSAGE
- AIRPOOL
- CAPTEUR DE NIVEAU
- INSTALLATION DE DESINFECTION
- STABILISATEUR TEMPERATURE DE L'EAU
- CHROMOTHERAPIE
- SPOT
- RADIO
- ENTREE AUDIO POUR IPOD/CD
- OZONOTHERAPIE
- ROBINETTERIE REBORD DE BAIGNOIRE
- TELECOMMANDE POUR CONTROLE DES FONCTIONS

### FEATURES AND OPTIONALS

- FAUX LEATHER HEADREST
- OUTER PANEL WITH GLOSSY STEEL/GOLD FINISHES
- HYDROMASSAGE
- AIRPOOL
- LEVEL SENSOR
- DISINFECTION SYSTEM
- WATER TEMPERATURE STABILIZER
- COLOR THERAPY
- SPOTLIGHT
- RADIO
- AUDIO INPUT FOR IPOD/CD
- OZONE THERAPY
- TUB EDGE FAUCETS
- REMOTE CONTROL FOR FUNCTIONS

### CARACTERÍSTICAS Y COMPLEMENTOS

- REPOSACABEZAS DE POLIPIEL
- PANEL EXTERIOR CON ACABADOS EN ACERO BRILLANTE/ORO
- HIDROMASAJE
- AIRPOOL
- SENSOR DE NIVEL
- SISTEMA DE DESINFECCIÓN
- ESTABILIZADOR DE LA TEMPERATURA DEL AGUA
- CROMOTERAPIA
- LUZ
- RADIO
- ENTRADA DE AUDIO PARA IPOD/CD
- OZONOTERAPIA
- GRIFERÍA EN EL BORDE DE LA BAÑERA
- MANDO A DISTANCIA PARA CONTROL DE LAS FUNCIONES



*New classic*

170 X 85 X 57h.



*New classic*  
133

tresse  
HOME

VASCHE RETTANGOLARI  
RECTANGULAR BATHUBS



# New classic young

designer Anika Elisabetta Luceri

170 X 85 X 57h.

New classic young

137





## New classic

170 X 85 X 57h.

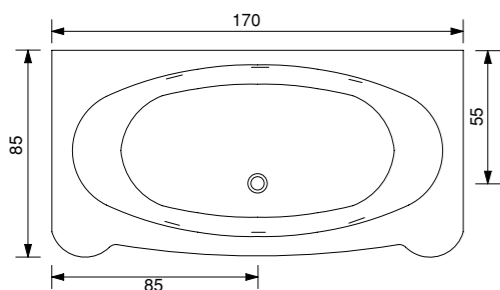
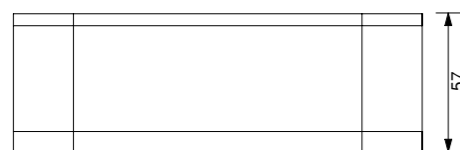

### DOTAZIONI E OPTIONAL

- PANNELLI ESTERNI: CLASSICI IN STILE IN LEGNO CON FINITURE IN NOCE O WENGE'
- IDROMASSAGGIO
- AIRPOOL
- SENSORE DI LIVELLO
- IMPIANTO DI DISINFEZIONE
- STABILIZZATORE TEMPERATURA ACQUA
- CROMOTERAPIA
- FARO
- RADIO
- INGRESSO AUDIO PER IPOD/CD
- OZONO TERAPIA
- RUBINETTERIA BORDO VASCA
- TELECOMANDO PER CONTROLLO FUNZIONI

### FOURNITURES ET OPTIONS

- PANNEAUX EXTERNES: STYLE CLASSIQUE EN BOIS AVEC FINITIONS EN NOYER OU WENGE
- HYDROMASSAGE
- AIRPOOL
- CAPTEUR DE NIVEAU
- INSTALLATION DE DESINFECTION
- STABILISATEUR TEMPERATURE DE L'EAU
- CHROMOTHERAPIE
- SPOT
- RADIO
- ENTREE AUDIO POUR IPOD/CD
- OZONOTHERAPIE
- ROBINETTERIE REBORD DE BAIGNOIRE
- TELECOMMANDE POUR CONTROLE DES FONCTIONS

### FEATURES AND OPTIONALS

- OUTER PANELS: CLASSIC-STYLE PANELS WOOD WITH WALNUT OR WENGE FINISHES
- HYDROMASSAGE
- AIRPOOL
- LEVEL SENSOR
- DISINFECTION SYSTEM
- WATER TEMPERATURE STABILIZER
- COLOR THERAPY
- SPOTLIGHT
- RADIO
- AUDIO INPUT FOR IPOD/CD
- OZONE THERAPY
- TUB EDGE FAUCETS
- REMOTE CONTROL FOR FUNCTIONS

### CARACTERÍSTICAS Y COMPLEMENTOS

- PANELES EXTERIORES: DE ESTILO CLÁSICO DE MANERA CON ACABADOS EN NOGAL O WENGUÉ
- HIDROMASAJE
- AIRPOOL
- SENSOR DE NIVEL
- SISTEMA DE DESINFECCIÓN
- ESTABILIZADOR DE LA TEMPERATURA DEL AGUA
- CROMOTERAPIA
- LUZ
- RADIO
- ENTRADA DE AUDIO PARA IPOD/CD
- OZONOTERAPIA
- GRIFERÍA EN EL BORDE DE LA BAÑERA
- MANDO A DISTANCIA PARA CONTROL DE LAS FUNCIONES



## New classic young

170 X 85 X 57h.

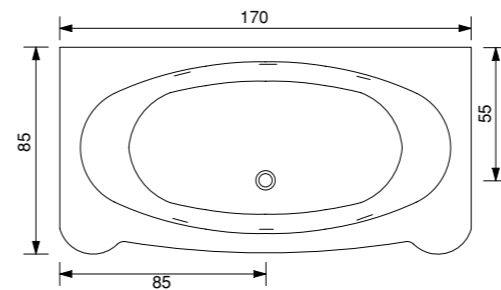
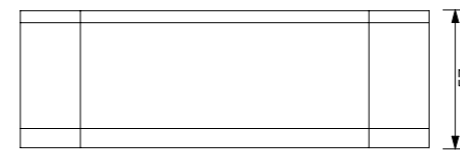

### DOTAZIONI E OPTIONAL

- PANNELLI ESTERNI: IN PELLE CON LAVORAZIONE CAPITONNE' E BOTTONI IN SWAROVSKI
- IDROMASSAGGIO
- AIRPOOL
- SENSORE DI LIVELLO
- IMPIANTO DI DISINFEZIONE
- STABILIZZATORE TEMPERATURA ACQUA
- CROMOTERAPIA
- FARO
- RADIO
- INGRESSO AUDIO PER IPOD/CD
- OZONO TERAPIA
- RUBINETTERIA BORDO VASCA
- TELECOMANDO PER CONTROLLO FUNZIONI

### FOURNITURES ET OPTIONS

- PANNEAUX EXTERNES : EN CUIR CAPITONNE ET BOUTONS EN SWAROVSKI
- HYDROMASSAGE
- AIRPOOL
- CAPTEUR DE NIVEAU
- INSTALLATION DE DESINFECTION
- STABILISATEUR TEMPERATURE DE L'EAU
- CHROMOTHERAPIE
- SPOT
- RADIO
- ENTREE AUDIO POUR IPOD/CD
- OZONOTHERAPIE
- ROBINETTERIE REBORD DE BAIGNOIRE
- TELECOMMANDE POUR CONTROLE DES FONCTIONS

### FEATURES AND OPTIONALS

- OUTER PANELS: BUTTON-TUFTED LEATHER AND SWAROVSKI BUTTONS
- HYDROMASSAGE
- AIRPOOL
- LEVEL SENSOR
- DISINFECTION SYSTEM
- WATER TEMPERATURE STABILIZER
- COLOR THERAPY
- SPOTLIGHT
- RADIO
- AUDIO INPUT FOR IPOD/CD
- OZONE THERAPY
- TUB EDGE FAUCETS
- REMOTE CONTROL FOR FUNCTIONS

### CARACTERÍSTICAS Y COMPLEMENTOS

- PANELES EXTERIORES: DE PIEL CON ACABADO ACOLCHADO Y BOTONES DE SWAROVSKI
- HIDROMASAJE
- AIRPOOL
- SENSOR DE NIVEL
- SISTEMA DE DESINFECCIÓN
- ESTABILIZADOR DE LA TEMPERATURA DEL AGUA
- CROMOTERAPIA
- LUZ
- RADIO
- ENTRADA DE AUDIO PARA IPOD/CD
- OZONOTERAPIA
- GRIFERÍA EN EL BORDE DE LA BAÑERA
- MANDO A DISTANCIA PARA CONTROL DE LAS FUNCIONES



# Playa

designer Alessandro Lenarda

180 X 70 X 64h.





Playa  
180 X 70 X 64h.

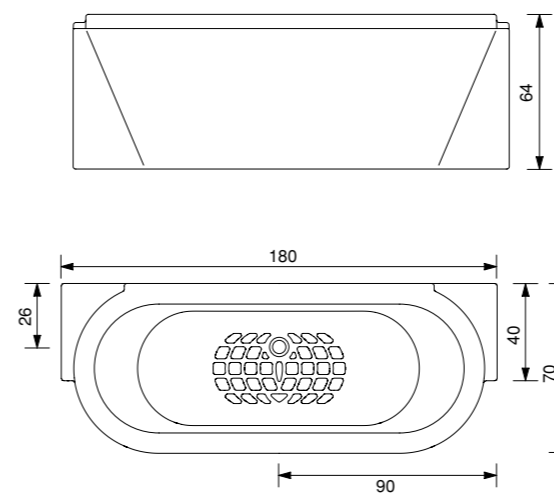

**DOTAZIONI E OPTIONAL**

- IDROMASSAGGIO
- AIRPOOL
- SENSORE DI LIVELLO
- IMPIANTO DI DISINFEZIONE
- STABILIZZATORE TEMPERATURA ACQUA
- CROMOTERAPIA
- FARO
- RADIO
- INGRESSO AUDIO PER IPOD/CD
- OZONO TERAPIA
- RUBINETTERIA BORDO VASCA
- TELECOMANDO PER CONTROLLO FUNZIONI

**FOURNITURES ET OPTIONS**

- HYDROMASSAGE
- AIRPOOL
- CAPTEUR DE NIVEAU
- INSTALLATION DE DESINFECTION
- STABILISATEUR TEMPERATURE DE L'EAU
- CHROMOTHERAPIE
- SPOT
- RADIO
- ENTREE AUDIO POUR IPOD/CD
- OZONOTHERAPIE
- ROBINETTERIE REBORD DE BAIGNOIRE
- TELECOMMANDE POUR CONTROLE DES FONCTIONS

**FEATURES AND OPTIONALS**

- HYDROMASSAGE
- AIRPOOL
- LEVEL SENSOR
- DISINFECTION SYSTEM
- WATER TEMPERATURE STABILIZER
- COLOR THERAPY
- SPOTLIGHT
- RADIO
- AUDIO INPUT FOR IPOD/CD
- OZONE THERAPY
- TUB EDGE FAUCETS
- REMOTE CONTROL FOR FUNCTIONS

**CARACTERÍSTICAS Y COMPLEMENTOS**

- HIDROMASAJE
- AIRPOOL
- SENSOR DE NIVEL
- SISTEMA DE DESINFECCIÓN
- ESTABILIZADOR DE LA TEMPERATURA DEL AGUA
- CROMOTERAPIA
- LUZ
- RADIO
- ENTRADA DE AUDIO PARA IPOD/CD
- OZONOTERAPIA
- GRIFERÍA EN EL BORDE DE LA BAÑERA
- MANDO A DISTANCIA PARA CONTROL DE LAS FUNCIONES



# Quadra

170 X 70 X 59h. 170 X 80 X 59h. 180 X 80 X 63h. 180 X 100 X 59h.



treesse

HOME

VASCHE RETTANGOLARI  
RECTANGULAR BATHS

Quadra 180 X 100

149







# Quadra line

designer Paolo Parea

180 X 80 X 63h.



tresse

HOME

VASCHE RETTANGOLARI  
RECTANGULAR BATHUBS

Quadra line  
155

# Quadra box

designer Paolo Parea

170 X 70 X 215h. 170 X 80 X 215h. 180 X 80 X 219h.



tresse

HOME

VASCHE RETTANGOLARI  
RECTANGULAR BATHS

Quadra box  
157





# Quadra box easy

designer Paolo Parea

170 X 70 X 215h. 170 X 80 X 215h. 180 X 80 X 219h.



tresse

HOME

VASCHE RETTANGOLARI  
RECTANGULAR BATHUBS

Quadra box easy 2  
159



# Quadra

170 X 70 X 59h. 170 X 80 X 59h. 180 X 80 X 63h. 180 X 100 X 59h.

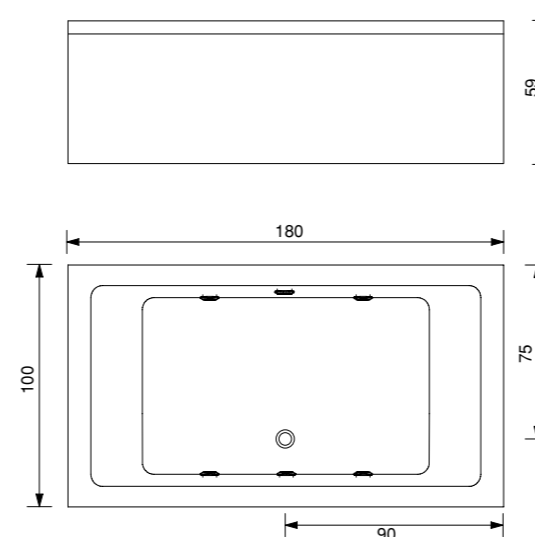
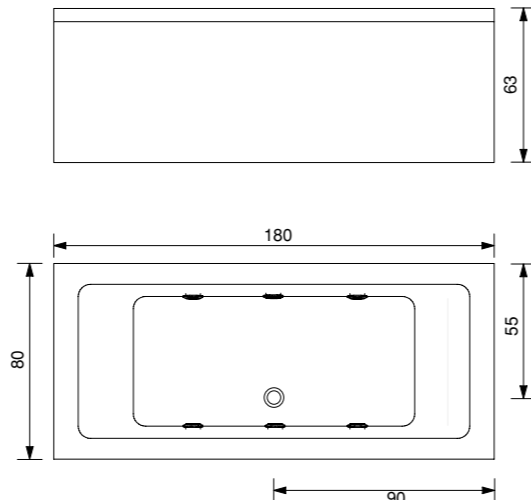
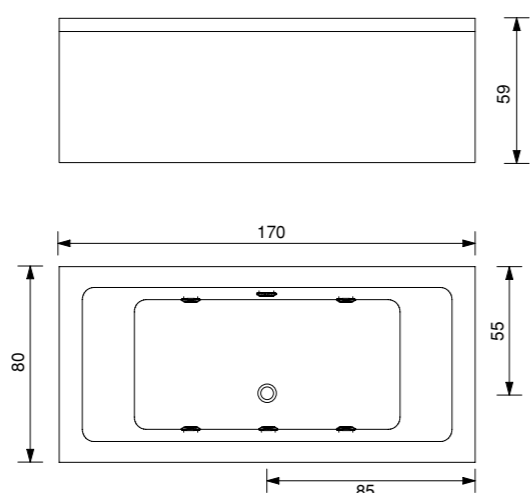
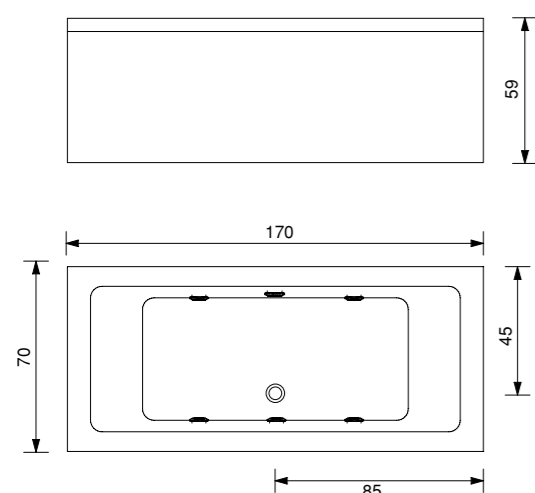

## DOTAZIONI E OPTIONAL

- CUSCINI POGGIATESTA
- IDROMASSAGGIO
- AIRPOOL
- SENSORE DI LIVELLO
- IMPIANTO DI DISINFEZIONE
- STABILIZZATORE TEMPERATURA ACQUA
- CROMOTERAPIA
- FARO
- RADIO
- INGRESSO AUDIO PER IPOD/CD
- OZONO TERAPIA
- RUBINETTERIA BORDO VASCA
- TELECOMANDO PER CONTROLLO FUNZIONI

## FOURNITURES ET OPTIONS

- COUSSINS REPOSE-TETE
- HYDROMASSAGE
- AIRPOOL
- CAPTEUR DE NIVEAU
- INSTALLATION DE DESINFECTION
- STABILISATEUR TEMPERATURE DE L'EAU
- CHROMOTHERAPIE
- SPOT
- RADIO
- ENTREE AUDIO POUR IPOD/CD
- OZONOTHERAPIE
- ROBINETTERIE REBORD DE BAIGNOIRE
- TELECOMMANDE POUR CONTROLE DES FONCTIONS

## FEATURES AND OPTIONALS

- HEADREST CUSHIONS
- HYDROMASSAGE
- AIRPOOL
- LEVEL SENSOR
- DISINFECTION SYSTEM
- WATER TEMPERATURE STABILIZER
- COLOR THERAPY
- SPOTLIGHT
- RADIO
- AUDIO INPUT FOR IPOD/CD
- OZONE THERAPY
- TUB EDGE FAUCETS
- REMOTE CONTROL FOR FUNCTIONS

## CARACTERÍSTICAS Y COMPLEMENTOS

- COJINES REPOSACABEZAS
- HIDROMASAJE
- AIRPOOL
- SENSOR DE NIVEL
- SISTEMA DE DESINFECCIÓN
- ESTABILIZADOR DE LA TEMPERATURA DEL AGUA
- CROMOTERAPIA
- LUZ
- RADIO
- ENTRADA DE AUDIO PARA IPOD/CD
- OZONOTERAPIA
- GRIFERÍA EN EL BORDE DE LA BAÑERA
- MANDO A DISTANCIA PARA CONTROL DE LAS FUNCIONES



## Quadra line

180 X 80 X 63h.

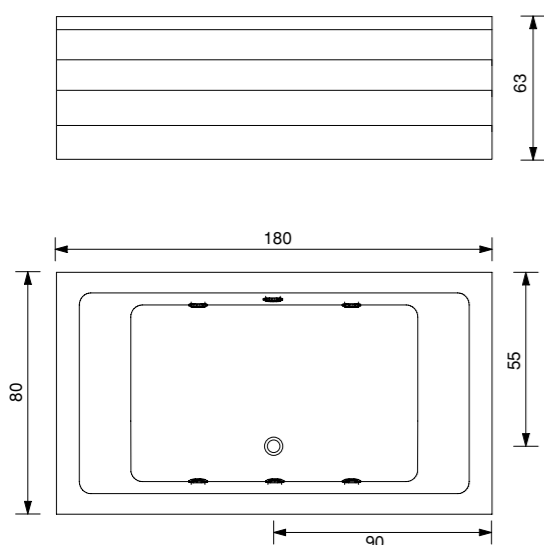

### DOTAZIONI E OPTIONAL

- CUSCINI POGGIATESTA
- PANNELLO ESTERNO CON FINITURE IN ACCIAIO LUCIDO/ORO
- IDROMASSAGGIO
- AIRPOOL
- SENSORE DI LIVELLO
- IMPIANTO DI DISINFEZIONE
- STABILIZZATORE TEMPERATURA ACQUA
- CROMOTERAPIA
- FARO
- RADIO
- INGRESSO AUDIO PER IPOD/CD
- OZONO TERAPIA
- RUBINETTERIA BORDO VASCA
- TELECOMANDO PER CONTROLLO FUNZIONI

### FOURNITURES ET OPTIONS

- COUSSINS REPOSE-TETE
- PANNEAU EXTERNE AVEC FINITIONS EN ACIER POLI/OR
- HYDROMASSAGE
- AIRPOOL
- CAPTEUR DE NIVEAU
- INSTALLATION DE DESINFECTION
- STABILISATEUR TEMPERATURE DE L'EAU
- CHROMOTHERAPIE
- SPOT
- RADIO
- ENTREE AUDIO POUR IPOD/CD
- OZONOTHERAPIE
- ROBINETTERIE REBORD DE BAIGNOIRE
- TELECOMMANDE POUR CONTROLE DES FONCTIONS

### FEATURES AND OPTIONALS

- HEADREST CUSHIONS
- OUTER PANEL WITH GLOSSY STEEL/GOLD FINISHES
- HYDROMASSAGE
- AIRPOOL
- LEVEL SENSOR
- DISINFECTION SYSTEM
- WATER TEMPERATURE STABILIZER
- COLOR THERAPY
- SPOTLIGHT
- RADIO
- AUDIO INPUT FOR IPOD/CD
- OZONE THERAPY
- TUB EDGE FAUCETS
- REMOTE CONTROL FOR FUNCTIONS

### CARACTERÍSTICAS Y COMPLEMENTOS

- COJINES REPOSACABEZAS
- PANEL EXTERIOR CON ACABADOS EN ACERO BRILLANTE/ORO
- HIDROMASAJE
- AIRPOOL
- SENSOR DE NIVEL
- SISTEMA DE DESINFECCIÓN
- ESTABILIZADOR DE LA TEMPERATURA DEL AGUA
- CROMOTERAPIA
- LUZ
- RADIO
- ENTRADA DE AUDIO PARA IPOD/CD
- OZONOTERAPIA
- GRIFERÍA EN EL BORDE DE LA BAÑERA
- MANDO A DISTANCIA PARA CONTROL DE LAS FUNCIONES



## Quadra box

170 X 70 X 215h. 170 X 80 X 215h. 180 X 80 X 219h.

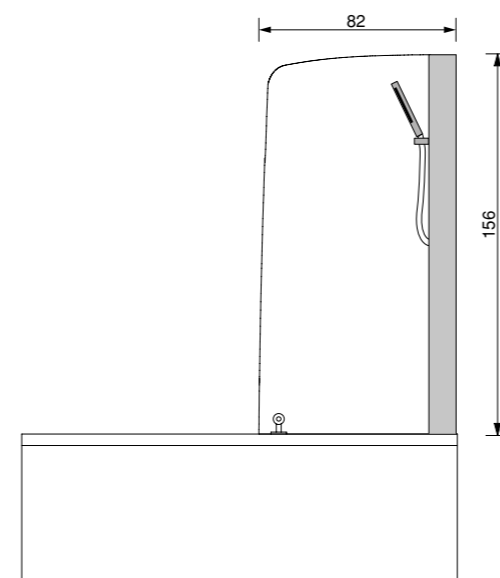

### DOTAZIONI E OPTIONAL

#### VASCA:

- CUSCINI POGGIATESTA
- IDROMASSAGGIO
- AIRPOOL
- SENSORE DI LIVELLO
- IMPIANTO DI DISINFEZIONE
- STABILIZZATORE TEMPERATURA ACQUA
- CROMOTERAPIA
- FARO
- RADIO
- INGRESSO AUDIO PER IPOD/CD
- OZONO TERAPIA
- RUBINETTERIA BORDO VASCA
- TELECOMANDO PER CONTROLLO FUNZIONI

#### BOX:

- CRISTALLO TEMPERATO DA 6 MM
- COLONNA SOPRAVASCA CON RUBINETTERIA
- DOCCETTA CON SUPPORTO SNODATO
- JET MASSAGGIO VERTICALE
- MENSOLA PORTA OGGETTI

### FOURNITURES ET OPTIONS

#### BAIGNOIRE:

- COUSSINS REPOSE-TETE
- HYDROMASSAGE
- AIRPOOL
- CAPTEUR DE NIVEAU
- INSTALLATION DE DESINFECTION
- STABILISATEUR TEMPERATURE DE L'EAU
- CHROMOTHERAPIE
- SPOT
- RADIO
- ENTREE AUDIO POUR IPOD/CD
- OZONOTHERAPIE
- ROBINETTERIE REBORD DE BAIGNOIRE
- TELECOMMANDE POUR CONTROLE DES FONCTIONS

#### CABINE:

- VERRE TREMPÉ DE 6 MM
- COLONNE AU-DESSUS DE LA BAIGNOIRE AVEC ROBINETTERIE
- DOUCHETTE AVEC SUPPORT ARTICULE
- JET DE MASSAGE VERTICAL
- ETAGERE PORTE-OBJETS

### FEATURES AND OPTIONALS

#### BATHTUB:

- HEADREST CUSHIONS
- HYDROMASSAGE
- AIRPOOL
- LEVEL SENSOR
- DISINFECTION SYSTEM
- WATER TEMPERATURE STABILIZER
- COLOR THERAPY
- SPOTLIGHT
- RADIO
- AUDIO INPUT FOR IPOD/CD
- OZONE THERAPY
- TUB EDGE FAUCETS
- REMOTE CONTROL FOR FUNCTIONS

#### CUBICLE:

- TEMPERED GLASS, 6 MM
- ABOVE-BATH COLUMN WITH FAUCETS
- FLEX HAND UNIT
- VERTICAL JET MASSAGE
- TOILETRY SHELF

### CARACTERÍSTICAS Y COMPLEMENTOS

#### BAÑERA:

- COJINES REPOSACABEZAS
- HIDROMASAJE
- AIRPOOL
- SENSOR DE NIVEL
- SISTEMA DE DESINFECCIÓN
- ESTABILIZADOR DE LA TEMPERATURA DEL AGUA
- CROMOTERAPIA
- LUZ
- RADIO
- ENTRADA DE AUDIO PARA IPOD/CD
- OZONOTERAPIA
- GRIFERÍA EN EL BORDE DE LA BAÑERA
- MANDO A DISTANCIA PARA CONTROL DE LAS FUNCIONES

#### CABINA:

- CRISTAL TEMPLADO DE 6 MM
- COLUMNA SOBRE LA BAÑERA CON GRIFERÍA
- ALCACHOFA CON SOPORTE ARTICULADO
- CHORRO MASAJE VERTICAL
- ESTANTE PORTAOBJETOS



## Quadra box easy

170 X 70 X 215h. 170 X 80 X 215h. 180 X 80 X 219h.

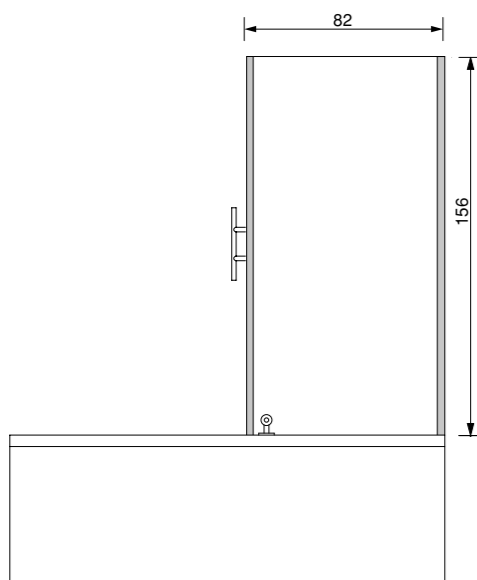

### DOTAZIONI E OPTIONAL

#### VASCA:

- CUSCINI POGGIATESTA
  - IDROMASSAGGIO
  - AIRPOOL
  - SENSORE DI LIVELLO
  - IMPIANTO DI DISINFEZIONE
  - STABILIZZATORE TEMPERATURA ACQUA
  - CROMOTERAPIA
  - FARO
  - RADIO
  - INGRESSO AUDIO PER IPOD/CD
  - OZONO TERAPIA
  - RUBINETTERIA BORDO VASCA
  - TELECOMANDO PER CONTROLLO FUNZIONI
- BOX:**
- CRISTALLO TEMPERATO DA 6 MM

### FOURNITURES ET OPTIONS

#### BAIGNOIRE:

- COUSSINS REPOSE-TETE
  - HYDROMASSAGE
  - AIRPOOL
  - CAPTEUR DE NIVEAU
  - INSTALLATION DE DESINFECTION
  - STABILISATEUR TEMPERATURE DE L'EAU
  - CHROMOTHERAPIE
  - SPOT
  - RADIO
  - ENTREE AUDIO POUR IPOD/CD
  - OZONOTHERAPIE
  - ROBINETTERIE REBORD DE BAIGNOIRE
  - TELECOMMANDE POUR CONTROLE DES FONCTIONS
- CABINE:**
- VERRE TREMPE DE 6 MM

### FEATURES AND OPTIONALS

#### BATHTUB:

- HEADREST CUSHIONS
  - HYDROMASSAGE
  - AIRPOOL
  - LEVEL SENSOR
  - DISINFECTION SYSTEM
  - WATER TEMPERATURE STABILIZER
  - COLOR THERAPY
  - SPOTLIGHT
  - RADIO
  - AUDIO INPUT FOR IPOD/CD
  - OZONE THERAPY
  - TUB EDGE FAUCETS
  - REMOTE CONTROL FOR FUNCTIONS
- CUBICLE:**
- TEMPERED GLASS, 6 MM

### CARACTERÍSTICAS Y COMPLEMENTOS

#### BAÑERA:

- COJINES REPOSACABEZAS
  - HIDROMASAJE
  - AIRPOOL
  - SENSOR DE NIVEL
  - SISTEMA DE DESINFECCIÓN
  - ESTABILIZADOR DE LA TEMPERATURA DEL AGUA
  - CROMOTERAPIA
  - LUZ
  - RADIO
  - ENTRADA DE AUDIO PARA IPOD/CD
  - OZONOTERAPIA
  - GRIFERÍA EN EL BORDE DE LA BAÑERA
  - MANDO A DISTANCIA PARA CONTROL DE LAS FUNCIONES
- CABINA:**
- CRISTAL TEMPLADO DE 6 MM



## Quadra box easy 2

170 X 70 X 215h. 170 X 80 X 215h. 180 X 80 X 219h.

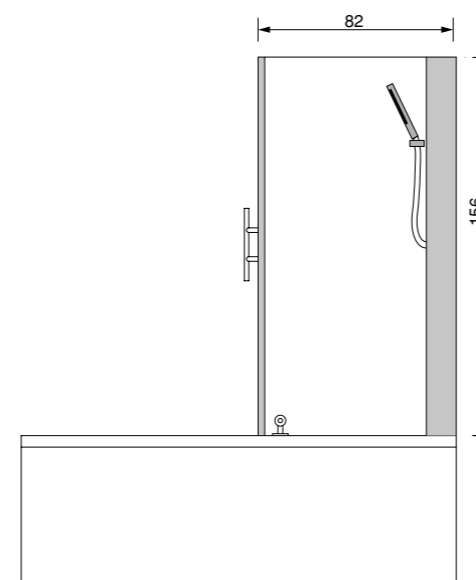

### DOTAZIONI E OPTIONAL

#### VASCA:

- CUSCINI POGGIATESTA
  - IDROMASSAGGIO
  - AIRPOOL
  - SENSORE DI LIVELLO
  - IMPIANTO DI DISINFEZIONE
  - STABILIZZATORE TEMPERATURA ACQUA
  - CROMOTERAPIA
  - FARO
  - RADIO
  - INGRESSO AUDIO PER IPOD/CD
  - OZONO TERAPIA
  - RUBINETTERIA BORDO VASCA
  - TELECOMANDO PER CONTROLLO FUNZIONI
- BOX:**
- CRISTALLO TEMPERATO DA 6 MM
  - COLONNA SOPRAVASCA CON RUBINETTERIA
  - DOCCETTA CON SUPPORTO SNODATO
  - JET MASSAGGIO VERTICALE
  - MENSOLA PORTA OGGETTI

### FOURNITURES ET OPTIONS

#### BAIGNOIRE:

- COUSSINS REPOSE-TETE
  - HYDROMASSAGE
  - AIRPOOL
  - CAPTEUR DE NIVEAU
  - INSTALLATION DE DESINFECTION
  - STABILISATEUR TEMPERATURE DE L'EAU
  - CHROMOTHERAPIE
  - SPOT
  - RADIO
  - ENTREE AUDIO POUR IPOD/CD
  - OZONOTHERAPIE
  - ROBINETTERIE REBORD DE BAIGNOIRE
  - TELECOMMANDE POUR CONTROLE DES FONCTIONS
- CABINE:**
- VERRE TREMPE DE 6 MM
  - COLONNE AU-DESSUS DE LA BAIGNOIRE AVEC ROBINETTERIE
  - DOUCHETTE AVEC SUPPORT ARTICULE
  - JET MASSAGE VERTICAL
  - ETAGERE PORTE-OBJETS

### FEATURES AND OPTIONALS

#### BATHTUB:

- HEADREST CUSHIONS
  - HYDROMASSAGE
  - AIRPOOL
  - LEVEL SENSOR
  - DISINFECTION SYSTEM
  - WATER TEMPERATURE STABILIZER
  - COLOR THERAPY
  - SPOTLIGHT
  - RADIO
  - AUDIO INPUT FOR IPOD/CD
  - OZONE THERAPY
  - TUB EDGE FAUCETS
  - REMOTE CONTROL FOR FUNCTIONS
- CUBICLE:**
- TEMPERED GLASS, 6 MM
  - ABOVE-BATH COLUMN WITH FAUCETS
  - FLEX HAND UNIT
  - VERTICAL MASSAGE JET
  - TOILETRY SHELF

### CARACTERÍSTICAS Y COMPLEMENTOS

#### BAÑERA:

- COJINES REPOSACABEZAS
  - HIDROMASAJE
  - AIRPOOL
  - SENSOR DE NIVEL
  - SISTEMA DE DESINFECCIÓN
  - ESTABILIZADOR DE LA TEMPERATURA DEL AGUA
  - CROMOTERAPIA
  - LUZ
  - RADIO
  - ENTRADA DE AUDIO PARA IPOD/CD
  - OZONOTERAPIA
  - GRIFERÍA EN EL BORDE DE LA BAÑERA
  - MANDO A DISTANCIA PARA CONTROL DE LAS FUNCIONES
- CABINA:**
- CRISTAL TEMPLADO DE 6 MM
  - COLUMNA SOBRE LA BAÑERA CON GRIFERÍA
  - ALCACHOFA CON SOPORTE ARTICULADO
  - CHORRO MASAJE VERTICAL
  - ESTANTE PORTAOBJETOS

# Spider

designer Fabrizio Batoni

180 X 80 X 68h.



tresse

HOME

VASCHE RETTANGOLARI  
RECTANGULAR BATHS

Spider  
167





Spider  
180 X 80 X 68h.

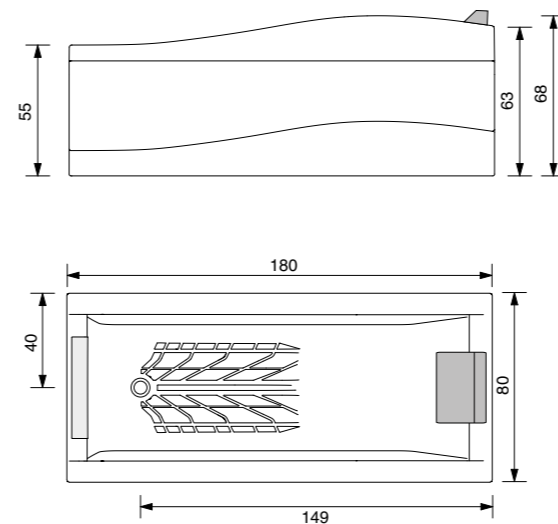

#### DOTAZIONI E OPTIONAL

- CUSCINO POGGIATESTA
- TROPPO PIENO A SKIMMER
- ANTISCIVOLO DESIGN "PNEUMATICO"
- SCARICO A PULSANTE
- IDROMASSAGGIO
- AIRPOOL
- SENSORE DI LIVELLO
- IMPIANTO DI DISINFEZIONE
- STABILIZZATORE TEMPERATURA ACQUA
- CROMOTERAPIA
- FARO
- RADIO
- INGRESSO AUDIO PER IPOD/CD
- OZONO TERAPIA
- RUBINETTERIA BORDO VASCA
- TELECOMANDO PER CONTROLLO FUNZIONI

#### FOURNITURES ET OPTIONS

- COUSSIN REPOSE-TETE
- TROP-PLEIN DE TYPE SKIMMER
- ANTIDERAPANT DESIGN "PNEUMATIQUE"
- EVACUATION A BOUTON
- HYDROMASSAGE
- AIRPOOL
- CAPTEUR DE NIVEAU
- INSTALLATION DE DESINFECTION
- STABILISATEUR TEMPERATURE DE L'EAU
- CHROMOTHERAPIE
- SPOT
- RADIO
- ENTREE AUDIO POUR IPOD/CD
- OZONOTHERAPIE
- ROBINETTERIE REBORD DE BAIGNOIRE
- TELECOMMANDE POUR CONTROLE DES FONCTIONS

#### FEATURES AND OPTIONALS

- HEADREST CUSHION
- OVERFLOW SKIMMER
- "TIRE-TRACK DESIGN" ANTI-SLIP
- BUTTON DRAIN
- HYDROMASSAGE
- AIRPOOL
- LEVEL SENSOR
- DISINFECTION SYSTEM
- WATER TEMPERATURE STABILIZER
- COLOR THERAPY
- SPOTLIGHT
- RADIO
- AUDIO INPUT FOR IPOD/CD
- OZONE THERAPY
- TUB EDGE FAUCETS
- REMOTE CONTROL FOR FUNCTIONS

#### CARACTERÍSTICAS Y COMPLEMENTOS

- COJÍN REPOSACABEZAS
- REBOSADERO SKIMMER
- ANTIDESLIZANTE DISEÑO "NEUMÁTICO"
- PULSADOR DE VACIADO
- HIDROMASAJE
- AIRPOOL
- SENSOR DE NIVEL
- SISTEMA DE DESINFECCIÓN
- ESTABILIZADOR DE LA TEMPERATURA DEL AGUA
- CROMOTERAPIA
- LUZ
- RADIO
- ENTRADA DE AUDIO PARA IPOD/CD
- OZONOTERAPIA
- GRIFERÍA EN EL BORDE DE LA BAÑERA
- MANDO A DISTANCIA PARA CONTROL DE LAS FUNCIONES

# Thesis

170 X 80 X 60h.



tresse

HOME

VASCHE RETTANGOLARI  
RECTANGULAR BATHTUBS

Thesis  
173





tresse

HOME

VASCHE RETTANGOLARI  
RECTANGULAR BATHS



# Thesis

170 X 80 X 60h.

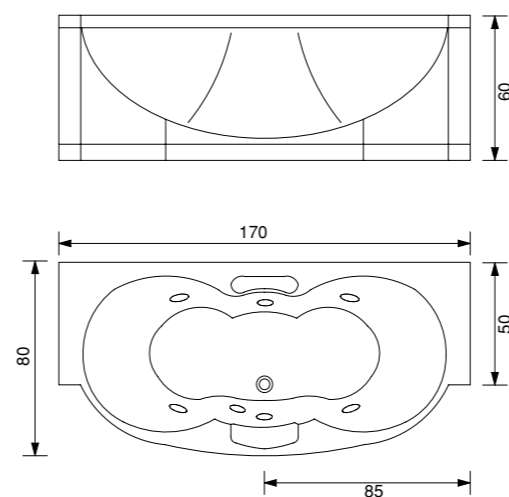

#### DOTAZIONI E OPTIONAL

- IDROMASSAGGIO
- AIRPOOL
- SENSORE DI LIVELLO
- IMPIANTO DI DISINFEZIONE
- STABILIZZATORE TEMPERATURA ACQUA
- CROMOTERAPIA
- FARO
- RADIO
- INGRESSO AUDIO PER IPOD/CD
- OZONO TERAPIA
- RUBINETTERIA BORDO VASCA
- TELECOMANDO PER CONTROLLO FUNZIONI

#### FOURNITURES ET OPTIONS

- HYDROMASSAGE
- AIRPOOL
- CAPTEUR DE NIVEAU
- INSTALLATION DE DESINFECTION
- STABILISATEUR TEMPERATURE DE L'EAU
- CHROMOTHERAPIE
- SPOT
- RADIO
- ENTREE AUDIO POUR IPOD/CD
- OZONOTHERAPIE
- ROBINETTERIE REBORD DE BAIGNOIRE
- TELECOMMANDE POUR CONTROLE DES FONCTIONS

#### FEATURES AND OPTIONALS

- HYDROMASSAGE
- AIRPOOL
- LEVEL SENSOR
- DISINFECTION SYSTEM
- WATER TEMPERATURE STABILIZER
- COLOR THERAPY
- SPOTLIGHT
- RADIO
- AUDIO INPUT FOR IPOD/CD
- OZONE THERAPY
- TUB EDGE FAUCETS
- REMOTE CONTROL FOR FUNCTIONS

#### CARACTERÍSTICAS Y COMPLEMENTOS

- HIDROMASAJE
- AIRPOOL
- SENSOR DE NIVEL
- SISTEMA DE DESINFECCIÓN
- ESTABILIZADOR DE LA TEMPERATURA DEL AGUA
- CROMOTERAPIA
- LUZ
- RADIO
- ENTRADA DE AUDIO PARA IPOD/CD
- OZONOTERAPIA
- GRIFERÍA EN EL BORDE DE LA BAÑERA
- MANDO A DISTANCIA PARA CONTROL DE LAS FUNCIONES

# Vision

designer Paolo Parea

180 X 80 X 60h.



tresse

HOME

VASCHE RETTANGOLARI  
RECTANGULAR BATHS

Vision  
179

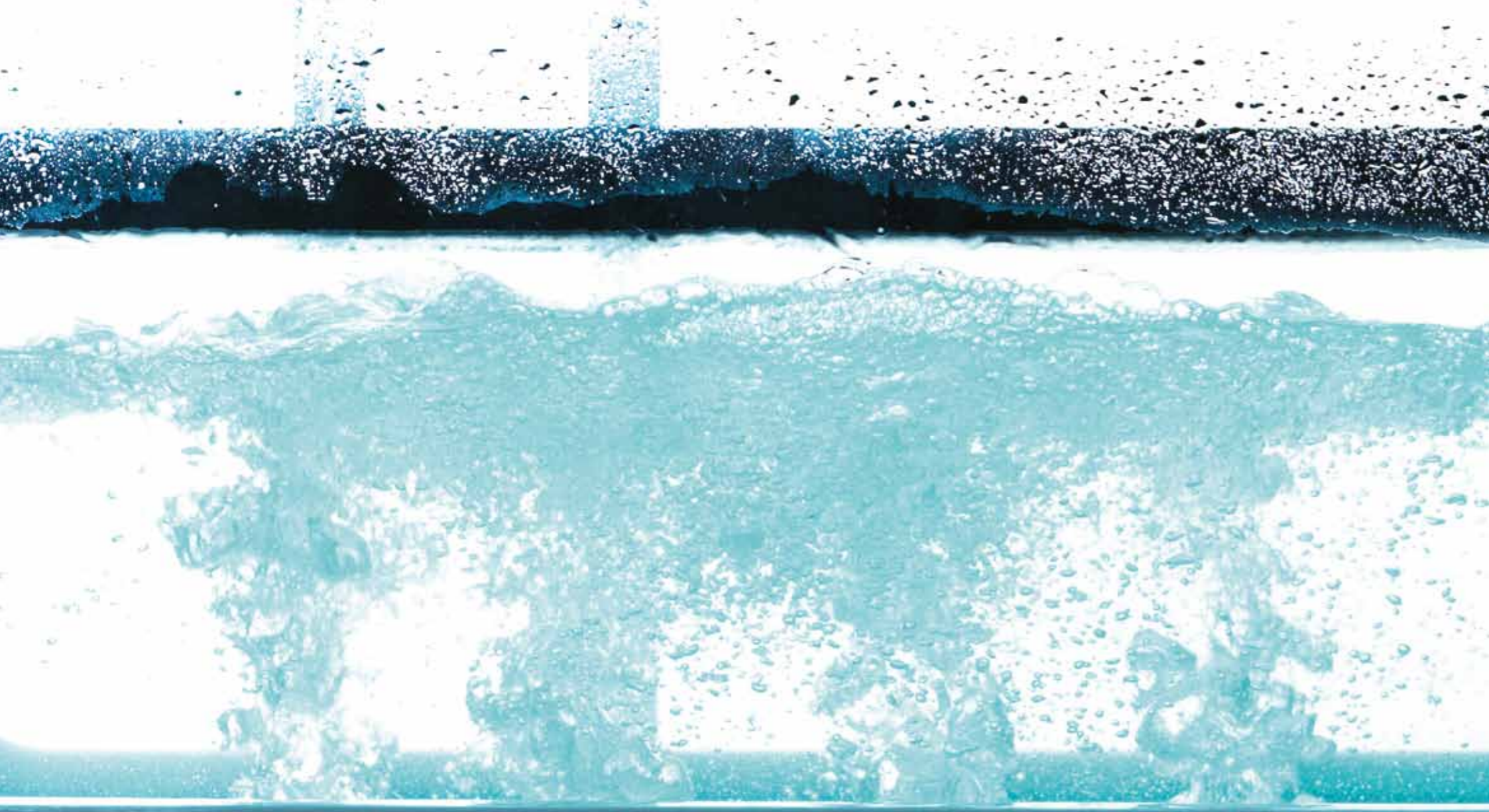

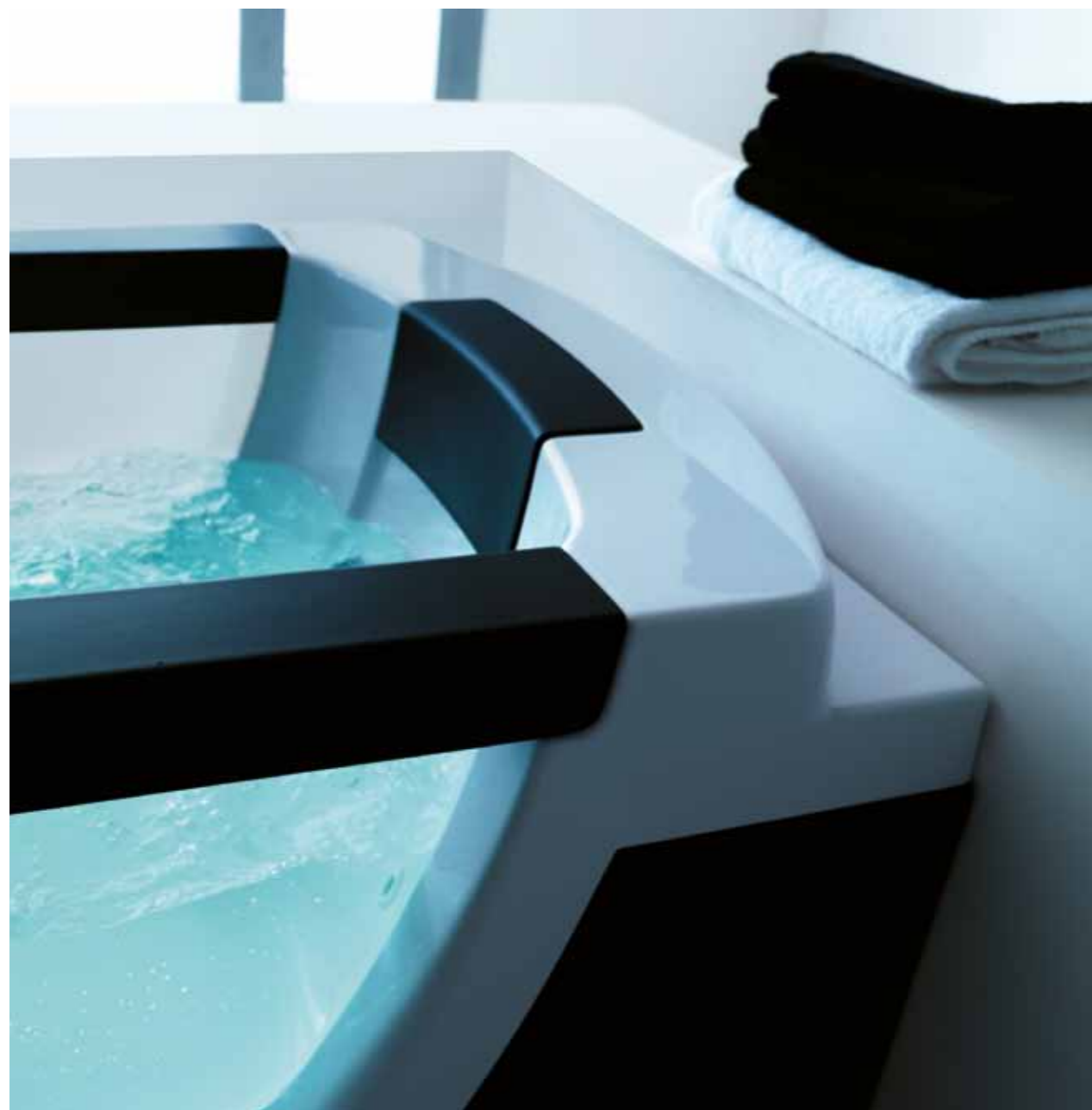



# Vision

180 X 80 X 60h.

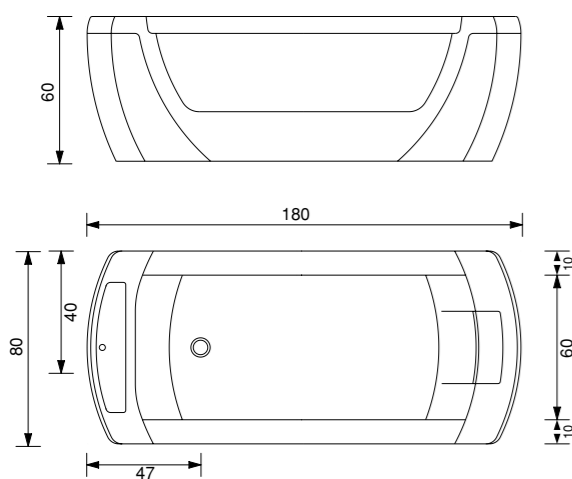

## DOTAZIONI E OPTIONAL

- BRACCIOLI E POGGIATESTA INTEGRATI
- PARETI LATERALI IN CRISTALLO VISARM
- VANO CON SPORTELLO
- SCARICO A PULSANTE
- IDROMASSAGGIO
- AIRPOOL
- SENSORE DI LIVELLO
- IMPIANTO DI DISINFEZIONE
- STABILIZZATORE TEMPERATURA ACQUA
- CROMOTERAPIA
- FARO
- RADIO
- INGRESSO AUDIO PER IPOD/CD
- OZONO TERAPIA
- RUBINETTERIA BORDO VASCA
- TELECOMANDO PER CONTROLLO FUNZIONI

## FOURNITURES ET OPTIONS

- ACCOUDOIRS ET REPOSE-TETE INTEGRÉS
- PAROIS LATÉRALES EN VERRE STRATIFIÉ INCASSABLE
- COMPARTIMENT AVEC PORTE
- ÉVACUATION À BOUTON
- HYDROMASSAGE
- AIRPOOL
- CAPTEUR DE NIVEAU
- INSTALLATION DE DESINFECTION
- STABILISATEUR TEMPERATURE DE L'EAU
- CHROMOTHERAPIE
- SPOT
- RADIO
- ENTRÉE AUDIO POUR IPOD/CD
- OZONOTHERAPIE
- ROBINETTERIE REBORD DE BAIGNOIRE
- TELECOMMANDE POUR CONTRÔLE DES FONCTIONS

## FEATURES AND OPTIONALS

- BUILT-IN ARM AND HEADREST
- SIDE WALLS IN LAMINATED SAFETY GLASS
- COMPARTMENT WITH HATCH
- BUTTON DRAIN
- HYDROMASSAGE
- AIRPOOL
- LEVEL SENSOR
- DISINFECTION SYSTEM
- WATER TEMPERATURE STABILIZER
- COLOR THERAPY
- SPOTLIGHT
- RADIO
- AUDIO INPUT FOR IPOD/CD
- OZONE THERAPY
- TUB EDGE FAUCETS
- REMOTE CONTROL FOR FUNCTIONS

## CARACTERÍSTICAS Y COMPLEMENTOS

- REPOSABRAZOS Y REPOSACABEZAS INTEGRADOS
- PAREDES LATERALES DE CRISTAL ESTRATIFICADO IRROMPIBLE
- COMPARTIMENTO CON PUERTA
- PULSADOR DE VACIADO
- HIDROMASAJE
- AIRPOOL
- SENSOR DE NIVEL
- SISTEMA DE DESINFECCIÓN
- ESTABILIZADOR DE LA TEMPERATURA DEL AGUA
- CROMOTERAPIA
- LUZ
- RADIO
- ENTRADA DE AUDIO PARA IPOD/CD
- OZONOTERAPIA
- GRIFERÍA EN EL BORDE DE LA BAÑERA
- MANDO A DISTANCIA PARA CONTROL DE LAS FUNCIONES

## CENTROSTANZA

FREESTANDING  
CENTRE DE PIÈCE  
INDEPENDIENTE  
180 X 80 X 60h.



## A PARETE

WALL  
À PAROI  
DE PARED  
180 X 80 X 60h.



## ANGOLARE DX/SX

LEFT/RIGHT CORNER  
ANGULAIRE DR/GAU  
ANGULAR DCHA/IZQ  
183 X 80 X 60h.



## A NICCHIA

RECESSED NICHE  
À NICHE  
EMPOTRADA  
185 X 80 X 60h.



*Calypso*  
183 X 70 X 79h.

*Crystal*  
180 X 80 X 64h.

*Epoca*  
170 X 80 X 72h.

*Epoca egg*  
176 X 84 X 75h.

*Epoca one top*  
170 X 80/105 X 72h.

*Gen-x*  
130 X 75 X 95/105h.

*Milo*  
200 X 78 X 87h.

*Moulin*  
135 X 80 X 102h.

*Niña*  
170 X 80 X 75h.

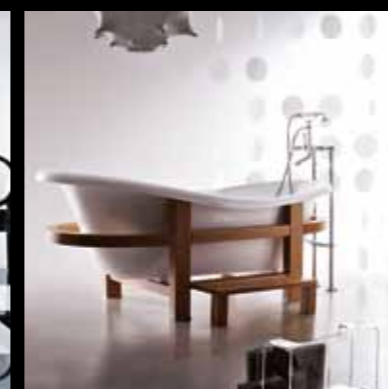

# Calypso

designer Alessandro Lenarda

183 X 70 X 79h.



tresse

HOME

VASCHE SPECIALI  
SPECIAL BATHUBS

Calypso  
189





Calypso  
183 X 70 X 79h.

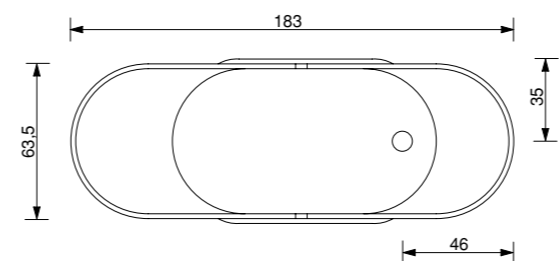
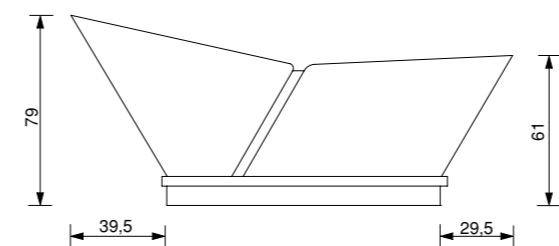

**DOTAZIONI E OPTIONAL**

- VASCA REALIZZATA IN MULTISTRATO MARINO
- FINITURA CILIEGIO O WENGE'
- SCARICO A PULSANTE

**FOURNITURES ET OPTIONS**

- BAIGNOIRE REALISEE EN MULTICOUCHE MARIN
- FINITION MERISIER OU WENGE
- EVACUATION A BOUTON

**FEATURES AND OPTIONALS**

- TUB BUILT WITH MARINE PLYWOOD
- CHERRY OR WENGE FINISH
- BUTTON DRAIN

**CARACTERÍSTICAS Y COMPLEMENTOS**

- BAÑERA REALIZADA EN MULTISTRATO MARINO
- ACABADO EN CEREZO O WENGUÉ
- PULSADOR DE VACIADO



# Crystal

designer Paolo Parea

180 X 80 X 64h.





# Crystal

180 X 80 X 64h.

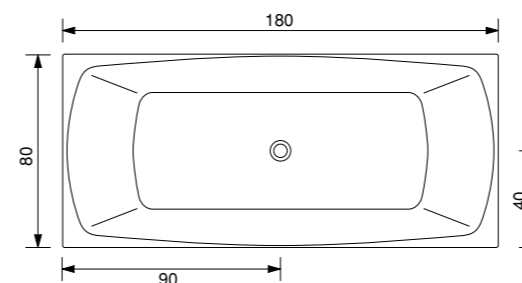
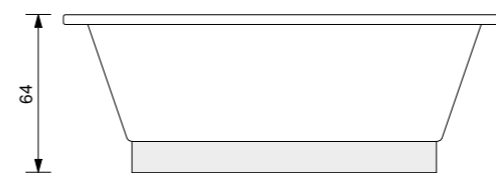

#### DOTAZIONI E OPTIONAL

- POGGIATESTA IN SKY ARGENTO
- BASAMENTO IN LAMINATO ACRILICO A SPECCHIO
- SCARICO A PULSANTE

#### FOURNITURES ET OPTIONS

- REPOSE-TETE EN SIMILI CUIR ARGENT
- SOCLE EN LAMINE ACRYLIQUE BRILLANT
- EVACUATION A BOUTON

#### FEATURES AND OPTIONALS

- SILVER FAUX LEATHER HEADREST
- BASE OF REFLECTIVE ACRYLIC LAMINATE
- BUTTON DRAIN

#### CARACTERÍSTICAS Y COMPLEMENTOS

- REPOSACABEZAS DE POLIPIEL PLATEADO
- ESTRUCTURA DE LAMINADO ACRÍLICO EFECTO ESPEJO
- PULSADOR DE VACIADO

# Epoca

170 X 80 X 72h.



tresse

HOME

VASCHE SPECIALI  
SPECIAL BATHTUBS

Epoca  
199



# Epoca impero

designer Anika Elisabetta Luceri

170 X 80 X 72h.



tresse

HOME

VASCHE SPECIALI  
SPECIAL BATHTUBS

Epoca impero  
203



Epoca  
170 X 80 X 72h.

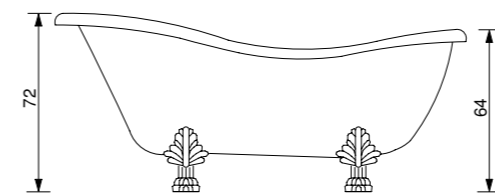

**DOTAZIONI E OPTIONAL**

- PIEDI IN METALLO IN STILE CLASSICO
- COLONNA DI SCARICO CON SIFONE A VISTA
- RUBINETTERIA IN STILE
- FINITURE COLONNA E PIEDI: BIANCO, CROMO, ORO E BRONZO
- DECORI PERSONALIZZATI

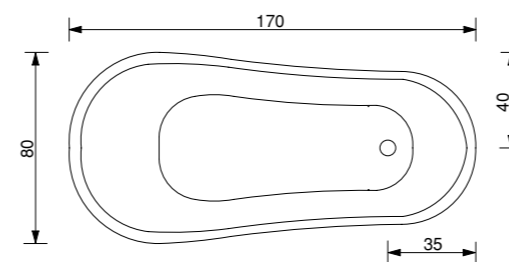

**FOURNITURES ET OPTIONS**

- PIEDS EN METAL STYLE CLASSIQUE
- COLONNE D'EVACUATION AVEC SIPHON VISIBLE
- ROBINETTERIE STYLE CLASSIQUE
- FINITION COLONNE ET PIEDS: BLANC, CHROME, OR ET BRONZE
- DECORS PERSONNALISES

**FEATURES AND OPTIONALS**

- METAL FEET IN CLASSIC STYLE
- DRAIN COLUMN WITH VISIBLE TRAP
- CLASSIC-STYLE FAUCETS
- COLUMN AND FEET FINISH: WHITE, CHROME, GOLD AND BRONZE
- CUSTOM DECORATIONS

**CARACTERÍSTICAS Y COMPLEMENTOS**

- PIES DE METAL ESTILO CLÁSICO
- COLUMNA DE DESAGÜE CON SIFÓN A LA VISTA
- GRIFERÍA DE ESTILO CLÁSICO
- ACABADOS COLUMNA Y PIES: BLANCO, CROMO, ORO Y BRONCE
- DECORACIÓN PERSONALIZADA



tresse

HOME



# Epoca egg

designer Paolo Parea

176 X 84 X 75h.

Epoca egg  
207

VASCHE SPECIALI  
SPECIAL BATHTUBS









## Epoca egg

176 X 84 X 75h.

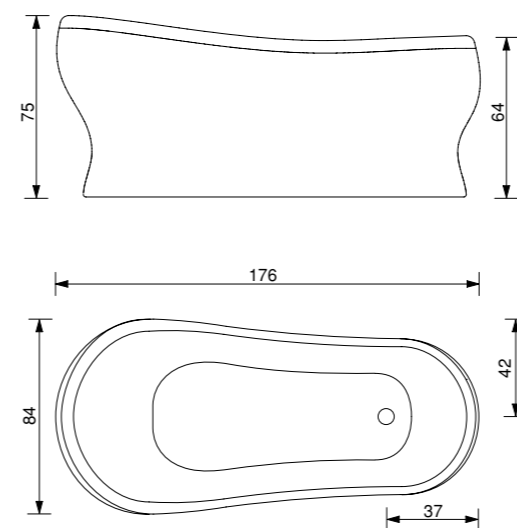

### DOTAZIONI E OPTIONAL

- PANNELLO ESTERNO UNICO PEZZO
- IDROMASSAGGIO
- AIRPOOL
- SENSORE DI LIVELLO
- STABILIZZATORE TEMPERATURA ACQUA
- CROMOTERAPIA
- FARO
- RADIO
- RUBINETTERIA IN STILE
- DECORI PERSONALIZZATI

### FOURNITURES ET OPTIONS

- PANNEAU EXTERNE D'UNE SEULE PIECE
- HYDROMASSAGE
- AIRPOOL
- CAPTEUR DE NIVEAU
- STABILISATEUR TEMPERATURE DE L'EAU
- CHROMOTHERAPIE
- SPOT
- RADIO
- RUBINETTERIE STYLE CLASSIQUE
- DECORS PERSONNALISES

### FEATURES AND OPTIONALS

- ONE PIECE OUTER PANEL
- HYDROMASSAGE
- AIRPOOL
- LEVEL SENSOR
- WATER TEMPERATURE STABILIZER
- COLOR THERAPY
- SPOTLIGHT
- RADIO
- CLASSIC-STYLE FAUCETS
- CUSTOM DECORATIONS

### CARACTERÍSTICAS Y COMPLEMENTOS

- PANEL EXTERIOR DE UNA PIEZA
- HIDROMASAJE
- AIRPOOL
- SENSOR DE NIVEL
- ESTABILIZADOR DE LA TEMPERATURA DEL AGUA
- CROMOTERAPIA
- LUZ
- RADIO
- GRIFERÍA DE ESTILO CLÁSICO
- DECORACIÓN PERSONALIZADA



# Epoca one top

designer Paolo Parea

170 X 80/105 X 72h.



tresse

HOME

VASCHE SPECIALI  
SPECIAL BATHUBS

Epoca one top  
217



## Epoca one top

170 X 80/105 X 72h.

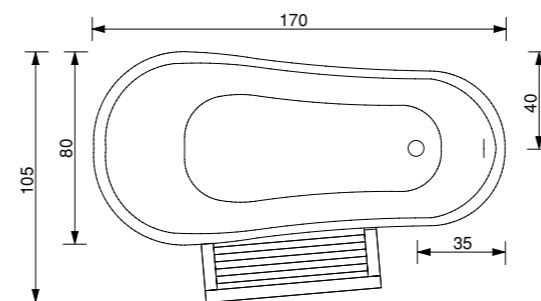
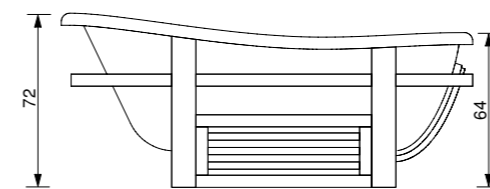

### DOTAZIONI E OPTIONAL

- STRUTTURA IN LEGNO MASSELLO CON FINITURE ROVERE/WENGE'
- GRADINO RIBALTABILE INTEGRATO
- COLONNA DI SCARICO CON SIFONE A VISTA
- RUBINETTERIA IN STILE
- FINITURE COLONNA: BIANCO, CROMO, ORO E BRONZO

### FOURNITURES ET OPTIONS

- STRUCTURE EN BOIS MASSIF AVEC FINITIONS CHENE/WENGE
- MARCHE BASCULANTE INTEGREE
- COLONNE D'EVACUATION AVEC SIPHON VISIBLE
- ROBINETTERIE STYLE CLASSIQUE
- FINITION COLONNE: BLANC, CHROME, OR ET BRONZE

### FEATURES AND OPTIONALS

- SOLID WOOD STRUCTURE WITH OAK OR WENGE FINISH
- BUILT-IN FOLDING STEP
- DRAIN COLUMN WITH VISIBLE TRAP
- CLASSIC-STYLE FAUCETS
- COLUMN FINISHES: WHITE, CHROME, GOLD AND BRONZE

### CARACTERÍSTICAS Y COMPLEMENTOS

- ESTRUCTURA DE MADERA MACIZA CON ACABADOS EN ROBLE O WENGUÉ
- ESCALÓN BASCULANTE INTEGRADO
- COLUMNA DE DESAGÜE CON SIFÓN A LA VISTA
- GRIFERÍA DE ESTILO CLÁSICO
- ACABADOS COLUMNA: BLANCO, CROMO, ORO Y BRONCE

Gen-x

designer Paolo Parea

130 X 75 X 95/105h.



tresse

HOME

VASCHE SPECIALI  
SPECIAL BATHUBS

Gen-x  
221



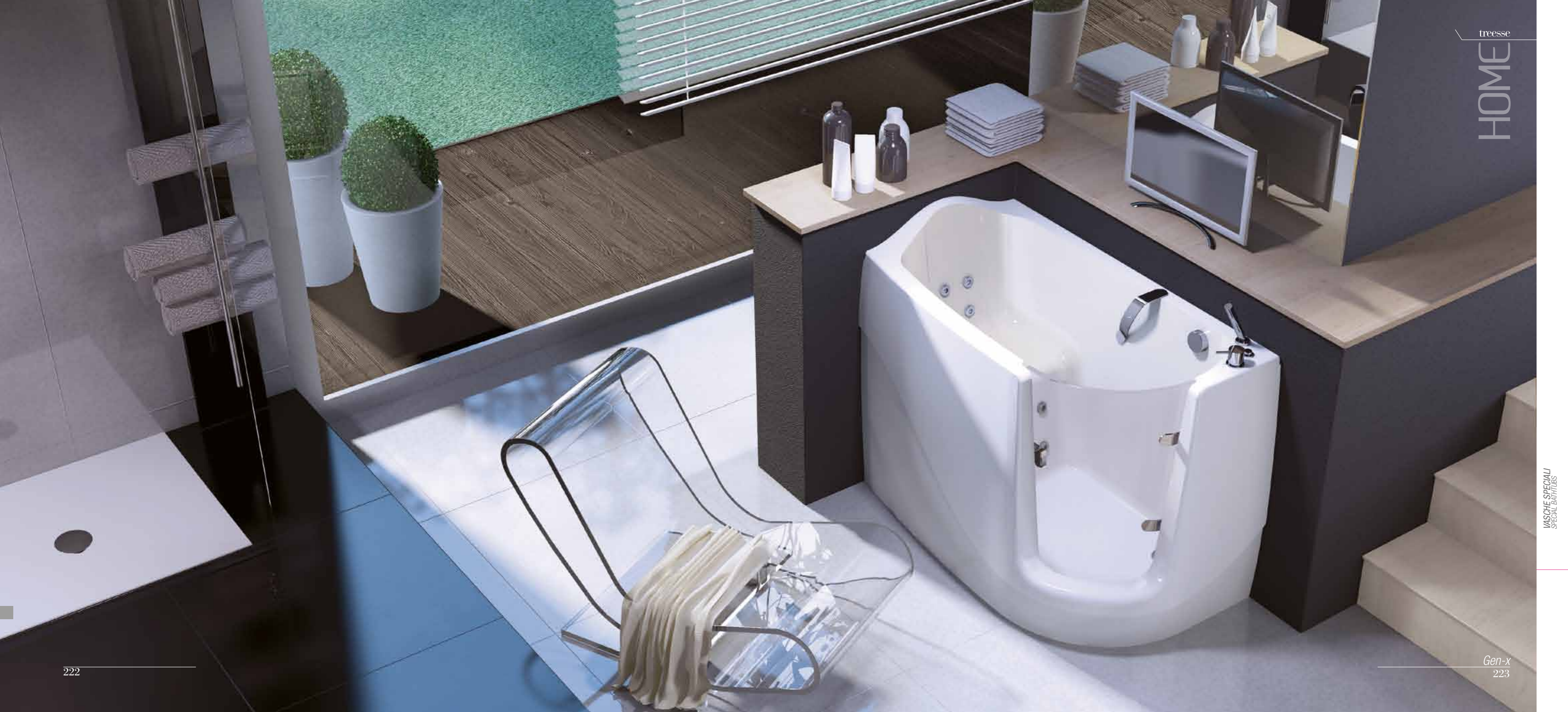

SPORTELLO  
DOOR  
PORTE  
PUERTA



Agevolazione nell'accesso.  
Chiusura interna utilizzata come supporto per appoggiarsi o tirarsi in piedi.

Easier access.  
Internal door used as support to lean on or pull up to standing.

Accès facilité.  
Fermeture interne utilisée comme support pour s'adosser ou se relever.

Facilidad de acceso.  
Cierre interior utilizado como soporte para apoyarse o ponerse de pie.

SCALINO  
STEP  
MARCHE  
ESCALÓN

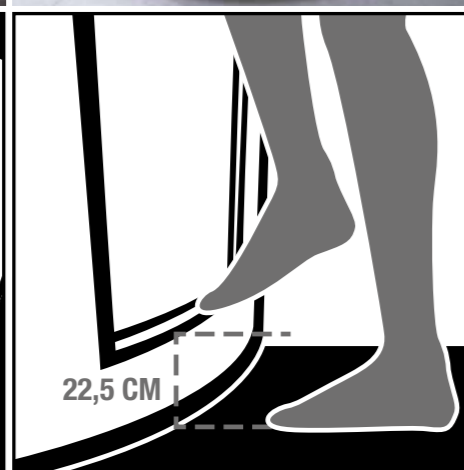

Altezza ottimale per facilitare l'accesso.  
Linea arrotondata che non crea ostacoli.  
Spessore del piano che agevola l'appoggio del piede.

Optimum height for easy access.  
Rounded lines avoid creating obstacles.  
The surface's depth facilitates foot support.

Hauteur optimale pour faciliter l'accès.  
Ligne arrondie ne créant pas d'obstacles.  
Épaisseur du plan qui facilite l'appui du pied.

Altura óptima para facilitar el acceso.  
De líneas redondeadas para no crear obstáculos. Espesor de la superficie que facilita el apoyo del pie.

SEDUTA ERGONOMICA  
ERGONOMIC SEAT  
ASSISE ERGONOMIQUE  
ASIENTO ERGONÓMICO

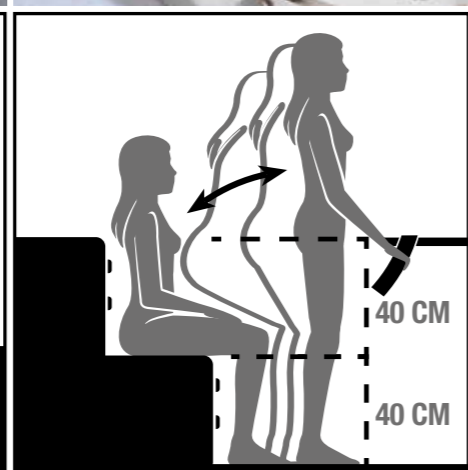

Seduta ergonomica con getti dorsali incassati.  
Piano di seduta inclinato per agevolare la persona nel mettersi in piedi.

Ergonomic seat with built-in back massage jets.  
Inclined seat surface to facilitate standing up.

Assise ergonomique avec jets dorsaux encastrés.  
Plan d'assise incliné pour faciliter le redressement.

Asiento ergonómico con chorros dorsales encastrados.  
Superficie de asiento inclinada para facilitar el ponerse de pie.

IDROMASSAGGIO  
HYDROMASSAGE  
HYDROMASSAGE  
HIDROMASAJE

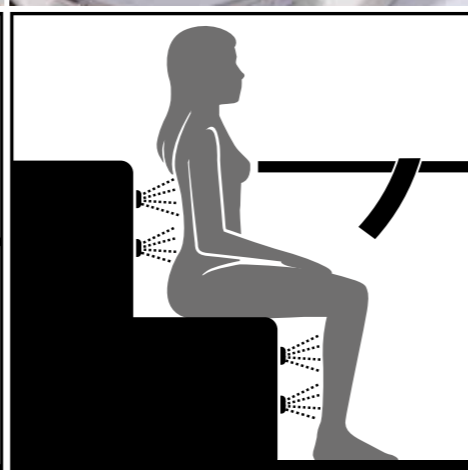

Posizione ideale nella zona lombare e nella zona piedi-polpaccio.  
Effetto massaggiante e drenante di elevata efficacia.

Perfectly placed for lower back and calf-foot areas.  
Highly effective draining massage.

Position idéale dans la zone lombaire et dans la zone pieds-mollet.  
Effet massant et drainant très efficace.

Posición ideal de la zona lumbar y de la zona de los pies y las pantorrillas.  
Efecto masaje y drenante de elevada eficacia.



Il nuovo impianto e' un elemento fortemente innovativo all'interno del prodotto.  
Effettuata l'attivazione, lo scarico forzato della vasca si raggiunge in un tempo assolutamente breve pari ad 1 minuto e 30 secondi.  
Il funzionamento avviene in modo automatico, ovvero in parallelo all'attivazione del normale impianto di scarico a gravita' senza necessita' di comandi aggiuntivi.

The new system is a highly innovative feature inside the tub.  
After being activated, the forced draining of the tub is completed very quickly, in 1 minute and 30 seconds.  
The operation is automatic, in tandem with the activation of regular gravity-based draining, without requiring extra controls.

La nouvelle installation est un élément fortement innovant à l'intérieur du produit, après l'activation, le vidage forcé de la baignoire s'effectue très rapidement en 1 minute et 30 secondes.  
Le fonctionnement est automatique, c'est-à-dire parallèle à l'activation de l'installation normale d'évacuation par gravité, sans exiger de commandes supplémentaires.

La nueva instalación es un elemento muy innovador en el conjunto del producto. Una vez activado, el vaciado forzado de la bañera se produce en un tiempo absolutamente breve de 1 minuto y 30 segundos.  
El funcionamiento tiene lugar de forma automática, paralelamente a la activación del sistema normal de vaciado por gravedad, sin necesidad de mandos adicionales.



# Gen-x

130 X 75 X 95/105h.

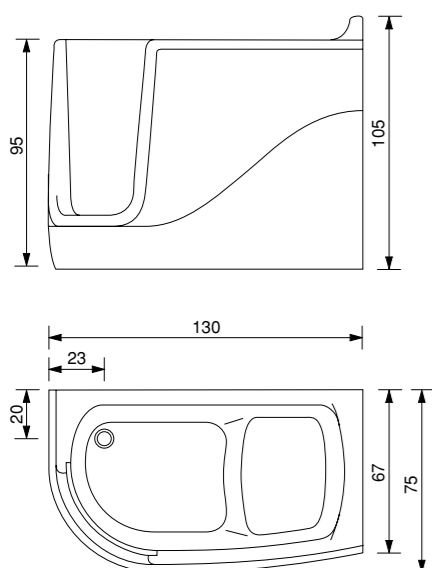

## DOTAZIONI E OPTIONAL

- ACCESSO FACILITATO CON PORTA IN METACRILATO
- GRADINO DI ENTRATA RIBASSATO
- IMPIANTO PER SVUOTAMENTO RAPIDO
- MANIGLIA DI SOSTEGNO
- JET DORSALI INCASSATI
- IDROMASSAGGIO
- AIRPOOL
- SENSORE DI LIVELLO
- IMPIANTO DI DISINFEZIONE
- STABILIZZATORE TEMPERATURA ACQUA
- CROMOTERAPIA
- FARO
- RADIO
- INGRESSO AUDIO PER IPOD/CD
- OZONO TERAPIA
- RUBINETTERIA BORDO VASCA
- TELECOMANDO PER CONTROLLO FUNZIONI

## FOURNITURES ET OPTIONS

- ACCES FACILITE AVEC PORTE EN METHACRYLATE
- MARCHE D'ENTREE ABAISSEE
- INSTALLATION POUR VIDAGE RAPIDE
- POIGNEE DE SOUTIEN
- JET DORSAUX ENCASTRES
- HYDROMASSAGE
- AIRPOOL
- CAPTEUR DE NIVEAU
- INSTALLATION DE DESINFECTION
- STABILISATEUR TEMPERATURE DE L'EAU
- CHROMOTHERAPIE
- SPOT
- RADIO
- ENTREE AUDIO POUR IPOD/CD
- OZONOTHERAPIE
- ROBINETTERIE REBORD DE BAIGNOIRE
- TELECOMMANDE POUR CONTROLE DES FONCTIONS

## FEATURES AND OPTIONALS

- EASY ACCESS WITH METHACRYLATE DOOR
- LOWERED ENTRY STEP
- RAPID DRAINAGE SYSTEM
- GRAB BAR
- FLUSH BACK MASSAGE JETS
- HYDROMASSAGE
- AIRPOOL
- LEVEL SENSOR
- DISINFECTION SYSTEM
- WATER TEMPERATURE STABILIZER
- COLOR THERAPY
- SPOTLIGHT
- RADIO
- AUDIO INPUT FOR IPOD/CD
- OZONE THERAPY
- TUB EDGE FAUCETS
- REMOTE CONTROL FOR FUNCTIONS

## CARACTERÍSTICAS Y COMPLEMENTOS

- ACCESO FACILITADO CON PUERTA DE METACRILATO
- ESCALÓN DE ENTRADA REBAJADO
- SISTEMA DE VACIADO RÁPIDO
- ASIDERO DE APOYO
- CHORROS DORSALES ENCASTRADOS
- HIDROMASAJE
- AIRPOOL
- SENSOR DE NIVEL
- SISTEMA DE DESINFECCIÓN
- ESTABILIZADOR DE LA TEMPERATURA DEL AGUA
- CROMOTERAPIA
- LUZ
- RADIO
- ENTRADA DE AUDIO PARA IPOD/CD
- OZONOTERAPIA
- GRIFERÍA EN EL BORDE DE LA BAÑERA
- MANDO A DISTANCIA PARA CONTROL DE LAS FUNCIONES

INSTALLAZIONE AD ANGOLO SX  
LEFT CORNER INSTALLATION  
INSTALLATION ANGULAIRE GAU  
INSTALACIÓN EN ÁNGULO IZQUIERDO



INSTALLAZIONE AD ANGOLO DX  
RIGHT CORNER INSTALLATION  
INSTALLATION ANGULAIRE DR  
INSTALACIÓN EN ÁNGULO DERECHO





tresse

HOME



VASCHE SPECIALI  
SPECIAL BATHUBS

Milo

designer Alessandro Lenarda

200 X 78 X 87h.

Milo  
229





Milo  
200 X 78 X 87h.

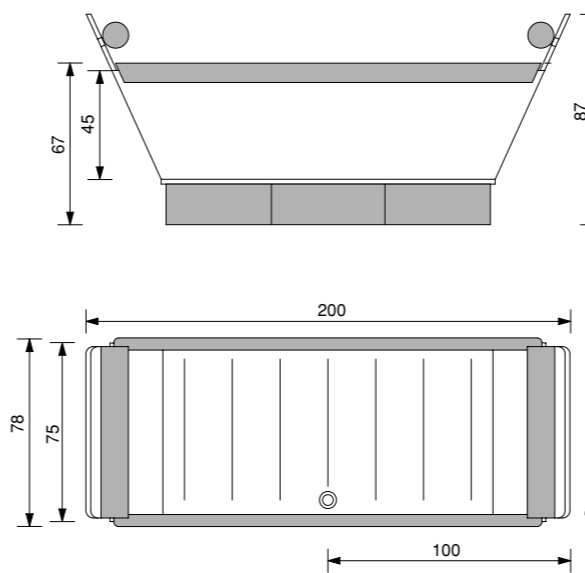

**DOTAZIONI E OPTIONAL**

- PARETI LATERALI IN CRISTALLO VISARM
- FONDO VASCA IN CRISTALLO VISARM
- DOPPIA SEDUTA INTERNA
- CUSCINI POGGIATESTA
- BRACCIOLI
- BASAMENTO CON CASSETTO
- FINITURE:  
CUOIO, BIANCO, NERO E ROSSO

**FOURNITURES ET OPTIONS**

- PAROIS LATÉRALES EN VERRE STRATIFIÉ INCASSABLE
- FOND BAIGNOIRE EN VERRE STRATIFIÉ INCASSABLE
- DOUBLE ASSISE INTERNE
- COUSSINS REPOSE-TÊTE
- ACCOUDOIRS
- SOCLE AVEC TIROIR
- FINITIONS :  
CUIR, BLANC, NOIR ET ROUGE

**FEATURES AND OPTIONALS**

- SIDE WALLS IN LAMINATED SAFETY GLASS
- TUB BOTTOM IN LAMINATED SAFETY GLASS
- INTERNAL TWIN SEATS
- HEADREST CUSHIONS
- ARMRESTS
- BASE WITH DRAWER
- FINISHES:  
LEATHER, WHITE, BLACK AND RED

**CARACTERÍSTICAS Y COMPLEMENTOS**

- PAREDES LATÉRALES DE CRISTAL ESTRATIFICADO IRROMPIBLE
- FONDO BAÑERA DE CRISTAL ESTRATIFICADO IRROMPIBLE
- DOBLE ASIENTO INTERIOR
- COJINES REPOSACABEZAS
- REPOSABRAZOS
- BASE CON CAJÓN
- ACABADOS:  
CUERO, BLANCO, NEGRO Y ROJO



# Moulin

designer Alessandro Lenarda

135 X 80 X 102h.

Moulin  
235



## Moulin

135 X 80 X 102h.

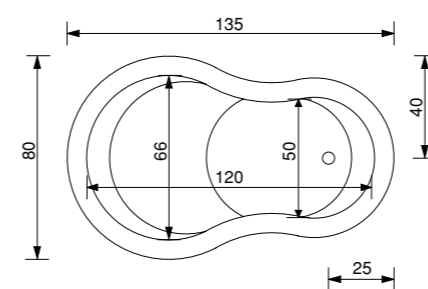
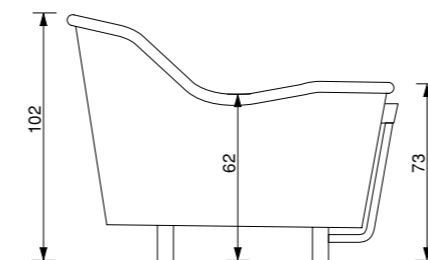

### DOTAZIONI E OPTIONAL

- PIEDI IN METALLO IN STILE CLASSICO
- COLONNA DI SCARICO CON SIFONE A VISTA
- RUBINETTERIA IN STILE
- FINITURE COLONNA E PIEDI: CROMO, ORO E BRONZO
- DECORI PERSONALIZZATI

### FOURNITURES ET OPTIONS

- PIEDS EN METAL STYLE CLASSIQUE
- COLONNE D'EVACUATION AVEC SIPHON VISIBLE
- ROBINETTERIE STYLE CLASSIQUE
- FINITION COLONNE ET PIEDS : CHROME, OR ET BRONZE
- DECORS PERSONNALISES

### FEATURES AND OPTIONALS

- METAL FEET IN CLASSIC STYLE
- DRAIN COLUMN WITH VISIBLE TRAP
- CLASSIC-STYLE FAUCETS
- COLUMN AND FEET FINISH: CHROME, GOLD AND BRONZE
- CUSTOM DECORATIONS

### CARACTERÍSTICAS Y COMPLEMENTOS

- PIES DE METAL ESTILO CLÁSICO
- COLUMNA DE DESAGÜE CON SIFÓN A LA VISTA
- GRIFERÍA DE ESTILO CLÁSICO
- ACABADOS COLUMNA Y PIES: CROMO, ORO Y BRONCE
- DECORACIÓN PERSONALIZADA



# Niña

designer Anika Elisabetta Luceri

170 X 80 X 75h.

Niña  
239





Niña  
170 X 80 X 75h.

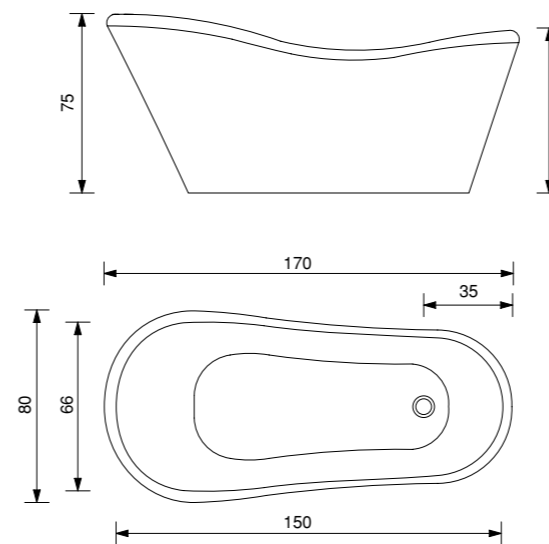

- DOTAZIONI E OPTIONAL
- PANNELLO ESTERNO UNICO PEZZO
  - DECORI PERSONALIZZATI

- FOURNITURES ET OPTIONS
- PANNEAU EXTERNE D'UNE SEULE PIECE
  - DECORS PERSONNALISES

- FEATURES AND OPTIONALS
- ONE PIECE OUTER PANEL
  - CUSTOM DECORATIONS

- CARACTERÍSTICAS Y COMPLEMENTOS
- PANEL EXTERIOR DE UNA PIEZA
  - DECORACIÓN PERSONALIZADA

*Dada*

80 X 80 X 222h.  
90 X 90 X 222h.  
80 X 100 X 222h.



Page

246

*Elle*

70 X 90 X 207h.  
80 X 125 X 207h.



252

*Flat*

90 X 90 X 215h.  
80 X 100 X 215h.  
80 X 160 X 215h.



266

*Idea*

82 X 90 X 216h.



282

*Pack*

90 X 90 X 217h.  
90 X 120 X 217h.



292

*Stone midi*

80 X 80 X 215h.  
90 X 90 X 215h.  
80 X 100 X 215h.



306

*Stone top*

80 X 80 X 221h.  
90 X 90 X 221h.  
80 X 100 X 221h.



310

*Stone tria*

90 X 90 X 225h.  
80 X 100 X 226h.



316



# Dada

designer Paolo Parea

80 X 80 X 222h. 90 X 90 X 222h. 80 X 100 X 222h.



tresse

HOME

Dada 90 X 90  
247

BOX DOCCIA  
SHOWER CUBICLES



*Dada 80 X 100*  
248



*Dada*  
249



# Dada

80 X 80 X 222h. 90 X 90 X 222h. 80 X 100 X 222h.

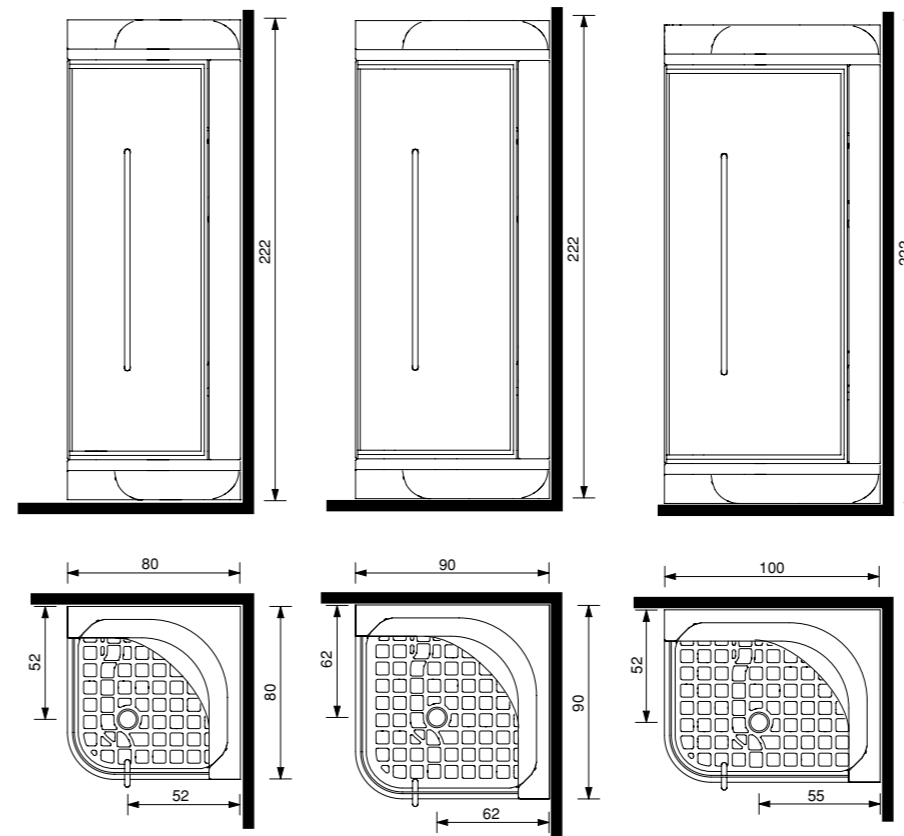

### DOTAZIONI E OPTIONAL

- CRISTALLO TEMPERATO DA 6 MM
- JET MASSAGGIO VERTICALE
- JET MASSAGGIO DORSALE
- BAGNO TURCO
- DOCCIONE
- DOCCIA SCOZZESE
- DOCCIA A CASCATA
- RUBINETTERIA
- DOCCETTA
- RIPIANO PORTA OGGETTI
- CROMOTERAPIA
- FARO
- RADIO
- INGRESSO AUDIO IPOD/CD

### FEATURES AND OPTIONALS

- TEMPERED GLASS, 6 MM
- VERTICAL MASSAGE JET
- BACK MASSAGE JET
- STEAM BATH
- SHOWER HEAD
- SCOTTISH SHOWER
- CASCADE SHOWER
- FAUCETS
- SHOWER HAND UNIT
- TOILETRY SHELF
- COLOR THERAPY
- SPOTLIGHT
- RADIO
- AUDIO INPUT FOR IPOD/CD

### FOURNITURES ET OPTIONS

- VERRE TREMPÉ DE 6 MM
- JET MASSAGE VERTICAL
- JET MASSAGE DORSAL
- BAIN TURC
- POMME DE DOUCHE GRAND FORMAT
- DOUCHE ECOSSAISE
- DOUCHE EN CASCADE
- ROBINETTERIE
- DOUCHETTE
- ETAGERE PORTE-OBJETS
- CHROMOTHERAPIE
- SPOT
- RADIO
- ENTREE AUDIO IPOD/CD

### CARACTERÍSTICAS Y COMPLEMENTOS

- CRISTAL TEMPLADO DE 6 MM
- CHORRO MASAJE VERTICAL
- CHORRO MASAJE DORSAL
- BAÑO TURCO
- ALCACHOFA CENTRAL
- DUCHA ESCOCESA
- DUCHA EN CASCADA
- GRIFERÍA
- TELÉFONO DUCHA
- ESTANTE PORTAOBJETOS
- CROMOTERAPIA
- LUZ
- RADIO
- ENTRADA DE AUDIO PARA IPOD/CD

Elle

designer Paolo Parea

70 X 90 X 207h. 80 X 125 X 207h.

Elle  
253

BOX DOCCIA  
SHOWER CUBICLES









Elle 80 X 125  
258



Elle 80 X 125  
259

tresse

HOME

BOX DOCCIA  
SHOWER CUBICLES





Elle 70 X 90  
262



tresse

HOME

Elle  
263

BOX DOCCIA  
SHOWER CUBICLES



# Elle

70 X 90 X 207h. 80 X 125 X 207h.

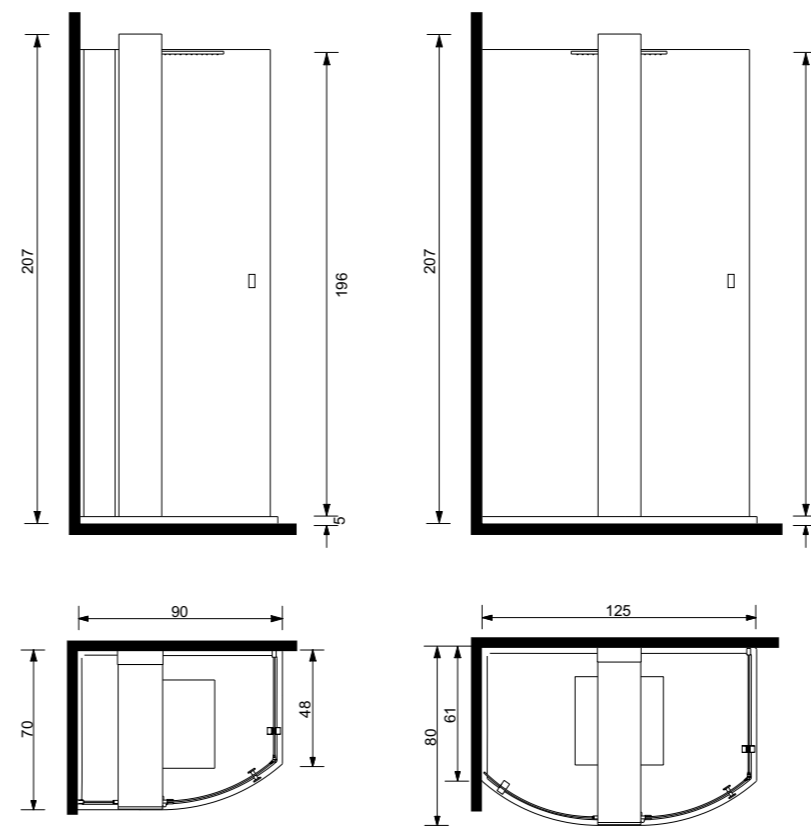

### DOTAZIONI E OPTIONAL

- CRISTALLO TEMPERATO DA 6 MM
- COLONNA MULTIFUNZIONE ISPEZIONABILE DALL'ESTERNO
- RUBINETTERIA
- SOFFIONE 30X30
- DOCCETTA
- MENSOLA PORTA OGGETTI
- FINITURE COLONNA: BIANCO, NERO E MARRONE TERRA BRUCIATA

### FOURNITURES ET OPTIONS

- VERRE TREMPÉ DE 6 MM
- COLONNE MULTIFONCTION INSPECTABLE DE L'EXTERIEUR
- ROBINETTERIE
- POMME DE DOUCHE 30X30
- DOUCHETTE
- ETAGERE PORTE-OBJETS
- FINITION COLONNE: BLANC, NOIR ET MARRON TERRE BRULEE

### FEATURES AND OPTIONALS

- TEMPERED GLASS, 6 MM
- MULTIPURPOSE COLUMN, CAN BE INSPECTED EXTERNALLY
- FAUCETS
- 30X30 SHOWER HEAD
- SHOWER HAND UNIT
- TOILETRY SHELF
- COLUMN FINISHES: WHITE, BLACK AND BROWN BURNISHED

### CARACTERÍSTICAS Y COMPLEMENTOS

- CRISTAL TEMPLADO DE 6 MM
- COLUMNA MULTIFUNCIÓN INSPECCIONABLE DESDE EL EXTERIOR
- GRIFERÍA
- ALCACHOFA 30X30
- TELÉFONO DUCHA
- ESTANTE PORTAOBJETOS
- ACABADOS COLUMNA: BLANCO, NEGRO Y MARRÓN TIERRA QUEMADA

### COLORI / COLOURS / COULEURS / COLORES



BIANCO  
WHITE  
BLANC  
BLANCO



NERO  
BLACK  
NOIR  
NEGRO



MARRONE TERRA BRUCIATA  
BROWN BURNISHED  
MARRON TERRE BRULEE  
MARRÓN TIERRA QUEMADA

# Flat

designer Fabrizio Batoni

90 X 90 X 215h. 80 X 100 X 215h. 80 X 160 X 215h.



tresse

HOME

Flat 80 X 160  
267

BOX DOCCIA  
SHOWER ENCLOSURES











Flat 90 X 90  
274

tresse

HOME



Flat  
275

BOX DOCCIA  
SHOWER CUBICLES







## Flat

90 X 90 X 215h. 80 X 100 X 215h. 80 X 160 X 215h.

tresse

HOME

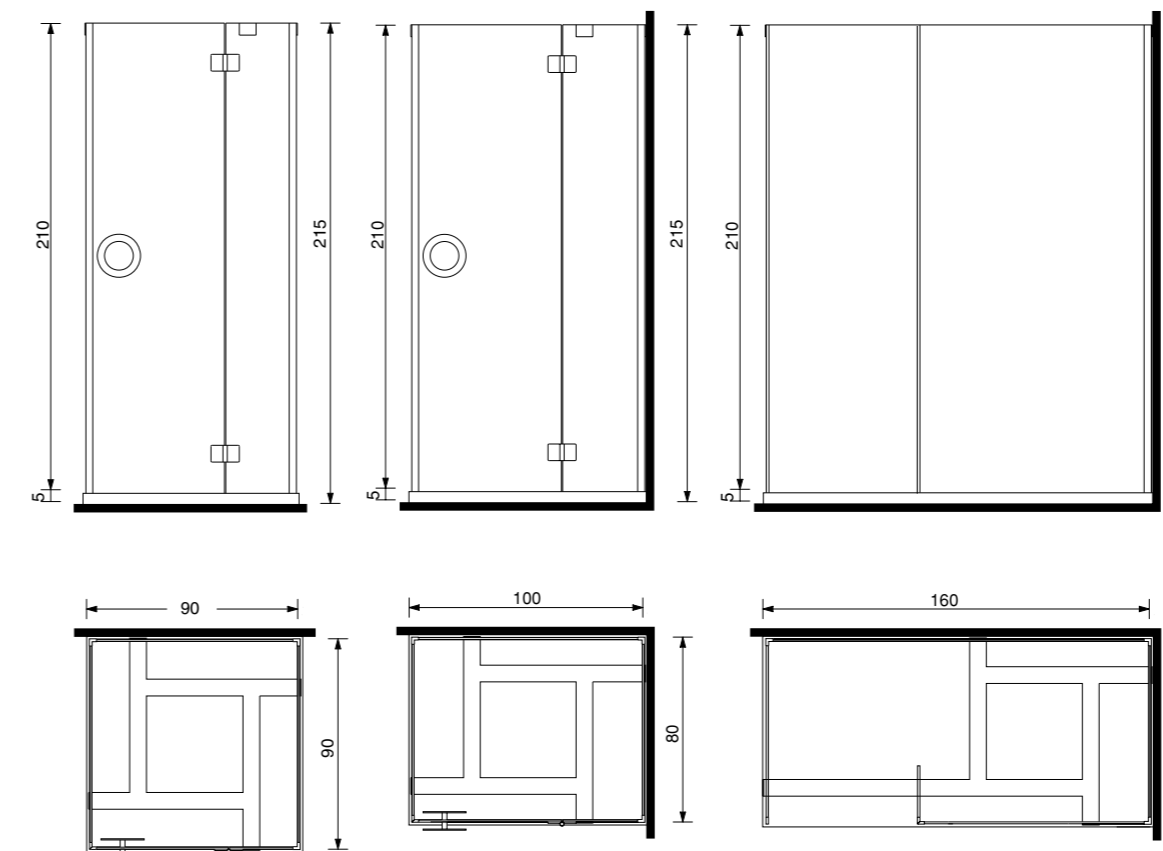

### DOTAZIONI E OPTIONAL

- CRISTALLO TEMPERATO DA 8 MM
- PIATTO DOCCIA A SKIMMER
- COLONNA ORIENTABILE CON JET MASSAGGIO VERTICALE
- STRUTTURA IN ACCIAIO BILUCIDO
- RUBINETTERIA
- SOFFIONE 40X40
- DOCCETTA
- MENSOLA PORTA OGGETTI
- FINITURE CRISTALLI: BIANCO, NERO E ROSSO

### FEATURES AND OPTIONALS

- TEMPERED GLASS, 8 MM
- SKIMMER TRAY
- ADJUSTABLE COLUMN WITH VERTICAL MASSAGE JETS
- DOUBLE-POLISHED STEEL STRUCTURE
- FAUCETS
- 40X40 SHOWER HEAD
- SHOWER HAND UNIT
- TOILETRY SHELF
- GLASS FINISHES: WHITE, BLACK AND RED

### FOURNITURES ET OPTIONS

- VERRE TREMPÉ DE 8 MM
- RECEVEUR A SKIMMER
- COLONNE ORIENTABLE AVEC JET DE MASSAGE VERTICAL
- STRUCTURE EN ACIER POLI DES DEUX COTES
- ROBINETTERIE
- POMME DE DOUCHE 40X40
- DOUCHETTE
- ETAGERE PORTE-OBJETS
- FINITIONS DES VITRES: BLANC, NOIR ET ROUGE

### CARACTERÍSTICAS Y COMPLEMENTOS

- CRISTAL TEMPLADO DE 8 MM
- PLATO DUCHA CON SKIMMER
- COLUMNA ORIENTABLE CON CHORRO MASAJE VERTICAL
- ESTRUCTURA DE ACERO BRILLANTE POR AMBAS CARAS
- GRIFERÍA
- ALCACHOFA 40X40
- TELÉFONO DUCHA
- ESTANTE PORTAOBJETOS
- ACABADO CRISTALES: BLANCO, NEGRO Y ROJO

### COLORI / COLOURS / COULEURS / COLORES

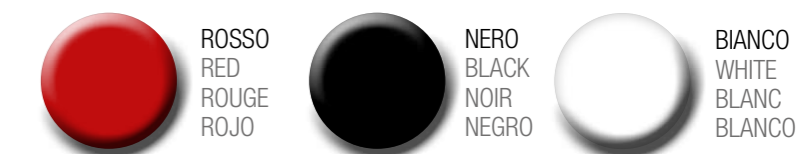



Idea

designer Marc Sadler

82 X 90 X 216h.

Idea walk through  
283



*Piatto e parete incassati*  
*Recessed tray and wall*  
*Receveur et parois encastrés*  
*Plato y pared encastrados*











# Idea

82 X 90 X 216h.

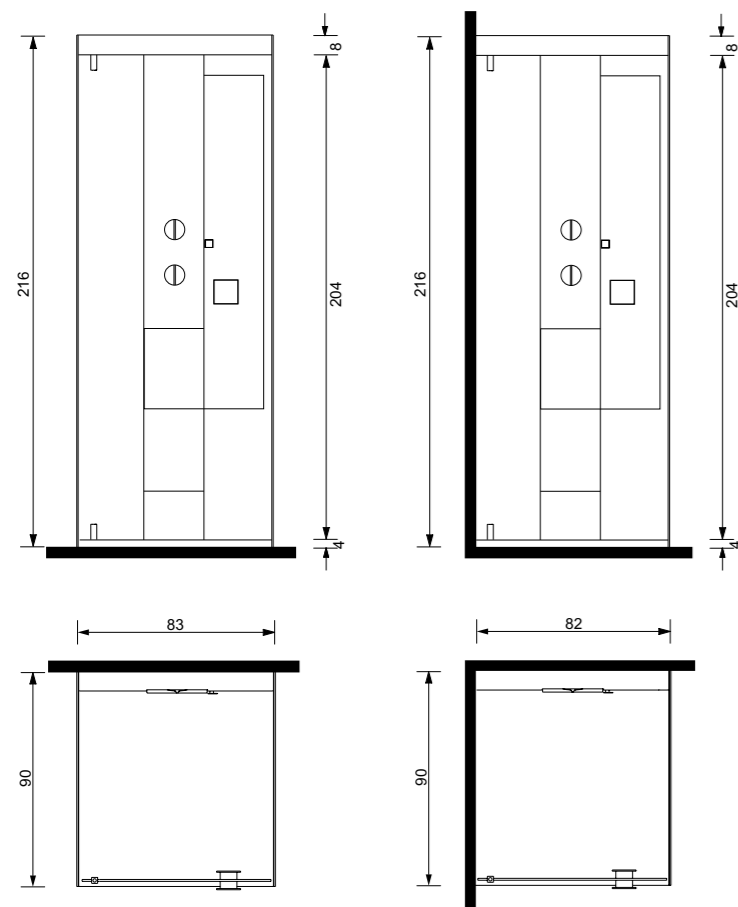

#### DOTAZIONI E OPTIONAL

- CRISTALLO TEMPERATO DA 8 MM
- PIATTO DOCCIA CON SCARICO A SCOMPARSA
- RUBINETTERIA CON COMANDI INTEGRATI
- SOFFIONE 40X40 INTEGRATO
- DOCCIA SUL TETTO A RISPARMIO IDRICO
- VANO PORTAOGGETTI CON DOCCETTA
- ILLUMINAZIONE A LED
- SEDILE RIBALTABILE A SCOMPARSA

#### FOURNITURES ET OPTIONS

- VERRE TREMPÉ DE 8 MM
- RECEVEUR DE DOUCHE AVEC EVACUATION INVISIBLE
- ROBINETTERIE AVEC COMMANDES INTEGRES
- POMME DE DOUCHE 40X40 INTEGREE
- POMME DE DOUCHE AU PLAFOND POUR ECONOMISER L'EAU
- COMPARTIMENT PORTE-OBJETS AVEC DOUCHETTE
- ECLAIRAGE A LEDS
- SIEGE RABATTABLE ESCAMOTABLE

#### FEATURES AND OPTIONALS

- TEMPERED GLASS, 8 MM
- TRAY WITH CONCEALED DRAIN
- FAUCETS WITH BUILT-IN CONTROLS
- BUILT-IN 40X40 SHOWER HEAD
- WATER-SAVING ROOF-MOUNTED SHOWER
- TOILETRY NICHE WITH HAND UNIT
- LED LIGHTING
- FOLD-AWAY SEAT

#### CARACTERÍSTICAS Y COMPLEMENTOS

- CRISTAL TEMPLADO DE 8 MM
- PLATO DUCHA CON DESAGÜE OCULTO
- GRIFERÍA CON MANDOS INTEGRADOS
- ALCACHOFA 40 X 40 INTEGRADA
- DUCHA SUPERIOR CON AHORRO HÍDRICO
- HUECO PORTAOBJETOS CON TELÉFONO DUCHA
- ILUMINACIÓN CON LED
- ASIENTO BASCULANTE RETRÁCTIL



APPOGGIO  
SURFACE MOUNTED  
APPUI  
APOYO



PIATTO E PARETE INCASSATI  
RECESSED TRAY AND WALL  
RECEVEUR ET PAROIS ENCASTRES  
PLATO Y PARED ENCASTRADOS

# Pack

designer Marc Sadler

90 X 90 X 217h. 90 X 120 X 217h.



tresse

HOME

Pack 120 walk through  
293

BOX DOCCIA  
SHOWER CUBICLES







*Piatto e parete incassati  
Recessed tray and wall  
Receveur et parois encastrés  
Plato y pared encastrados*





*Piatto e parete incassati*  
*Recessed tray and wall*  
*Receveur et parois encastrés*  
*Plato y pared encastrados*





# Pack

90 X 90 X 217h. 90 X 120 X 217h.

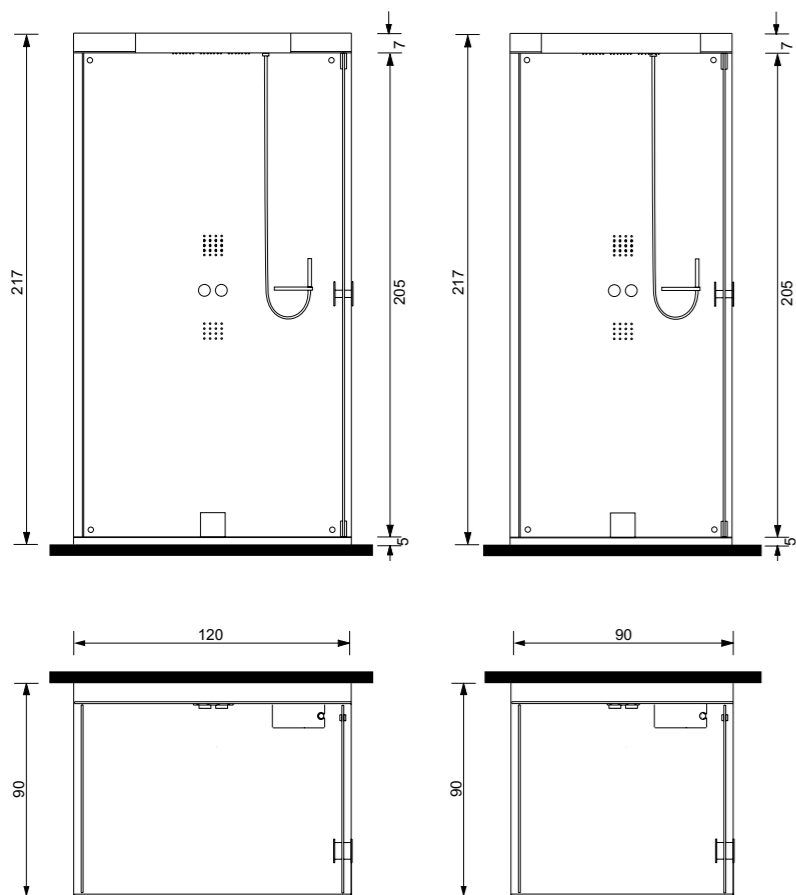

## DOTAZIONI E OPTIONAL

- CRISTALLO TEMPERATO DA 8 MM
- PIATTO DOCCIA CON SCARICO A SCOMPARSA
- RUBINETTERIA
- SOFFIONE 40X40 INTEGRATO
- DOCCETTA
- JET MASSAGGIO VERTICALE
- MENSOLA PORTA OGGETTI
- FINITURE CRISTALLI:  
BIANCO, NERO E ROSSO
- COMANDO FUNZIONI DIGITALE

## FOURNITURES ET OPTIONS

- VERRE TREMPÉ DE 8 MM
- RECEVEUR DE DOUCHE AVEC EVACUATION ESCAMOTABLE
- ROBINETTERIE
- POMME DE DOUCHE 40X40 INTEGEE
- DOUCHETTE
- JET MASSAGE VERTICAL
- ETAGERE PORTE-OBJETS
- FINITIONS DES VITRES:  
BLANC, NOIR ET ROUGE
- COMMANDE FONCTIONS NUMERIQUES

## COLORI / COLOURS / COULEURS / COLORES



**ROSSO**  
RED  
ROUGE  
ROJO

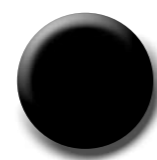

**NERO**  
BLACK  
NOIR  
NEGRO



**BIANCO**  
WHITE  
BLANC  
BLANCO

## FEATURES AND OPTIONALS

- TEMPERED GLASS, 8 MM
- TRAY WITH CONCEALED DRAIN
- FAUCETS
- BUILT-IN 40X40 SHOWER HEAD
- SHOWER HAND UNIT
- VERTICAL MASSAGE JET
- TOILETRY SHELF
- GLASS FINISHES:  
WHITE, BLACK AND RED
- DIGITAL FUNCTION CONTROL

## CARACTERÍSTICAS Y COMPLEMENTOS

- CRISTAL TEMPLADO DE 8 MM
- PLATO DUCHA CON DESAGÜE OCULTO
- GRIFERÍA
- ALCACHOFA 40 X 40 INTEGRADA
- TELÉFONO DUCHA
- CHORRO MASAJE VERTICAL
- ESTANTE PORTAOBJETOS
- ACABADO CRISTALES:  
BLANCO, NEGRO Y ROJO
- MANDO FUNCIONES DIGITAL



**APPOGGIO**  
SURFACE MOUNTED  
APPUI  
APOYO



**PIATTO E PARETE INCASSATI**  
RECESSED TRAY AND WALL  
RECEVEUR ET PAROIS ENCASTRES  
PLATO Y PARED ENCASTRADOS

**TASTO ON/OFF (temporizzato)**  
ON/OFF KEY (time control)  
TOUCHE ON/OFF (temporisée)  
TECLA ON/OFF (temporizado)



**SOFFIONE DOCCIA**  
SHOWER HEAD  
POMME DE DOUCHE  
ALCACHOFA DE DUCHA



**GETTI VERTICALI**  
VERTICAL JETS  
JETS VERTICAUX  
CHORROS VERTICALES



**DOCCETTA**  
SHOWER HAND UNIT  
DOUCHETTE  
TELÉFONO DUCHA



**TASTO ECO**  
ECO KEY  
TOUCHE ECO  
TECLA ECO



**MISCELAZIONE ACQUA**  
MIXER TAP  
MELANGE EAU  
MEZCLA AGUA



**PORTATA ACQUA**  
WATER FLOW  
DEBIT EAU  
CAUDAL AGUA



# Stone midi

designer Paolo Parea

80 X 80 X 215h. 90 X 90 X 215h. 80 X 100 X 215h.



Stone midi 80  
307



Stone midi 90  
308



Stone midi 100  
309

# Stone top

designer Paolo Parea

80 X 80 X 221h. 90 X 90 X 221h. 80 X 100 X 221h.



tresse

HOME

Stone top 90  
311

BOX DOCCIA  
SHOWER CUBICLES



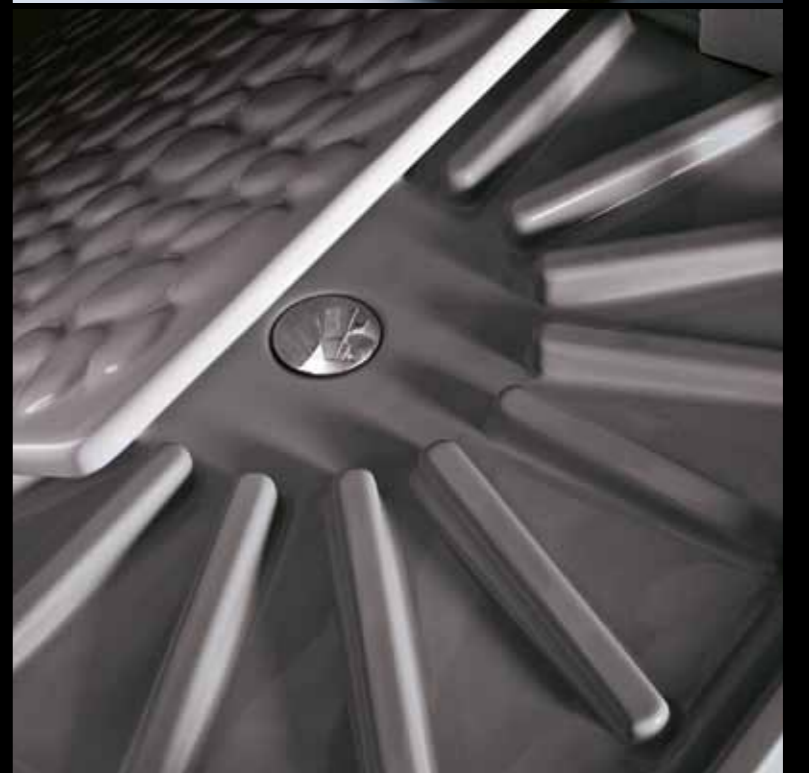



# Stone tria

designer Paolo Parea

90 X 90 X 225h. 80 X 100 X 226h.



tresse

HOME

Stone tria 90  
317

BOX DOCCIA  
SHOWER CUBICLES







## Stone midi

80 X 80 X 215h. 90 X 90 X 215h. 80 X 100 X 215h.

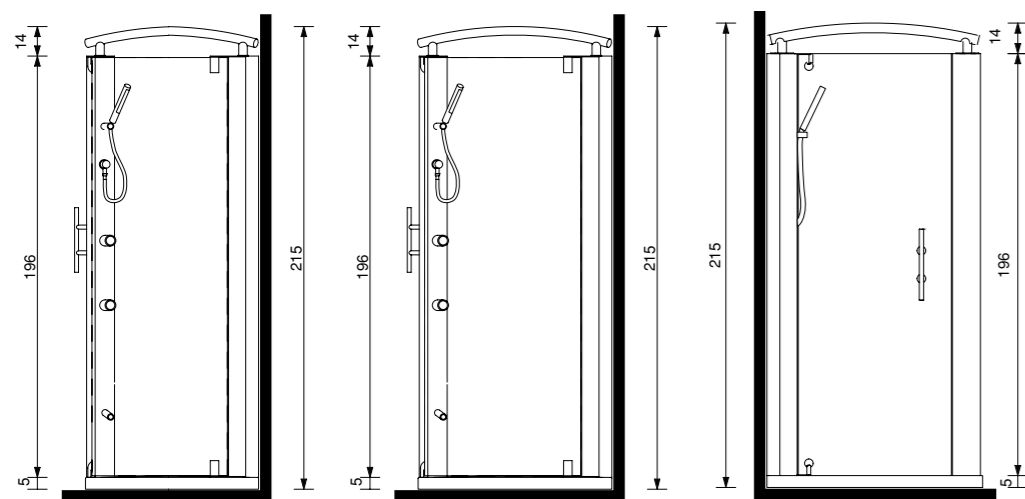

### DOTAZIONI E OPTIONAL

- CRISTALLO TEMPERATO DA 8 MM
- PIATTO DOCCIA CON SCARICO A SKIMMER
- COLONNE MULTIFUNZIONE:  
JET MASSAGGIO VERTICALE  
RUBINETTERIA  
DOCCETTA CON SUPPORTO SNODATO  
MENSOLA PORTA OGGETTI

### FOURNITURES ET OPTIONS

- VERRE TREMPÉ DE 8 MM
- RECEVEUR AVEC EVACUATION A SKIMMER
- COLONNES MULTIFONCTION:  
JET MASSAGE VERTICAL  
ROBINETTERIE  
DOUCHETTE AVEC SUPPORT ARTICULE  
ETAGERE PORTE-OBJETS

### FEATURES AND OPTIONALS

- TEMPERED GLASS, 8 MM
- SKIMMER TRAY
- MULTIPURPOSE COLUMNS:  
VERTICAL MASSAGE JET  
FAUCETS  
FLEX HAND UNIT  
TOILETRY SHELF

### CARACTERÍSTICAS Y COMPLEMENTOS

- CRISTAL TEMPLADO DE 8 MM
- PLATO DUCHA CON DESAGÜE EN SKIMMER
- COLUMNAS MULTIFUNCIÓN:  
CHORRO MASAJE VERTICAL  
GRIFERÍA  
TELÉFONO DUCHA CON SOPORTE ARTICULADO  
ESTANTE PORTAOBJETOS

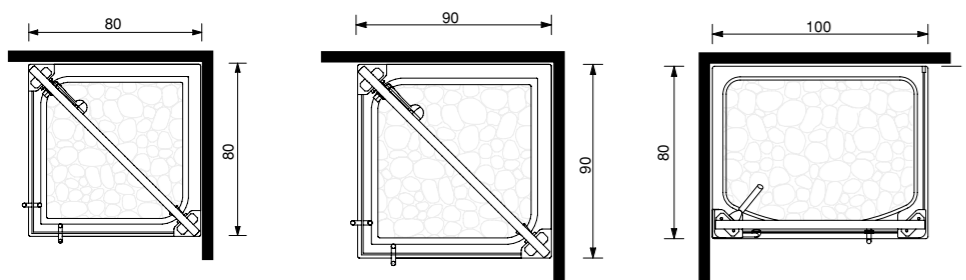

## Stone top

80 X 80 X 221h. 90 X 90 X 221h. 80 X 100 X 221h.

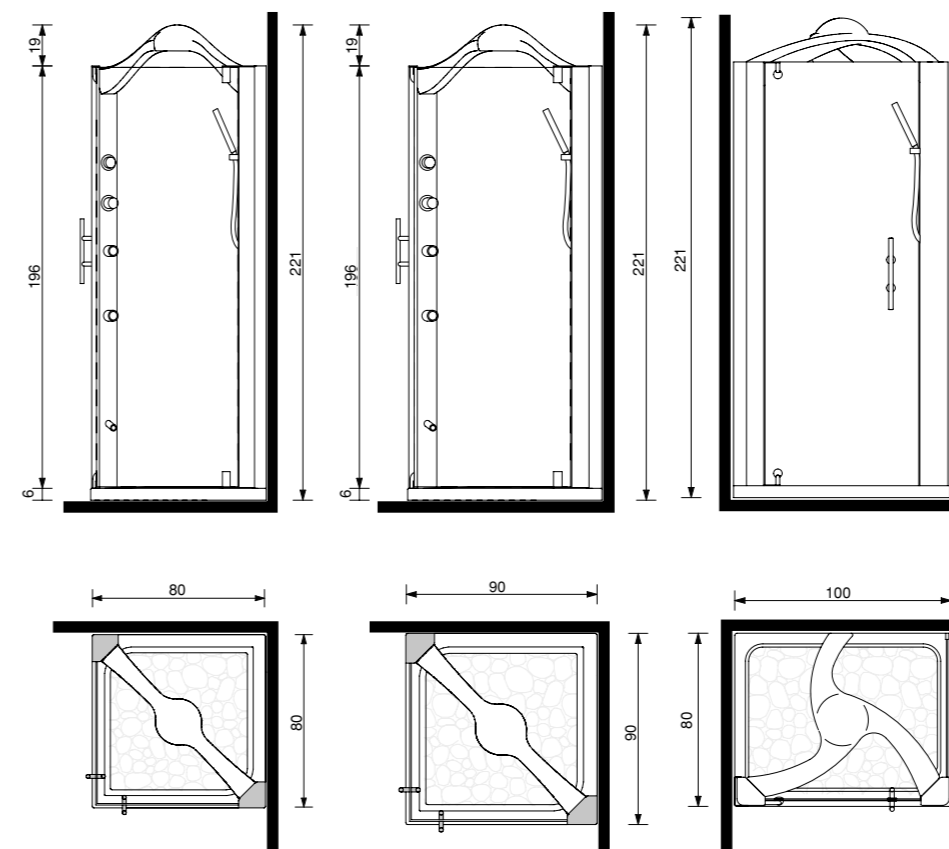

### DOTAZIONI E OPTIONAL

- CRISTALLO TEMPERATO DA 8 MM
- PIATTO DOCCIA CON SCARICO A SKIMMER
- COLONNE MULTIFUNZIONE:  
JET MASSAGGIO VERTICALE  
RUBINETTERIA  
DOCCETTA CON SUPPORTO SNODATO  
MENSOLA PORTA OGGETTI
- TETTO MULTIFUNZIONE:  
DOCCIONE  
NEBULIZZATORI INTEGRATI

### FOURNITURES ET OPTIONS

- VERRE TREMPÉ DE 8 MM
- RECEVEUR AVEC EVACUATION A SKIMMER
- COLONNES MULTIFONCTION:  
JET MASSAGE VERTICAL  
ROBINETTERIE  
DOUCHETTE AVEC SUPPORT ARTICULE  
ETAGERE PORTE-OBJETS
- PLAFOND MULTIFONCTION:  
POMME DE DOUCHE GRAND FORMAT  
NEBULISEURS INTEGRES

### FEATURES AND OPTIONALS

- TEMPERED GLASS, 8 MM
- SKIMMER TRAY
- MULTIPURPOSE COLUMNS:  
VERTICAL MASSAGE JET  
FAUCETS  
FLEX HAND UNIT  
TOILETRY SHELF
- MULTIPURPOSE ROOF:  
SHOWER HEAD  
BUILT-IN MISTERS

### CARACTERÍSTICAS Y COMPLEMENTOS

- CRISTAL TEMPLADO DE 8 MM
- PLATO DUCHA CON DESAGÜE EN SKIMMER
- COLUMNAS MULTIFUNCIÓN:  
CHORRO MASAJE VERTICAL  
GRIFERÍA  
TELÉFONO DUCHA CON SOPORTE ARTICULADO  
ESTANTE PORTAOBJETOS
- TECHO MULTIFUNCIÓN:  
ALCACHOFA CENTRAL  
NEBULIZADORES INTEGRADOS



# Stone tria

90 X 90 X 225h. 80 X 100 X 226h.

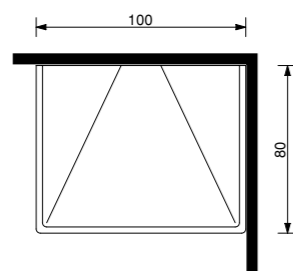
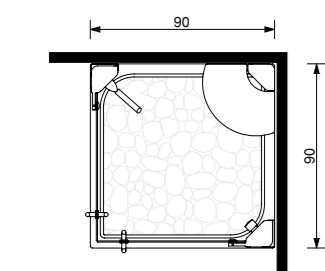
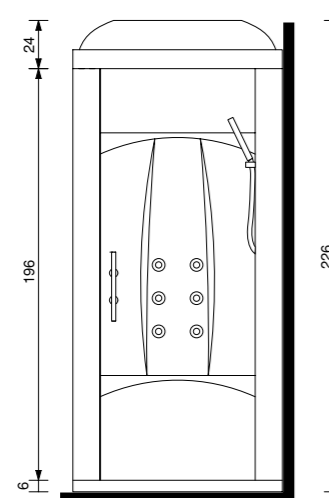
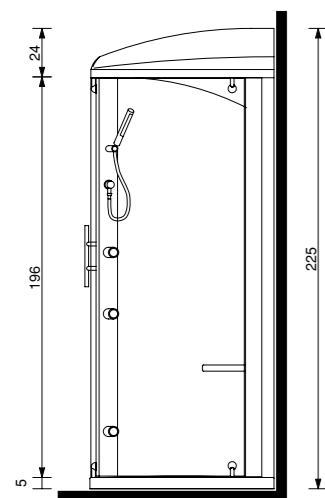

## DOTAZIONI E OPTIONAL

- CRISTALLO TEMPERATO DA 8 MM
- PIATTO DOCCIA CON SCARICO A SKIMMER
- BAGNO TURCO MONOCLIMA
- COLONNE MULTIFUNZIONE:  
JET MASSAGGIO VERTICALE  
RUBINETTERIA  
DOCCETTA CON SUPPORTO SNODATO  
MENSOLA PORTA OGGETTI
- TETTO MULTIFUNZIONE:  
DOCCIONE  
NEBULIZZATORI INTEGRATI
- SEDILE
- CROMOTERAPIA
- FARO
- RADIO
- INGRESSO AUDIO IPOD/CD
- CRISTALLI CON FINITURA A SPECCHIO

## FOURNITURES ET OPTIONS

- VERRE TREMPE DE 8 MM
- RECEVEUR AVEC EVACUATION A SKIMMER
- BAIN TURC MONO-CLIMAT
- COLONNES MULTIFONCTION:  
JET MASSAGE VERTICAL  
ROBINETTERIE  
DOUCHETTE AVEC SUPPORT ARTICULE  
ETAGERE PORTE-OBJETS
- PLAFOND MULTIFONCTION:  
POMME DE DOUCHE GRAND FORMAT  
NEBULISEURS INTEGRES
- SIEGE
- CHROMOTHERAPIE
- SPOT
- RADIO
- ENTREE AUDIO IPOD/CD
- VITRES FINITION BRILLANTE

## FEATURES AND OPTIONALS

- TEMPERED GLASS, 8 MM
- SKIMMER TRAY
- SINGLE-SETTING STEAM BAT
- MULTIPURPOSE COLUMNS:  
VERTICAL MASSAGE JET  
FAUCETS  
FLEX HAND UNIT  
TOILETRY SHELF
- MULTIPURPOSE ROOF:  
SHOWER HEAD  
BUILT-IN MISTERS
- SEAT
- COLOR THERAPY
- SPOTLIGHT
- RADIO
- AUDIO INPUT FOR IPOD/CD
- GLASS WITH MIRROR FINISH

## CARACTERÍSTICAS Y COMPLEMENTOS

- CRISTAL TEMPLADO DE 8 MM
- PLATO DUCHA CON DESAGÜE EN SKIMMER
- BAÑO TURCO MONOCLIMA
- COLUMNAS MULTIFUNCIÓN:  
CHORRO MASAJE VERTICAL  
GRIFERÍA  
TELÉFONO DUCHA CON SOPORTE ARTICULADO  
ESTANTE PORTAOBJETOS
- TECHO MULTIFUNCIÓN:  
ALCACHOFA CENTRAL  
NEBULIZADORES INTEGRADOS
- ASIENTO
- CROMOTERAPIA
- LUZ
- RADIO
- ENTRADA AUDIO PARA IPOD/CD
- CRISTALES CON ACABADO EN ESPEJO

concept e ideazione grafica  
GONNELLI & ASSOCIATI comunicazione

foto  
Lorenzo Borgianni  
Zerotremedia (pag.317)

stylist  
Paola Annunziata

stampa  
Tap Grafiche

© Gruppo Tre S s.p.a. marzo 2011

# treesse

GRUPPO TRE S s.p.a.  
01036 Nepi (Vt) Italia S.S. Cassia Km. 36,400 zona ind. Settevene  
Tel. (+39) 0761 527242 Fax (+39) 0761 527223  
info@gruppotres.it www.gruppotreesse.it

I dati e le caratteristiche indicate non impegnano il Gruppo Tre S spa, che si riserva il diritto di apportare delle modifiche ritenute opportune senza obbligo di preavviso o di sostituzione.  
The information and descriptions provided are not binding for Gruppo Tre S spa, which reserves the right to make any changes it considers necessary without any obligations of pre-notification or replacement.  
Les données et caractéristiques indiquées ne concernent pas le Gruppo Tre S spa, qui se réserve le droit d'apporter les modifications qu'il juge opportunes, sans obligation de préavis ou de remplacement.  
Los datos y las características indicadas no comprometen al Grupo Tre S spa, que se reserva el derecho de aportar las modificaciones que considere oportunas sin obligación de previo aviso o de sustitución.