

STYLED
MODERNE

SAMUEL HEATH
since 1820

FINE CRAFTSMANSHIP,
CLASSIC AND
CONTEMPORARY DESIGN

**WELCOME TO OUR NEW STYLE MODERNE COLLECTION,
A RANGE INSPIRED BY THE GRACE AND GLAMOUR OF
THE ART DECO AGE.**

MANUFACTURING IN THE HEART OF ENGLAND SINCE 1820,
WE HAVE BECOME RENOWNED FOR OUR BEAUTIFULLY
DESIGNED AND INTRICATELY CRAFTED BATHROOM FITTINGS.

BLENDING TRADITIONAL SKILLS WITH THE VERY
LATEST TECHNOLOGY, WE ARE CREATING DISTINCTIVE
DESIGNS FOR INTERIOR DESIGNERS, ARCHITECTS AND
HOMEOWNERS ALL AROUND THE WORLD.

WE HOPE YOU ENJOY OUR NEW COLLECTION AS MUCH AS
WE HAVE TAKEN PLEASURE IN ITS DESIGN AND CREATION.

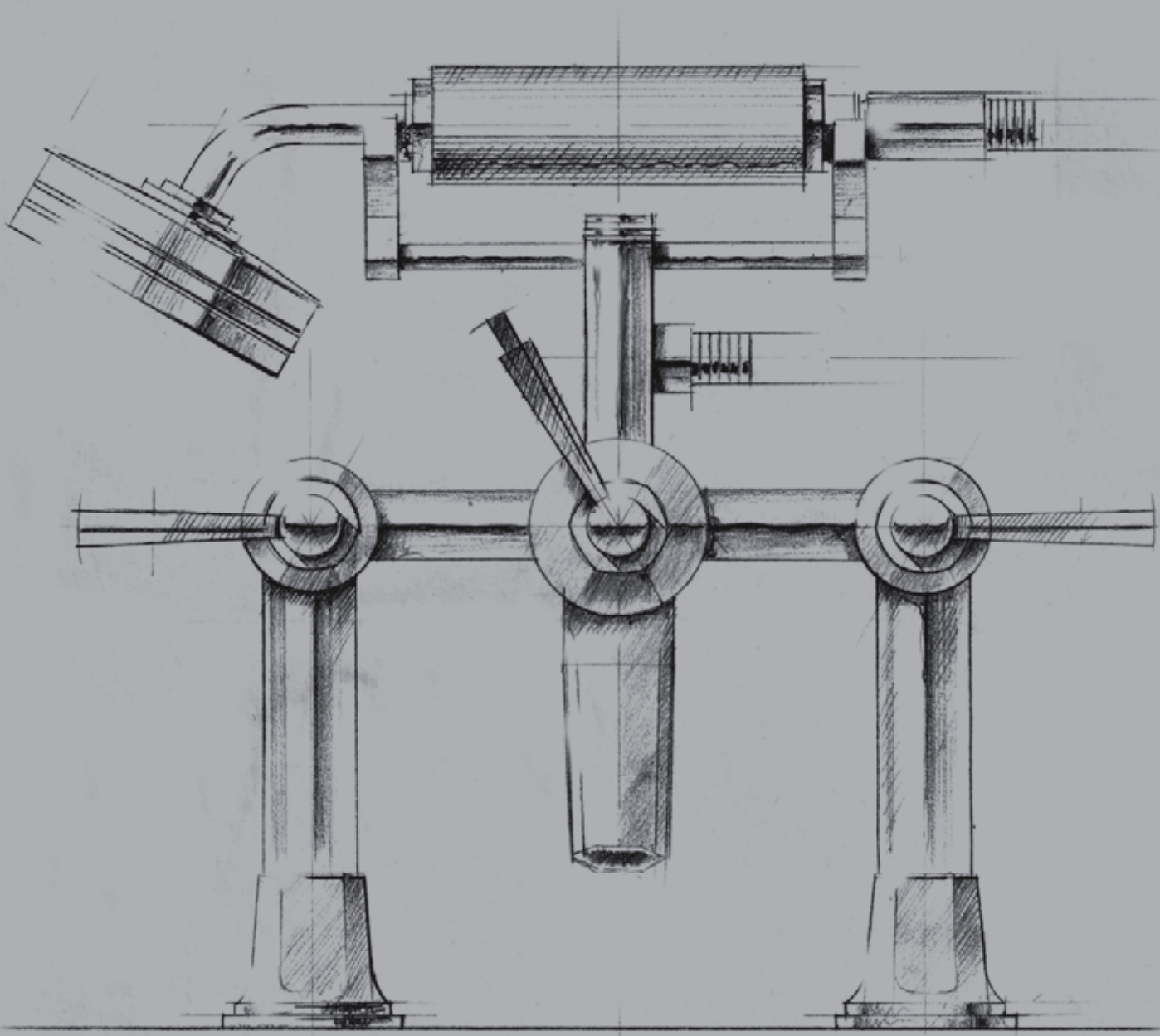

INTRODUCING
MODERNE

OUR NEW STYLE MODERNE COLLECTION HAS BEEN INSPIRED BY THE ICONIC ART DECO DESIGN PERIOD OF THE 1920'S AND 1930'S. THE MOVEMENT IS TYPIFIED BY ECLECTIC INFLUENCES WITH ITS ROOTS IN CUBISM AND FUTURISM, WELL KNOWN FOR ITS STRAIGHT LINES, RECTILINEAR FORMS AND GEOMETRIC SHAPES WITH STEPPED DETAIL. TAKING THESE ESSENTIAL TENETS AND THEMES, WE HAVE GIVEN THEM A UNIQUE AND CONTEMPORARY TWIST. ALL INFUSED WITH UNDILUTED PASSION AND THE MANUFACTURING EXCELLENCE OF BRITISH CRAFTSMANSHIP.

The glamour, elegance and fluidity of the new collection reflect the authenticity of the era, yet its own individual identity is secured with a dramatic and courageous reinterpretation. Clean, defined lines of linearity remain faithful to the period, black chrome lever and cross top elements demand to be noticed, faceted spouts enhance geometric shapes and stepped details all add a classic feel with contemporary overtones.

Samuel Heath has successfully reinterpreted one of the most dynamic and influential artistic periods in history. Style Moderne - the original name for Art Deco - is an authentic collection of exquisite bathroom fittings that reflect the elegance and grace of the period.

THE DOUGLAS DC-3 IS RECOGNISED AS ONE OF THE MOST AESTHETICALLY BEAUTIFUL AIRCRAFTS BUILT.



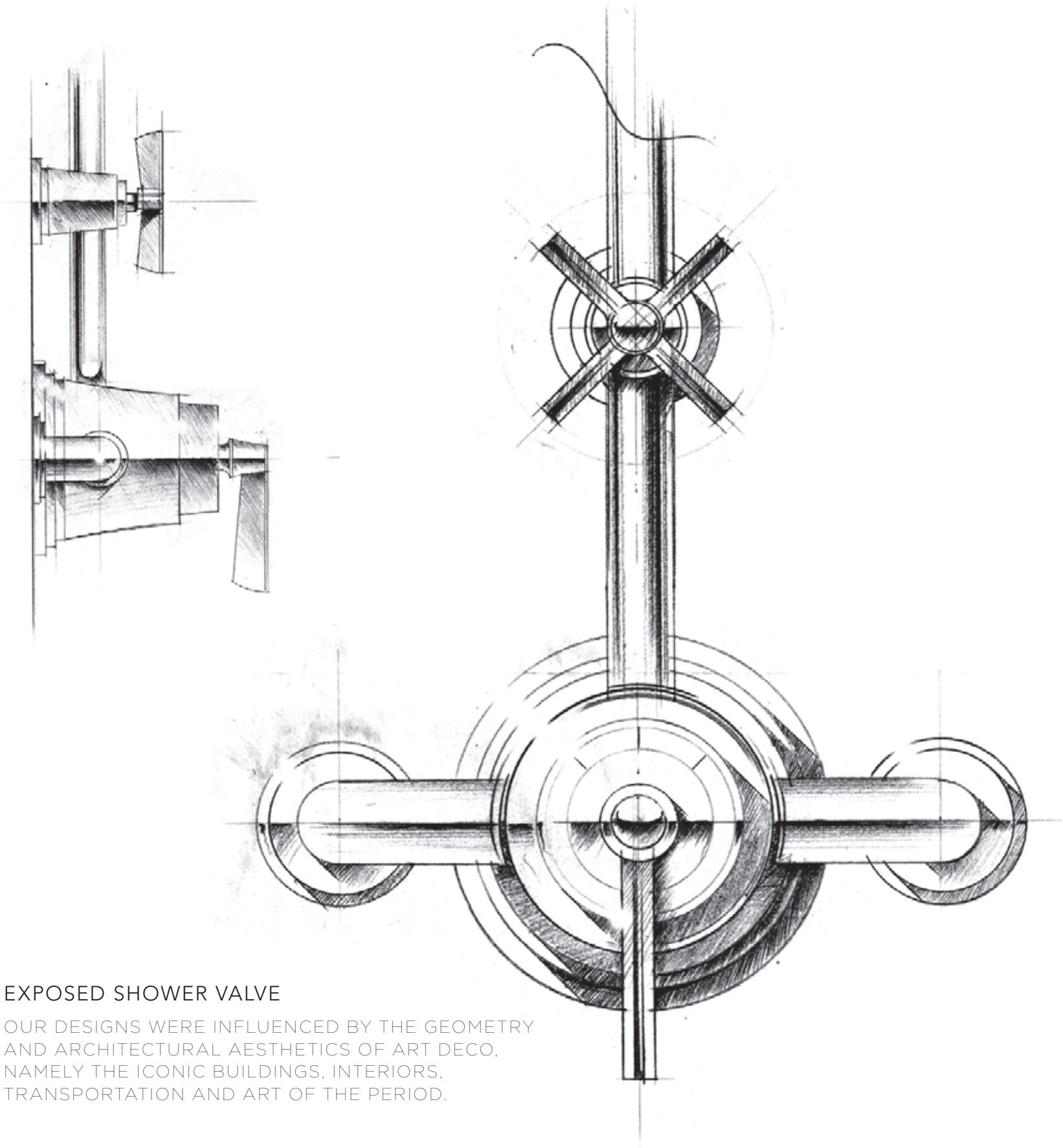

EXPOSED SHOWER VALVE

OUR DESIGNS WERE INFLUENCED BY THE GEOMETRY AND ARCHITECTURAL AESTHETICS OF ART DECO, NAMELY THE ICONIC BUILDINGS, INTERIORS, TRANSPORTATION AND ART OF THE PERIOD.

"WE STAND AT THE GATES OF ANOTHER WORLD, A WORLD WHERE

GATE AND DISCOVER THE NEW." PARIS MAGDALINOS, 1942-2008



WITH IT A NEW FORM OF ARCHITECTURE WILL RISE. LET'S OPEN THE

THE ACCOMPLISHED WILL BE OVERCOME BY THE DETERMINED AND

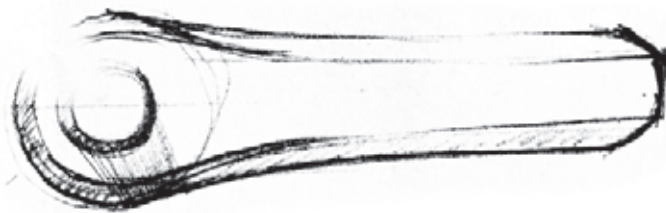
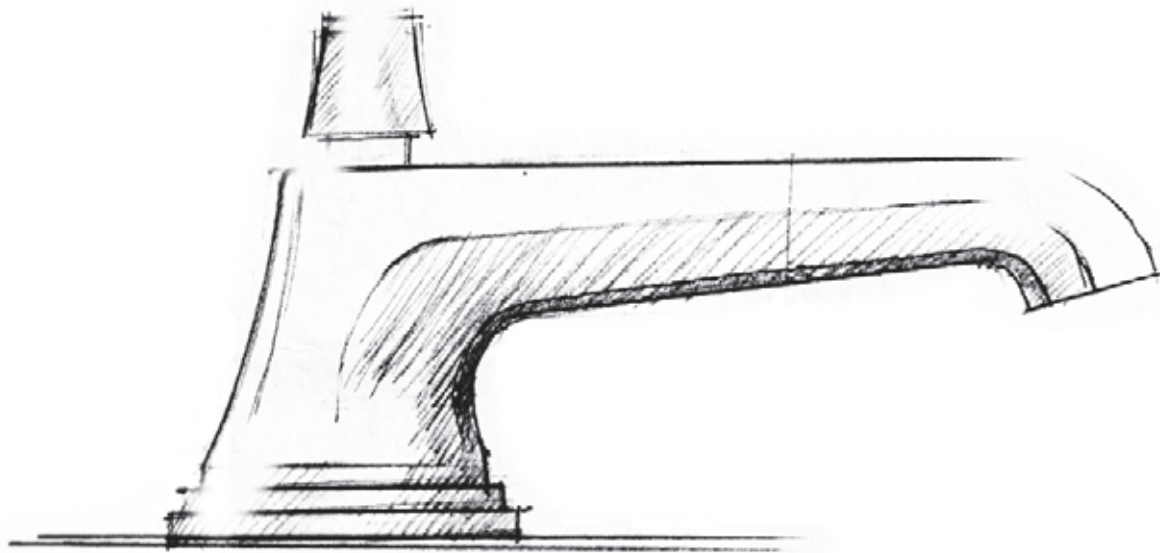

BASIN TAPS

SUBTLE BUT RECOGNISABLE
DETAILS FROM THE ERA ARE
STRONGLY REPRESENTED
THROUGHOUT THE DESIGNS.

THREE HOLE BASIN FILLER

A CONTEMPORARY INTERPRETATION
OF ART DECO DESIGN WITH STRONG,
CONFIDENT LINES ENHANCED BY
CONTRASTING GLOSS BLACK LEVERS.





THREE HOLE BASIN FILLER

THE ORIENTATION OF THIS DESIGN
REFLECTS THE VISUAL LANGUAGE OF
THE TIME, MOST NOTABLY DEPICTED BY
THE FACETTED SPOUT.

THREE HOLE BIDET

REFERENCING THE KEY
FEATURES OF ART DECO, THE
GEOMETRIC STEPPED DESIGN
IS STRONGLY REPRESENTED.



BATH SHOWER MIXER

LUXURIANT IN DESIGN WITH
DEFINED LINES, THE BATH
SHOWER MIXER DRAWS ON
THE GLAMOUR AND GRACE
OF THE PERIOD.





BATH SHOWER MIXER

ENCOMPASSING THE SOPHISTICATION
OF THE PERIOD, CONFIDENT LINES ARE
SET AGAINST A FLUID CURVED SPOUT.



MARLIN

1700

“RHYTHMIC PLAY
OF PARTS, THE
POISE AND BALANCE,
THE RESPECT THE
FORMS PAY TO
THE MATERIALS,
AND THE REPOSE
THESE QUALITIES
ATTAIN TO”

FRANK LLOYD WRIGHT, 1867-1959



THREE HOLE BATH FILLER

CROSS TOP CONTROLS, GRAPHIC DETAIL AND THE
LINEATION OF THE SPOUT CONVEY A STRONG AESTHETIC.





FOUR HOLE BATH FILLER

RETAINING A FAITHFUL
APPROACH TO ART DECO,
STRONG LINES ARE COMBINED
WITH PRACTICALITY
REMINISCENT OF THE ERA.

EXPOSED THERMOSTATIC SHOWER

ONE CONTROL

CONVEYING A NAUTICAL FEEL
WITH CROSS TOP CONTROL AND
EXPOSED PIPEWORK, THE DESIGN
CARRIES A CLEAR REFERENCE TO
A LUXURY OCEAN LINER.





EXPOSED THERMOSTATIC SHOWER

TWO CONTROLS

REINTERPRETATION OF KEY
THEMES WITH CIRCULAR FORMS
AND CROSS TOPS - EVOCATIVE OF
THE ARCHITECTURAL MOTIF OF
THE OXO TOWER, LONDON.

CONCEALED THERMOSTATIC SHOWER

THERMOSTATIC & FLOW CONTROLS

STRONG AESTHETICS WITH COMBINATIONS
OF CONTROLS AND FINISHES, INSPIRED BY
THE CREATIVITY AND ARTISTIC EXPRESSION
OF THE ERA.





CONCEALED THERMOSTATIC SHOWER

ONE CONTROL

THE STYLISED ARCHITECTURAL SHAPES REDOLENT
OF THE TIME ARE ENHANCED THROUGH THE DEEP,
LUSTROUS CHROME FINISH.



CONCEALED THERMOSTATIC SHOWER

TWO CONTROLS

THE ORIENTATION OF THE CROSS TOP
AND LEVERS EPITOMIZES THE DISTINCTIVE
SYMMETRY OF STYLE MODERNE.

CONCEALED THERMOSTATIC SHOWER

DUAL CONTROL

THIS SHOWER VALVE ABOVE ALL
ENCAPSULATES THE CLEARLY DEFINED
FEATURES OF ART DECO DESIGN.





I DON'T THINK OF FORM AS
A KIND OF ARCHITECTURE.
THE ARCHITECTURE IS THE
RESULT OF THE FORMING.
IT IS THE KINESTHETIC
AND VISUAL SENSE OF
POSITION AND WHOLENESS
THAT PUTS THE THING INTO
THE REALM OF ART.

ROY LICHTENSTEIN, 1923-1997

FINISHES

POLISHED NICKEL
CHROME PLATE
ANTIQUUE GOLD
STAINLESS STEEL

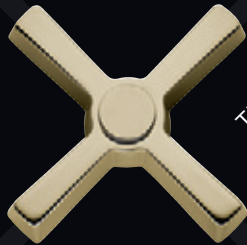

THE FINAL FINISHING TOUCH IN THE ART DECO PERIOD WAS AFFORDED THE
UTMOST IMPORTANCE, AND MUCH EXPERIMENTATION WAS UNDERTAKEN TO
CREATE THE MOST LUSTROUS, DECORATIVE AND PERFECT FINISH.

OUR STYLE MODERNE COLLECTION DISPLAYS THE SAME FLAWLESS, HIGH GLOSS
ATTENTION TO DETAIL WITH IMMENSURABLE DEPTH OF FINISH. MADE TO STAND
THE TEST OF TIME, EACH PRODUCT IS HAND POLISHED BY EXPERT CRAFTSMEN
BEFORE APPLYING A SUPERIOR, LONG LASTING ELECTROPLATED COATING.

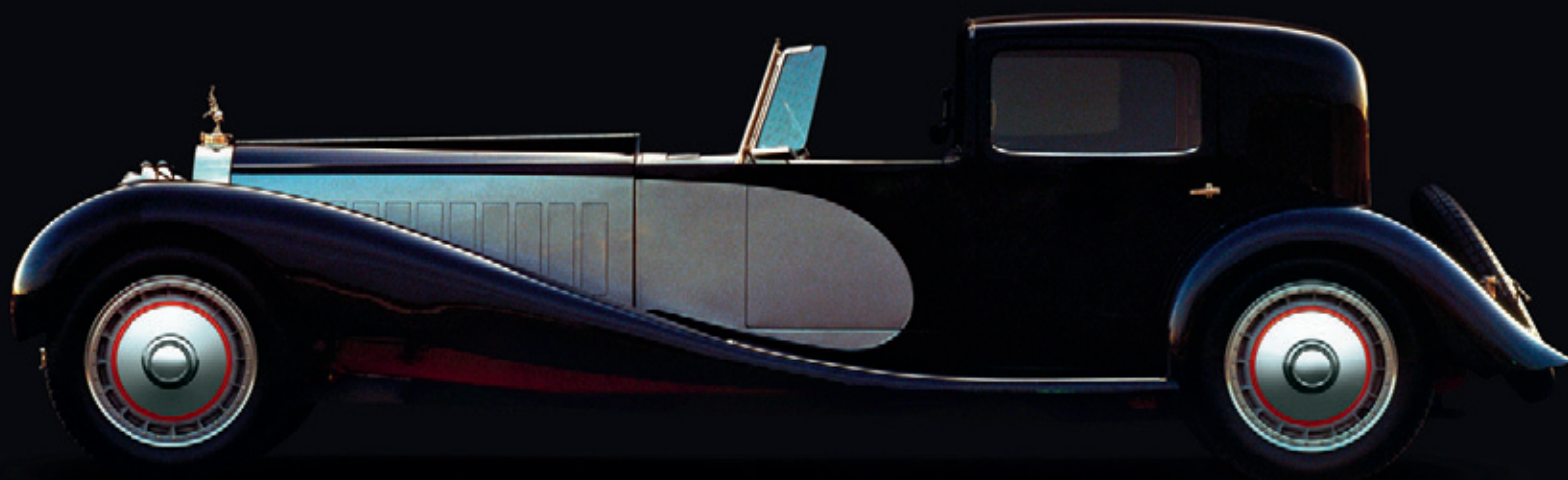

THE EXTRAVAGANT TYPE 41 BUGATTI WAS CONCEIVED BY ETTORE BUGATTI AS THE ULTIMATE CONVEYANCE OF ROYALTY. IRONICALLY, OF THE SEVEN CARS BUILT, NONE WERE ORIGINALLY SOLD TO ROYALTY. MANUFACTURED 1926 - 1933.

MSDN

THE STYLE MODERNE

THE BEAUTY OF THE STYLE MODERNE COLLECTION IS NOT JUST IN THE DESIGN AESTHETICS BUT THE FLEXIBILITY OF THE RANGE, ENABLING YOU TO CREATE YOUR OWN, BESPOKE BATHROOM IN PERIOD OR CONTEMPORARY SETTINGS, YOU CAN COMBINE OUR MANY FEATURES TO PORTRAY YOUR PERSONALITY AND ASPIRATIONS THROUGH THIS MOST FASHIONABLE OF DESIGN PERIODS.

SHOWROOM:

FIRST FLOOR NORTH DOME,
DESIGN CENTRE CHELSEA HARBOUR,
LOTS ROAD, LONDON SW10 0XE

T. +44 (0)20 7352 0249

E. SHOWROOM@SAMUEL-HEATH.COM

W. SAMUEL-HEATH.CO.UK

HEAD OFFICE & FACTORY:

LEOPOLD STREET,
BIRMINGHAM B12 0UJ, ENGLAND

T. +44 (0)121 766 4200

E. INFO@SAMUEL-HEATH.COM

USA OFFICE:

111 EAST 39TH STREET, SUITE 2R
NEW YORK, NY 10016 USA

T. 212 599 8177

E. USA@SAMUEL-HEATH.COM

