

THG<sup>®</sup>  
P A R I S

*French luxurious bathroom fittings*





# Sommaire

## Table of contents

## Übersicht

### INTRODUCTION

**Index alphabétique** ..... 11

*Alphabetical index*

Alphabetische Übersicht

**Index alphanumérique** ..... 12

*Alphanumeric index*

Alphanumerischen Übersicht

**Label EPV** ..... 13

*EPV label*

EPV Gütesiegel

**Références** ..... 14 - 17

*Project references*

Unsere Referenzen

**Partenaires & Designers** ..... 18 - 21

*Partners & Designers*

Partner & Designer

### COLLECTIONS

**Baccarat** ..... 22

**Lalique** ..... 34

**Daum** ..... 74

**Bernardaud** ..... 92

**Prestige** ..... 118

**Contemporaine** ..... 154

**Classique** ..... 194

**Traditionnelle** ..... 234

**Baroque** ..... 266

**Cascade** ..... 282

**Sky Showers & Hydromassage** ..... 296

**Vasques / Metal basins / Waschbecken** ..... 302

**Accessoires / Accessories / Accessoires** ..... 306

### L'ENTREPRISE

**THG** ..... 312

**Finitions / Finishes / Oberflächen** ..... 320

# Sommaire

## Table of contents

## Übersicht



Pétale de cristal clair  
U6A - Page 24



Pétale de cristal liseré  
doré U6E - Page 26



Pétale de cristal rouge  
U6C - Page 28



Pétale de cristal bleu  
U6B - Page 30



Pétale de cristal noir  
U6D - Page 32



Panthère cristal clair  
A2H - Page 36

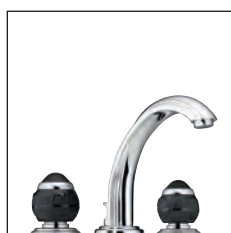

Panthère cristal noir  
A2K - Page 37



Métropolis cristal clair  
A2A - Page 40



Métropolis cristal noir  
A2L - Page 41



Métropolis  
à manettes cristal noir  
A2M - Page 42



Métropolis  
à manettes  
A2B - Page 43



Bambou cristal clair  
A35 - Page 44

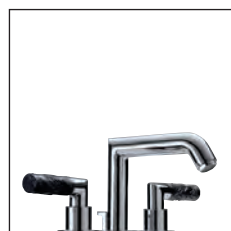

Bambou cristal noir  
A33 - Page 46

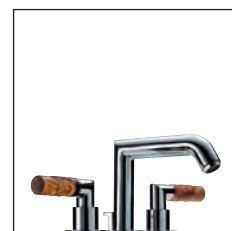

Bambou cristal ambre  
A34 - Page 47

# Sommaire

## Table of contents

## Übersicht



Masque de Femme  
métal lisse  
A2U - Page 48



Masque de Femme  
métal gravé  
A2T - Page 50



Masque de Femme  
lunaire  
A2R - Page 52



Masque de Femme  
solaire  
A2S - Page 54



Profil cristal clair  
A6G - Page 56



Profil cristal clair  
à manettes  
A6H - Page 58



Papillon  
A2J - Page 60



Ange  
A2G - Page 62



Venice  
A2E - Page 64



Oceania  
A2C - Page 66



Mossi cristal clair  
A2N - Page 68



Naïade  
A2F - Page 70



Perle\*  
A2i - Page 72

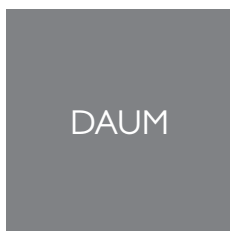

Sun Dragon  
U5D - Page 76



Moon Dragon  
U5G - Page 78



Jade Dragon  
U5H - Page 80



Island  
U5B - Page 82

# Sommaire

Table of contents

Übersicht



Paradise  
U5C - Page 84



Flore  
U5A - Page 86



Vegetal  
U5F - Page 88



Ginkgo  
U5E - Page 90



Marquise platine  
A7G - Page 94



Marquise doré  
A7F - Page 98



Ithaque platine  
A7B - Page 102



Ithaque doré  
A7A - Page 106



Capucine vert  
A7E - Page 110



Capucine mauve  
A7D - Page 114



Poèmes  
A7L - Page 120



Bagatelle  
U3A - Page 126



Bagatelle à manettes  
U3B - Page 126



Bagatelle pierre noire  
U3E - Page 128

# Sommaire

## Table of contents

## Übersicht

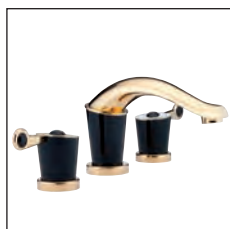

Bagatelle pierre noire  
à manettes  
U3F - Page 128



Bagatelle cristal  
U3C - Page 129



Vogue améthyste  
A8B - Page 130



Vogue jasper rouge  
A8N - Page 132



Vogue lapis lazuli  
A8S - Page 132



Vogue malachite  
A8M - Page 132



Vogue onyx noir  
A8P - Page 132



Vogue œil de tigre  
A8R - Page 132



Jaipur métal  
A9F - Page 134



Jaipur onyx noir  
A9C - Page 136



Jaipur cristal satiné  
A9B - Page 137



Trocadéro jasper rouge  
U7C - Page 140



Trocadéro lapis lazuli  
U7B - Page 140



Trocadéro malachite  
U7A - Page 140



Trocadéro onyx noir  
U7D - Page 140



Trocadéro œil de tigre  
U7E - Page 138



Amboise jasper rouge  
AIL - Page 142

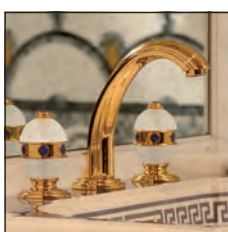

Amboise lapis lazuli  
AIK - Page 143



Amboise malachite  
AIJ - Page 143



Amboise onyx noir  
AIM - Page 143



# Sommaire

## Table of contents

## Übersicht



Chevry lapis lazuli  
AIT - Page 144



Chevry onyx noir  
UIV - Page 145



Chevry jaspé rouge  
AIU - Page 146



Chevry malachite  
AIS - Page 147



Sully onyx blanc  
UIS - Page 148



Sully jaspé rouge  
AIX - Page 149



Sully lapis lazuli  
AIW - Page 149



Sully malachite  
AIV - Page 149

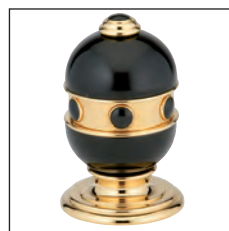

Sully onyx noir  
UIT - Page 149



Duomo  
U4E - Page 150



Duomo cristal  
U4F - Page 152



CONTEM-  
PORAINE



Collection O\*  
G4P - Page 156



Nano\*  
G5A - Page 160



Nano à manettes\*  
G5B - Page 162



Anoa corne claire\*  
G5C - Page 164



Anoa corne noire\*  
G5D - Page 168



Le II by Alberto Pinto  
U2A - Page 170



Le II by Alberto Pinto  
à manettes  
U2B - Page 172

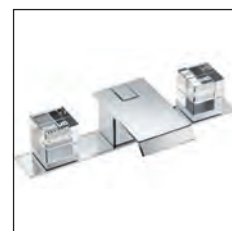

So  
U2K - Page 174

# Sommaire

## Table of contents

## Übersicht



Profil métal à manettes  
A6B - Page 178



Profil métal  
A6A - Page 181



Profil onyx noir  
A6N - Page 182



Profil onyx noir à manettes  
A6P - Page 183



Marina métal  
A6I - Page 184

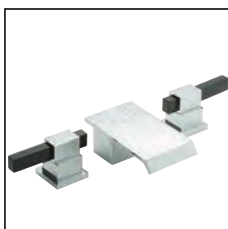

Marina onyx noir  
A6O - Page 186



Beluga  
GIT - Page 188



Beluga à manettes  
GIU - Page 190



Pure  
G04 - Page 192



Frivole  
G2R - Page 196

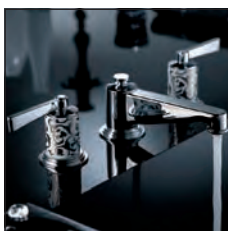

Frivole à manettes  
G2S - Page 196

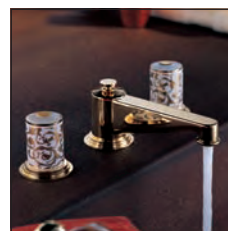

Froufrou  
G2N - Page 198

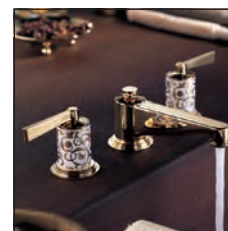

Froufrou à manettes  
G2P - Page 199



Faubourg porcelaine  
blanche  
G2K - Page 200



Faubourg porcelaine  
blanche à manettes  
G2J - Page 200

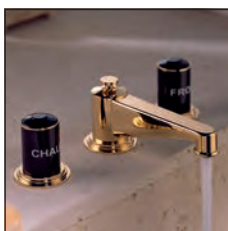

Faubourg porcelaine  
noire  
G2L - Page 202

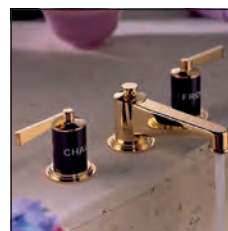

Faubourg porcelaine  
noire à manettes  
G2M - Page 203

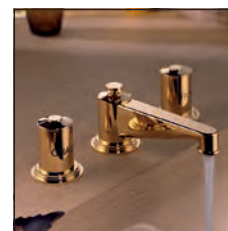

Faubourg métal  
G2T - Page 204

# Sommaire

## Table of contents

## Übersicht

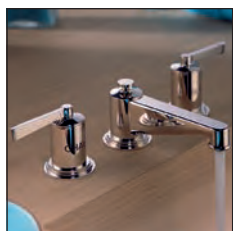

Faubourg métal à manettes  
G2U - Page 204



Mandarine métal  
U1A - Page 206

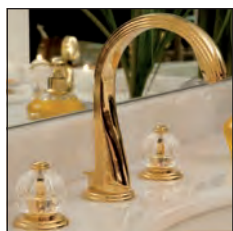

Mandarine cristal  
UID - Page 208



Mandarine cristal satiné  
UIE - Page 209



Mandarine Cristallia Diamant  
UIK - Page 212



Najem  
E53 - Page 214



Diplomate bagues lisses  
U4A - Page 216



Diplomate bagues annelées  
U4B - Page 218



Diplomate bagues torsadées  
U4C - Page 220



Diplomate Royale  
U4D - Page 222



Beverley  
J17 - Page 224



Cubica  
G79 - Page 226



Vendôme  
G47 - Page 228



Spirit  
G69 - Page 230



Spirit à manettes  
G58 - Page 232

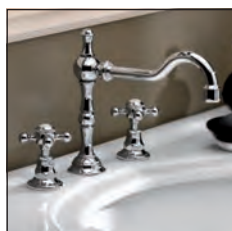

1900  
G25 - Page 236

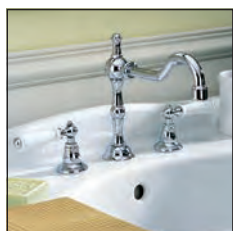

1900 à manettes  
G28 - Page 240

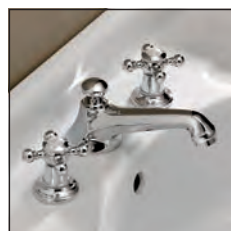

Charleston  
G29 - Page 242

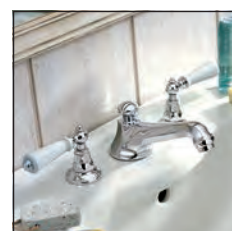

Charleston à manettes  
G75 - Page 246

# Sommaire

## Table of contents

## Übersicht



Art Déco  
A54 - Page 248



Art Déco à manettes  
A55 - Page 250

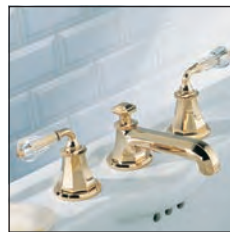

Art Déco cristal  
A56 - Page 252



Tradition  
A57 - Page 254



Tradition à manettes  
A58 - Page 256



Tradition cristal  
A59 - Page 258

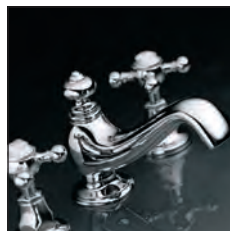

Broadway  
A52 - Page 260

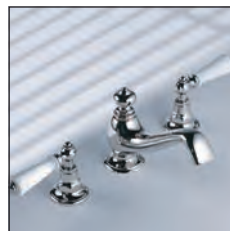

Broadway à manettes  
A04 - Page 262

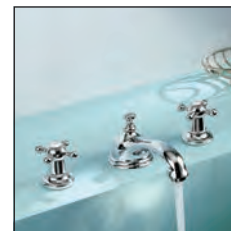

Pompadour  
G08 - Page 264



Malmaison métal\*  
U93 - Page 268



Malmaison cristal\*  
U94 - Page 270



Malmaison Bianca  
Carrara\*  
U96 - Page 272



Malmaison Portoro\*  
U95 - Page 273



Amour de Trianon  
G24 - Page 274



Cygne  
G31 - Page 276



Versailles  
G14 - Page 278



Tête de Lion  
G99 - Page 280

# Sommaire

Table of contents

Übersicht

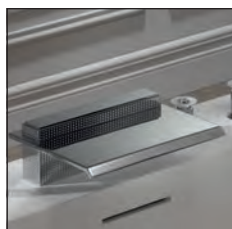

Perle\*  
A2i - Page 284



Le II by Alberto  
Pinto\*  
U2A - Page 288



Niagara  
A38 - Page 290



Urban  
A39 - Page 292

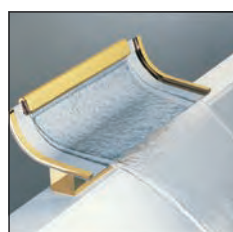

Ellipse  
A44 - Page 294

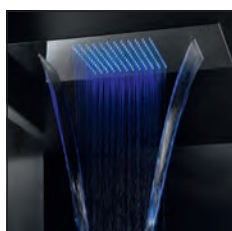

Sky showers  
Page 298



Hydromassage  
Page 300



Vasques métal  
GB2 - Page 304



Accessoires  
G00 - Page 308

# Index alphabétique

## Alphabetical index

## Alphabetische Übersicht

Series	Code	Page	Series	Code	Page	Series	Code	Page
1900.....	G25	236	Faubourg porcelaine noire.....	G2L	202	Paradise.....	U5C	84
1900 à manettes.....	G28	240	Faubourg porcelaine noire à man. ....	G2M	202	Perle bec cascade*.....	A2i	284
Accessoires Tous Styles.....	G00	306	Flore.....	U5A	86	Perle*.....	A2i	72
Amboise jaspé rouge.....	A1L	142	Frivole.....	G2R	196	Pétale de cristal bleu*.....	U6B	30
Amboise lapis lazuli.....	A1K	143	Frivole à manettes.....	G2S	196	Pétale de cristal clair*.....	U6A	24
Amboise malachite.....	A1J	143	Froufrou.....	G2N	198	Pétale de cristal liseré doré*.....	U6E	26
Amboise onyx noir.....	A1M	143	Froufrou à manettes.....	G2P	199	Pétale de cristal noir*.....	U6D	32
Amour de Trianon.....	G24	274	Ginkgo.....	U5E	90	Pétale de cristal rouge*.....	U6C	28
Ange.....	A2G	62	Island.....	U5B	82	Poèmes.....	A7L	120
Anoa corne claire*.....	G5C	164	Ithaque doré.....	A7A	106	Pompadour.....	G08	264
Anoa corne noire*.....	G5D	168	Ithaque platine.....	A7B	102	Profil cristal clair.....	A6G	56
Art Déco.....	A54	248	Jade Dragon.....	U5H	80	Profil cristal clair à manettes.....	A6H	58
Art Déco à manettes.....	A55	250	Jaipur cristal satiné.....	A9B	137	Profil métal.....	A6A	181
Art Déco cristal.....	A56	252	Jaipur métal.....	A9F	134	Profil métal à manettes.....	A6B	178
Bagatelle.....	U3A	126	Jaipur onyx noir.....	A9C	136	Profil onyx noir.....	A6N	182
Bagatelle à manettes.....	U3B	126	Le II by Alberto Pinto.....	U2A	170	Profil onyx noir à manettes.....	A6P	183
Bagatelle cristal.....	U3C	129	Le II by Alberto Pinto à manettes.....	U2B	172	Pure.....	G04	192
Bagatelle pierre noire.....	U3E	128	Le II by Alberto Pinto bec cascade*.....	U2A	288	So.....	U2K	174
Bagatelle pierre noire à manettes.....	U3F	128	Malmaison Bianca Carrara*.....	U96	272	Spirit.....	G69	230
Bambou cristal ambre.....	A34	47	Malmaison cristal*.....	U94	270	Spirit à manettes.....	G58	232
Bambou cristal clair.....	A35	44	Malmaison métal*.....	U93	268	Sully jaspé rouge.....	A1X	149
Bambou cristal noir.....	A33	46	Malmaison Portoro*.....	U95	273	Sully lapis lazuli.....	A1W	149
Beluga.....	G1T	188	Mandarine cristal clair.....	U1D	208	Sully malachite.....	A1V	149
Beluga à manettes.....	G1U	190	Mandarine cristal clair satiné.....	U1E	209	Sully onyx blanc.....	U1S	148
Beverly.....	J17	224	Mandarine cristallia diamant.....	U1K	212	Sully onyx noir.....	U1T	149
Broadway.....	A52	260	Mandarine métal.....	U1A	206	Sun Dragon.....	U5D	76
Broadway à manettes.....	A04	262	Marina métal.....	A61	184	Tête de Lion.....	G99	280
Capucine mauve.....	A7D	114	Marina onyx noir.....	A60	186	Tradition.....	A57	254
Capucine vert.....	A7E	110	Marquise doré.....	A7F	98	Tradition à manettes.....	A58	256
Charleston.....	G29	242	Marquise platine.....	A7G	94	Tradition cristal.....	A59	258
Charleston à manettes.....	G75	246	Masque de femme lunaire.....	A2R	52	Trocadéro jaspé rouge.....	U7C	140
Cheverny jaspé rouge.....	A1U	149	Masque de femme métal gravé.....	A2T	50	Trocadéro lapis lazuli.....	U7B	140
Cheverny lapis lazuli.....	A1T	144	Masque de femme métal lisse.....	A2U	48	Trocadéro malachite.....	U7A	140
Cheverny malachite.....	A1S	147	Masque de femme solaire.....	A2S	54	Trocadéro œil de tigre.....	U7E	138
Cheverny onyx noir.....	U1V	145	Métropolis cristal clair.....	A2A	40	Trocadéro onyx noir.....	U7D	140
Collection O*.....	G4P	156	Métropolis à manettes.....	A2B	43	Urban.....	A39	292
Cubica.....	G79	226	Métropolis à manettes cristal noir.....	A2M	42	Vasques métal.....	GB2	304
Cygne.....	G31	276	Métropolis cristal noir.....	A2L	40	Vegetal.....	U5F	88
Diplomate bagues annelées.....	U4B	218	Moon Dragon.....	U5G	78	Vendôme.....	G47	228
Diplomate bagues lisses.....	U4A	216	Mossi cristal clair.....	A2N	68	Venice.....	A2E	64
Diplomate bagues torsadées.....	U4C	220	Naiade.....	A2F	70	Versailles.....	G14	278
Diplomate Royale.....	U4D	222	Najem.....	E53	214	Vogue améthyste.....	A8B	130
Duomo.....	U4E	150	Nano*.....	G5A	160	Vogue jaspé rouge.....	A8N	132
Duomo cristal.....	U4F	152	Nano à manettes*.....	G5B	162	Vogue lapis lazuli.....	A8S	132
Ellipse.....	A44	294	Niagara.....	A38	290	Vogue malachite.....	A8M	132
Faubourg métal.....	G2T	204	Océania.....	A2C	66	Vogue œil de tigre.....	A8R	132
Faubourg métal à manettes.....	G2U	204	Panthère cristal clair.....	A2H	36	Vogue onyx noir.....	A8P	132
Faubourg porcelaine blanche.....	G2K	200	Panthère cristal noir.....	A2K	37			
Faubourg porcelaine blanche à man. ....	G2J	200	Papillon.....	A2J	60			

# Index alphanumérique

## Alphanumeric index

## Alphanumerischen Übersicht

Code	Series	Page	Code	Series	Page	Code	Series	Page
AIM.....	Amboise onyx noir	143	A6P.....	Profil onyx noir à manettes	183	G99.....	Tête de Lion	280
A04.....	Broadway à manettes	262	A7A.....	Ithaque doré	106	GB2.....	Vasques métal	304
A1J.....	Amboise malachite	143	A7B.....	Ithaque platine	102	J17Beverley.....	224	
A1K.....	Amboise lapis lazuli	143	A7D.....	Capucine mauve	114	U1A.....	Mandarine métal	206
A1L.....	Amboise jaspe rouge	142	A7E.....	Capucine vert	110	UID.....	Mandarine cristal clair	208
A1S.....	Chevigny malachite	147	A7F.....	Marquise doré	98	UIE.....	Mandarine cristal clair satiné	209
A1T.....	Chevigny lapis lazuli	144	A7G.....	Marquise platine	94	UIK.....	Mandarine cristallia diamant	212
A1U.....	Chevigny jaspe rouge	149	A7L.....	Poèmes	120	UIS.....	Sully onyx blanc	148
A1V.....	Sully malachite	149	A8B.....	Vogue améthyste	130	UIT.....	Sully onyx noir	149
A1W.....	Sully lapis lazuli	149	A8M.....	Vogue malachite	132	UIV.....	Chevigny onyx noir	145
A1X.....	Sully jaspe rouge	149	A8N.....	Vogue jaspe rouge	132	U2A.....	Le II by Alberto Pinto	170
A2A.....	Métropolis cristal clair	40	A8P.....	Vogue onyx noir	132	U2A.....	Le II by Alberto Pinto bec cascade*	288
A2B.....	Métropolis à manettes	43	A8R.....	Vogue œil de tigre	132	U2B.....	Le II by Alberto Pinto à manettes	172
A2C.....	Océania	66	A8S.....	Vogue lapis lazuli	132	U2K.....	So	174
A2E.....	Venice	64	A9B.....	Jaipur cristal satiné	137	U3A.....	Bagatelle	126
A2F.....	Naiade	70	A9C.....	Jaipur onyx noir	136	U3B.....	Bagatelle à manettes	126
A2G.....	Ange	62	A9F.....	Jaipur métal	134	U3C.....	Bagatelle cristal	129
A2H.....	Panthère cristal clair	36	E53.....	Najem	214	U3E.....	Bagatelle pierre noire	128
A2i.....	Perle bec cascade*	284	G00.....	Accessoires Tous Styles	306	U3F.....	Bagatelle pierre noire à manettes	128
A2i.....	Perle*	72	G04.....	Pure	192	U4A.....	Diplomate bagues lisses	216
A2j.....	Papillon	60	G08.....	Pompadour	264	U4B.....	Diplomate bagues annelées	218
A2K.....	Panthère cristal noir	37	G14.....	Versailles	278	U4C.....	Diplomate bagues torsadées	220
A2L.....	Métropolis cristal noir	40	G17.....	Beluga	188	U4D.....	Diplomate Royale	222
A2M.....	Métropolis à manettes cristal noir	42	G1U.....	Beluga à manettes	190	U4E.....	Duomo	150
A2N.....	Mossi cristal clair	68	G24.....	Amour de Trianon	274	U4F.....	Duomo cristal	152
A2R.....	Masque de femme lunaire	52	G25.....	1900	236	U5A.....	Flore	86
A2S.....	Masque de femme solaire	54	G28.....	1900 à manettes	240	U5B.....	Island	82
A2T.....	Masque de femme métal gravé	50	G29.....	Charleston	242	U5C.....	Paradise	84
A2U.....	Masque de femme métal lisse	48	G2J.....	Faubourg porcelaine blanche à man.	200	U5D.....	Sun Dragon	76
A33.....	Bambou cristal noir	46	G2K.....	Faubourg porcelaine blanche	200	U5E.....	Ginkgo	90
A34.....	Bambou cristal ambre	47	G2L.....	Faubourg porcelaine noire	202	U5F.....	Vegetal	88
A35.....	Bambou cristal clair	44	G2M.....	Faubourg porcelaine noire à man.	202	U5G.....	Moon Dragon	78
A38.....	Niagara	290	G2N.....	Froufrou	198	U5H.....	Jade Dragon	80
A39.....	Urban	292	G2P.....	Froufrou à manettes	199	U6A.....	Pétale de cristal clair*	24
A44.....	Ellipse	294	G2R.....	Frivole	196	U6B.....	Pétale de cristal bleu*	30
A52.....	Broadway	260	G2S.....	Frivole à manettes	196	U6C.....	Pétale de cristal rouge*	28
A54.....	Art Déco	248	G2T.....	Faubourg métal	204	U6D.....	Pétale de cristal noir*	32
A55.....	Art Déco à manettes	250	G2U.....	Faubourg métal à manettes	204	U6E.....	Pétale de cristal liseré doré*	26
A56.....	Art Déco cristal	252	G31.....	Cygne	276	U7A.....	Trocadéro malachite	140
A57.....	Tradition	254	G47.....	Vendôme	228	U7B.....	Trocadéro lapis lazuli	140
A58.....	Tradition à manettes	256	G4P.....	Collection O*	156	U7C.....	Trocadéro jaspe rouge	140
A59.....	Tradition cristal	258	G58.....	Spirit à manettes	232	U7D.....	Trocadéro onyx noir	140
A60.....	Marina onyx noir	186	G5A.....	Nano*	160	U7E.....	Trocadéro œil de tigre	138
A61.....	Marina métal	184	G5B.....	Nano à manettes*	162	U93.....	Malmaison métal*	268
A6A.....	Profil métal	181	G5C.....	Anoa corne claire*	164	U94.....	Malmaison cristal*	270
A6B.....	Profil métal à manettes	178	G5D.....	Anoa corne noire*	168	U95.....	Malmaison Portoro*	273
A6G.....	Profil cristal clair	56	G69.....	Spirit	230	U96.....	Malmaison Bianca Carrara*	272
A6H.....	Profil cristal clair à manettes	58	G75.....	Charleston à manettes	246			
A6N.....	Profil onyx noir	182	G79.....	Cubica	226			

# Label EPV

*EPV label*

EPV Gütesiegel

EPV, la garantie d'un savoir-faire rare et exceptionnel...

*EPV, the guarantee of rare and exceptional know-how...*

EPV, die Garantie für ein ausgefallenes und außergewöhnliches Know-how...



En 2012, THG a reçu le prestigieux label EPV (entreprise du patrimoine vivant), marque de reconnaissance du ministère de l'Economie, des Finances et de l'Industrie. L'entreprise rejoint ainsi les rangs de plusieurs centaines d'entreprises distinguées pour leur savoir-faire rare, symbolique de l'excellence française.

*THG has been awarded in 2012 the prestigious French "EPV" quality label (a "living heritage company"), a recognition by the French Ministry of Economy, Finance and Industry. The company joins the few hundred companies that have been recognized for their rare savoir-faire as a symbol of French excellence.*



THG Paris wurde erst kürzlich mit dem begehrten Gütesiegel "Entreprise du Patrimoine Vivant", EPV, ausgezeichnet. Das Siegel wird in Frankreich vom Ministerium für Wirtschaft, Finanzen und Industrie verliehen. Es honoriert das einzigartige Savoir-faire von THG Paris, die hervorragende Qualität, lebendiges Handwerk und damit französisches Kulturgut.

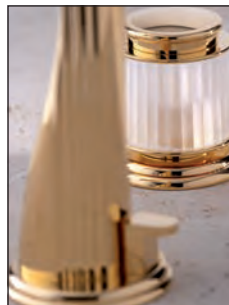





# Références hôtels

*Hotel references*

Hotel Referenzen

## Austria

Alpenschlössl (Steinhaus)  
Tiefenbrunner (Kitzbühel)

## Belgium

Die Swaene Hotel (Bruges)  
Le Plaza (Brussels)

## China

Havana Grand Hotel (Shanghai)  
Pangu (Beijing)  
Peninsula (Shanghai)  
Sanya Phoenix Island (Hainan)  
Shimao (Shanghai)  
Star River (Guangzhou)  
Star River (Shanghai)

## Egypt

Saudi Arabia embassy (Cairo)  
Sofitel Cataract (Aswan)

## France

Banville (Paris)  
Château des Vigiers (Bergerac)  
Château du Cheval Blanc (Saint Emilion)  
Château Lafitte Rothschild (Pauillac)  
Crillon (Paris)  
Daniel (Paris)  
Hilton (Paris)  
Intercontinental (Paris)  
Jiva Hill Park Hotel (Crozet)  
Keppler (Paris)  
K2 (Courchevel)  
La Maison de Lucie (Honfleur)  
La Trémoille (Paris)  
Le Bristol (Paris)  
Le Cheval Blanc (Courchevel)  
Le Cise (Ault)  
Le Fouquet's (Paris)  
Le Manoir (Paris)  
Le Pradey (Paris)  
Le Puy du Fou (Les Epesses)  
Le Relais de Margaux (Margaux)  
Le Scribe (Paris)

Les 3 vallées (Courchevel)  
Les Aiglons (Chamonix)  
Les Crayères (Reims)  
L'Esprit Saint-Germain (Paris)  
Normandy Barrière (Deauville)  
Pan Deï Palais (Saint-Tropez)  
Plaza Athénée (Paris)  
Princesse de Megève (Megève)  
Ritz (Paris)  
Royal Barrière (Deauville)  
Saint James (Bouliac)  
Shangri-La (Paris)  
Spa du Grand Hôtel Barrière (Enghien-les-Bains)  
Terre Blanche (Fayence)  
Tonic Hôtel (Biarritz)  
Villa d'O (Bordeaux)  
Westminster (Le Touquet)

## Greece

Pentelikon (Athens)  
Sofitel Airport (Athens)

## Italia

Four Seasons (Firenze)

## Korea

Samsung Tower (Seoul)

## Monaco

L'Hermitage  
Monte Carlo Bay  
Prince de Galles

## Morocco

Amanjena (Marrakech)  
Hôtel Barrière (Marrakech)  
La Mamounia (Marrakech)  
Malabata (Tangier)  
Michilifen (Ifrane)

## Oman

Al Bustan Palace (Muscat)

## Poland

Rialto Hotel (Warsaw)

## Spain

Aloha Park (Marbella)  
Laguna de Banus (Marbella)

## Switzerland

Hôtel des Bergues (Genève)  
Hôtel du Lac (Vevey)

## Tunisia

Hilton (Tunis)  
Africa hotel (Tunis)  
Hasdrubal (Hammamet)

## Turkey

Marmara (Istanbul)  
Safisa Hotel (Antalya)

## UAE

Atlantis (Dubai)  
Burj Al Arab (Dubai)  
Emirates Palace (Abu Dhabi)  
Grand Hyatt (Dubai)  
Jumeirah Beach (Dubai)  
Marriott (Dubai)

## United Kingdom

Chewton Glenn Hotel (Hampshire)  
Claridges Hotel (London)  
Dukes Hotel (London)  
Gidleigh Park Hotel (Devon)  
Greenwoods Hotel & Spa (Stock)  
Le Manoir aux quat' saisons (Oxford)  
Stapleford Park Hotel (Leicestershire)  
The Dorchester (London)  
The Grove Hotel (Rickmansworth)  
Wentworth Golf Club (Surrey)

## USA

Bellagio (Las Vegas)  
Caesars Palace (Las Vegas)  
Casino (Las Vegas)  
One Hanson Place (New York)  
Wynn Resort (Las Vegas)  
The Trump Taj Mahal Hotel (Las Vegas)



Africa  
Africa Queen  
Al Bravo  
Al Salamah  
Alfa IV  
Allegro  
Amevi  
Amnesia

Amnesia II  
Aria  
Atlantide  
Azzam  
Brave Love I  
Bun Bun  
Cakewalk  
Capri

Carinthia VII  
Cedar Sea II  
Coral Island  
Delphine  
Diamonds are Forever  
Domani  
Eliza jean  
G Force

Galaxy  
Illusion  
Jazz of Monaco  
Katana  
Lady Haya  
Lady Moura  
Limitless  
Lionheart

# Références yachting

*Yachting references*  
Yachten Referenzen



Mamma mia  
Mariah II  
Mi Gaea  
Mi Sueno  
More  
Netanya VII  
Netanya VIII  
Norwegian Queen

Octopus  
O'Mega  
Passion  
Patricia  
Pelorus  
Perfect Prescription  
Prince Abdul Aziz  
Princesse Mariana

Quatroelle  
Queen M  
Regina d'Italia  
Silver Angel  
Skat  
Slipstream  
Smile  
Solandge

Squall  
Sunflower  
Sycara IV  
Tigre d'Or  
Victory  
Vinydrea  
Xanadu  
Zenobia

# Partenaires

Partners / Partner

## BERNARDAUD



Porcelainier d'exception... *Exceptional porcelain-maker...*

Der Ausnahme-Porzellanhersteller ...

Symbole de la tradition et du luxe, BERNARDAUD incarne l'une des références les plus novatrices du savoir-faire français. Née d'un savoir-faire artisanal profondément ancré dans la tradition française, l'alliance THG et Bernardaud célèbre le luxe sous toutes les formes d'un art sans cesse renouvelé.

*A symbol of tradition and luxury, BERNARDAUD embodies one of the most innovative forms of French know-how. The result of craft expertise profoundly steeped in French tradition, the alliance of THG and Bernardaud celebrates luxury in all its forms with constantly renewed artistry.*

Das Bündnis zwischen THG und Bernardaud gründet auf einem tief in der französischen Tradition verwurzelten handwerklichen Können und steht im Zeichen einer neuen Kunst in all ihren Formen.

## LALIQUE



Sculpteur de lumière... *Light sculptor...* Skulptur des Lichts ...

Depuis 2002, THG, célèbre robinetier de style français et LALIQUE, manufacture emblématique d'objets en cristal, ont uni leurs savoir-faire respectifs afin de proposer une gamme luxueuse et raffinée de robinetteries, d'accessoires, de boutons de meuble et de poignées de porte.

*Since 2002, THG, renowned French fittings manufacturer and LALIQUE the symbolic factory for crystal items, have combined their expertise to offer a luxurious and refined range of fittings, accessories, cabinet knobs and door handles.*

Seit 2002 entwickeln der renommierte Armaturenhersteller aus Frankreich, THG und Lalique, das Sinnbild für Kristallerzeugnisse, mit ihrem Fachwissen luxuriöse und veredelte Kollektionen von THG: Armaturen, Accessoires sowie Schrank- und Türgriffe.

## Daum



L'Art est le luxe ultime... *Art is the ultimate luxury...*

Die Kunst ist der ultimative Luxus...

Daum, maître-verrier légendaire, entretient depuis plus d'un siècle une relation d'amour avec les plus grands artistes de son temps. Ainsi, Daum a associé son savoir-faire à celui de THG pour créer une collection inédite.

*Daum, the legendary glassmaker master, has kept alive for more than a century a love relationship with the greatest artists of its time. Thus, Daum has combined its expertise to THG's to present a brand new collection of luxurious taps.*

Vor mehr als einem Jahrhundert begann der legendäre Glasmeister Daum, Beziehungen zu den größten Künstlern seiner Zeit aufzubauen. Mit vereintem Know-how haben Daum und der französische Hersteller von Luxusarmaturen THG eine Kollektion ohnegleichen geschaffen.

# Partenaires

## Partners / Partner

*Baccarat*

Tradition et excellence...

*Heritage and excellence...* Tradition und Erstklassigkeit...



Entre la magie et la fascination, le destin de Baccarat s'écrit en lettres étincelantes, empreinte d'une ancestrale modernité.

La collection « Pétale de Cristal », dessinée par Pierre-Yves Rochon, est l'association originale des savoir-faire de la Maison Baccarat et de THG.

*Between magic and fascination, its fabulous destiny is written in sparkling letters and imbued with ancestral modernity.*

*The "Pétale de Cristal" collection, designed by Pierre-Yves Rochon, is the original combination of the know-how of the Maison Baccarat and THG.*

Baccarat steht dabei für Magie und Faszination von hochwertigem Kristall, für exzellentes handwerkliches Können und eine traditionsreiche Modernität. In der Kollektion „Pétale de cristal“, entworfen von Pierre-Yves Rochon, verschmelzen die Kompetenz der Manufaktur Baccarat und die Kompetenz von THG.



*Christofle*  
PARIS

L'orfèvrerie de prestige... *Prestigious silversmith...*

Eine Silberschmiede von Weltruhm...



De l'ultracontemporain au baroque, les créations de Christofle transportent l'essence de l'Art de Vivre à la française. Sublimier le métal, telle est la marque de fabrique de Christofle et de THG. C'est donc tout naturellement que les deux Maisons ont uni leur savoir-faire pour créer des lignes de robinetteries de style uniques et d'une élégance incomparable.

*Ultra-contemporary to baroque, Christofle's creations spread the essence of French "Art de Vivre". Sublimation of metal is their trademark, it is naturally that THG and Christofle united their know-how to create lines of unique and stylish taps lines.*

Von Design auf der Höhe der Zeit bis Barock, die traditionsreiche Silberschmiede Christofle bringt immer auch französisches Art de Vivre zum Ausdruck. Christofle und THG Paris vereinen die Expertise, Metall zu veredeln. Ein Grund mehr, dass sich die beiden Unternehmen mit ihrem Savoir-faire zusammengetan haben, um Armaturen von einzigartigem Stil und unvergleichbarer Eleganz herzustellen.

# Designers

Designers / Designer

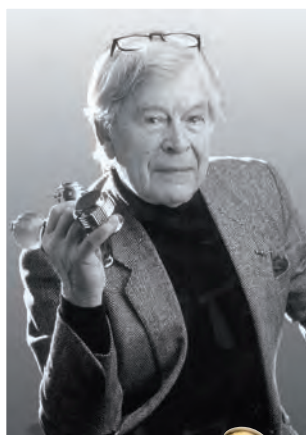

Des créateurs de talent... *Talented creators...* Begnadete Designer...

Depuis sa première collaboration avec Jean-Claude Delépine, THG n'a eu de cesse de créer de nouvelles lignes de robinetterie aux styles uniques. Pour y parvenir, elle a su s'entourer de grands artistes qui ont réussi à marquer de leur empreinte de simples objets usuels et les transformer en de véritables chef-d'œuvres.

*Since its first collaboration with Jean-Claude Delépine, THG has continued to create new tap lines in unique styles. To achieve this goal, the company has collaborated with great artists who have managed to make their mark on simple objects and transform them into true masterpieces.*

Seitdem Jean-Claude Delépine zum ersten Mal mit THG zusammen gearbeitet hatte, schuf er fortwährend neue Armaturenserien in seinem unvergleichlichen Stil. Seitdem versteht es THG, mit großen Künstlern zusammen zu arbeiten, welche es immer wieder schaffen, einfache Gebrauchsgegenstände in wahrhafte Meisterwerke zu verwandeln.

# Designers

*Designers / Designer*



OLIVIER  
GAGNERE



AP  
ALBERTO PINTO



O.  
ogossart



STUDIO PUTMAN

Scannez ces QR codes pour découvrir nos partenaires et designers !

*Scan those QR Code to discover our partners and designers!*

Scannen Sie den QR-Codes, um unsere Partner und Designer kennenzulernen !



Partenaires  
Partners  
Partner



Designers  
Designers  
Designer





# Baccarat



Pétale de Cristal  
clair . 24  
clair liseré doré . 26  
rouge . 28  
bleu . 30  
noir . 32



**Ref. U6A.2155**  
 Mélangeur de lavabo monotrou  
 One hole basin mixer  
 1-Loch-Zweigriff -Waschtischbatterie



**Ref. U6A.41SG**  
 Mélangeur de bain 3 trous mural  
 Wall mounted 3-hole bath mixer  
 3-Loch-Wannenfüllbatterie zur Wandmontage



**Ref. U6A.3202**  
 Mélangeur de bidet  
 One hole bidet mixer  
 1-Loch-Zweigriff - Bidetbatterie



**Ref. U6A.5500B**  
 Garniture pour mitigeur thermostatique  
 avec inverseur 2 sorties  
 Trim for THG thermostat with 2-way diverter  
 Thermostat-Garnitur mit Temperatureinstellung mit  
 Absperr- und Umstellfunktion



**Ref. U6A.504N**  
 Anneau porte-serviette  
 Single towel ring  
 Handtuchring

# Pétale de Cristal clair

by  
  
CREATIONS  
Jean-Claude HEUPFINGER  
PARIS



**Ref. U6A.151**  
Mélangeur de lavabo 3 trous  
3-hole basin mixer  
3-Loch-Waschtischbatterie

Design Pierre-Yves ROCHON

*Baccarat* 25 

# Pétale de Cristal

*liseré doré*

by   
 CREATONS  
 Jean-Charles FREZZONE  
 PARIS



**Ref. U6E.1132SG**

Mélangeur de bain avec douchette alimentée par mitigeur  
 Bath mixer + handshower set with single lever mixer  
 Wannenbatterie mit 1-Loch-Einhandmischer mit Brausegarnitur

**Ref. U6E.5400B**

Garniture pour mitigeur thermostatique  
 avec 2 robinets d'arrêt  
 Trim for THG thermostat with 2 valves  
 Thermostat-Garnitur mit 2 Absperrungen



**Ref. U6E.151**

Mélangeur de lavabo 3 trous  
 3-hole basin mixer  
 3-Loch-Waschtischbatterie



**Ref. U6E.52**

Ensemble de douche  
 Shower set  
 Duschkombination



**Ref. U6E.546GM**

Coupe porte-savon  
 Soap dish  
 Wandseifenschale



*Baccarat* 27

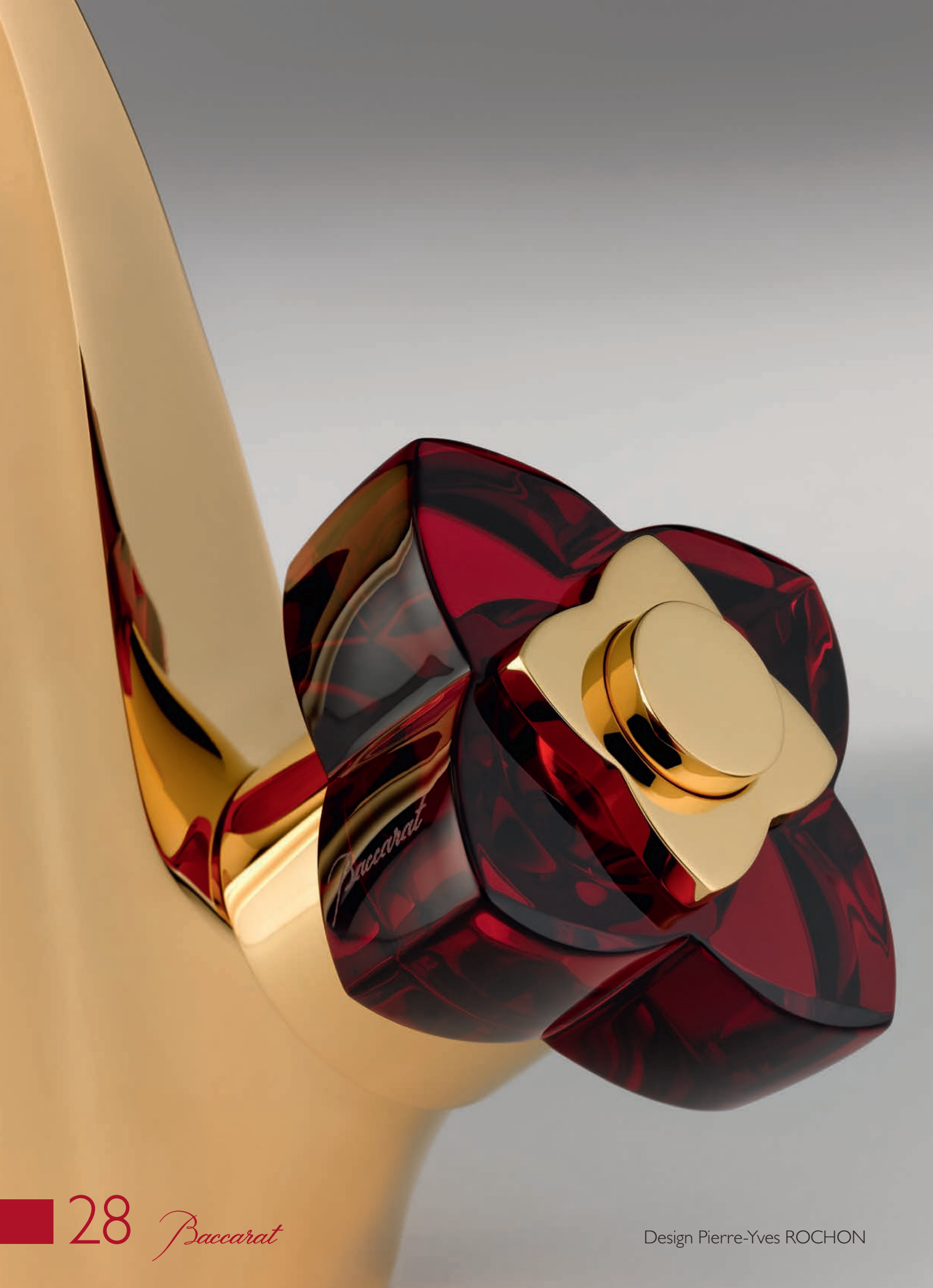

28 *Baccarat*

Design Pierre-Yves ROCHON

# Pétale de Cristal rouge

by  
**FS**  
CREATIONS  
Jean-Claude DELFÈVE  
PARIS



**Ref. U6C.151**  
Mélangeur de lavabo 3 trous  
3-hole basin mixer  
3-Loch-Waschtischbatterie



**Ref. U6C.40G**  
Mélangeur de lavabo 3 trous mural  
Wall mounted basin set  
3-Loch-Waschtischbatterie zur Wandmontage



**Ref. U6C.2155**  
Mélangeur de lavabo monotrou  
One hole basin mixer  
1-Loch-Zweigriff -Waschtischbatterie



**Ref. U6C.3202**  
Mélangeur de bidet  
One hole bidet mixer  
1-Loch-Zweigriff -Bidetbatterie



**Ref. U6C.517**  
Porte-peignoir  
Single robe hook  
Bademantelhalter



**Ref. U6C.514**  
Porte-serviette  
Single towel rail  
Handtuchstange





**Ref. U6B.1132SG**

Mélangeur de bain avec douchette alimentée par mitigeur  
 Bath mixer + handshower set with single lever mixer  
 Wannensbatterie mit 1-Loch-Einhandmischer mit Brausegarnitur



**Ref. U6B.49/3/VM**

Inverseur mural 3 sorties  
 Wall mounted 3-diverter  
 Unterputz-3-Wege-Umstellventil



**Ref. U6B.5840/8**

Ensemble hygiénique  
 Hygienic set  
 Toilettenspülgarnitur



**Ref. U6B.4720C**

Ensemble pot à balai  
 WC brush set  
 WC-Bürstentopf-garnitur



**Ref. U6B.500**

Porte-savon  
 Soap dish  
 Seifenschale

# Pétale de Cristal

bleu

by  
  
CREATIONS  
Jean-Claude HEFFENE  
PARIS



**Ref. U6B.151**

Mélangeur de lavabo 3 trous  
3-hole basin mixer  
3-Loch-Waschtischbatterie

Design Pierre-Yves ROCHON

*Baccarat* 31 



**Ref. U6D.500**  
Porte-savon  
Soap dish  
Seifenschale



**Ref. U6D.536**  
Porte-verre  
Tumbler  
Wandglashalter mit Glas



**Ref. U6D.517**  
Porte-peignoir  
Single robe hook  
Bademantelhalter

# Pétale de Cristal noir

by  
**CS**  
CREATIONS  
Jean-Claude DIEZELLE  
PARIS



**Ref. U6D.151**  
Mélangeur de lavabo 3 trous  
3-hole basin mixer  
3-Loch-Waschtischbatterie



**Ref. U6D.41SG**  
Mélangeur de bain 3 trous mural  
Wall mounted 3-hole bath mixer  
3-Loch-Wannenfüllbatterie zur Wandmontage



**Ref. U6D.5500B**  
Garniture pour mitigeur thermostatique  
avec inverseur 2 sorties  
Trim for THG thermostat with 2-way diverter  
Thermostat-Garnitur mit Temperatureinstellung mit  
Absperr- und Umstellfunktion



**Ref. U6D.504N**  
Anneau porte-serviette  
Single towel ring  
Handtuchring



# LALIQUE



Panthère . 36  
Métropolis . 40  
Bambou . 44  
Masque de femme . 48  
Profil Lalique . 56  
Papillon . 60

Ange . 62  
Venice . 64  
Oceania . 66  
Mossi . 68  
Naiade . 70  
Perle . 72



**Ref. A2H.151**

Mélangeur de lavabo 3 trous - Cristal clair  
Rim mounted 3-hole basin mixer - Clear crystal  
3-Loch-Waschtischbatterie - Klarer Kristall

36 LALIQUE

# Panthère

design   
CREATIONS  
Jean-Claude CALZADINI  
PARIS



**Ref. A2K.151**

Mélangeur de lavabo 3 trous - Cristal noir  
Rim mounted 3-hole basin mixer - Black crystal  
3-Loch-Waschtischbatterie - Schwarzer Kristall

LALIQUE 37





# Panthère

design   
CREATIONS  
Jewelry - Crystal - 181219102  
1932



**Ref. A2H.546GM**

Coupe murale - Cristal clair  
Wall mounted soap dish - Clear crystal  
Wandseifenschale - Klarer Kristall



**Ref. A2H.504N**

Anneau-porte serviette - Cristal clair  
Single towel ring - Clear crystal  
Handtuchring - Klarer Kristall





**Ref. A2A.504N**

Anneau-porte serviette - Cristal clair  
Single towel ring - Clear crystal  
Handtuchring - Klarer Kristall



**Ref. A2A.620**

Porte-savon fil mural - Cristal clair  
Net soap dish - Clear crystal  
Wandseifenkorb - Klarer Kristall



**Ref. A2A.151**

Mélangeur de lavabo 3 trous - Cristal clair  
Rim mounted 3-hole basin mixer - Clear crystal  
3-Loch-Waschtischbatterie - Klarer Kristall



**Ref. A2L.151**

Mélangeur de lavabo 3 trous - Cristal noir  
Rim mounted 3-hole basin mixer - Black crystal  
3-Loch-Waschtischbatterie - Schwarzer Kristall

# Métropolis

design   
CREATIONS  
Journé - Claude BÉGIN  
PARIS





**Ref. A2M.151**

Mélangeur de lavabo 3 trous - Cristal noir  
 Rim mounted 3-hole basin mixer - Black crystal  
 3-Loch-Waschtischbatterie - Schwarzer Kristall



**Ref. A2L.620**

Porte-savon fil mural  
 cristal noir  
 Net soap dish  
 black crystal  
 Wandseifenkorb  
 Schwarzer Kristall



**Ref. A2L.66**

Douchette droite 1/2" anti-calcaire  
 Handshower 1/2", hard water protection  
 Handbrause 1/2" mit Antikalksystem



# Métropolis à manettes

design  
  
CREATIONS  
Jean Charles LALIQUE  
PARIS



**Ref. A2B.151**

Mélangeur de lavabo 3 trous - Cristal clair  
Rim mounted 3-hole basin mixer - Clear crystal  
3-Loch-Waschtischbatterie - Klarer Kristall



**Ref. A2B.5100B**

Garniture pour mitigeur  
thermostatique - Cristal clair  
Trimmings for thermostat - Clear crystal  
Thermostat-Garnitur - Klarer Kristall



**Ref. A2B.514**

Porte-serviette - Cristal clair  
Single towel rail - Clear crystal  
Handtuchstange - Klarer Kristall







**Ref. A35.25SG**

Mélangeur de bain 3 trous sur gorge - Cristal clair  
Rim mounted 3-hole bath mixer - Clear crystal  
3-Loch-Wannenfüllbatterie zur Standmontage - Klarer Kristall

**Ref. A35.6523/60A**

Mitigeur sur gorge et douchette - Cristal clair  
Rim mounted ceramic mixer and handshower - Clear crystal  
Einhandmischer mit Brausegarnitur zur Standmontage - Klarer Kristall



# Bambou

design  
  
CREATIONS  
Journé - Capitale 181221010  
71625



**Ref. A33.151**

Mélangeur de lavabo 3 trous - Cristal noir  
Rim mounted 3-hole basin mixer - Black crystal  
3-Loch-Waschtischbatterie - Schwarzer Kristall



**Ref. A35.6500**

Mitigeur de lavabo - Cristal clair  
Single lever basin mixer - Clear crystal  
Waschtisch-Einhebelmischer - Klarer Kristall



**Ref. A35.151**

Mélangeur de lavabo 3 trous - Cristal clair  
Rim mounted 3-hole basin mixer - Clear crystal  
3-Loch-Waschtischbatterie - Klarer Kristall

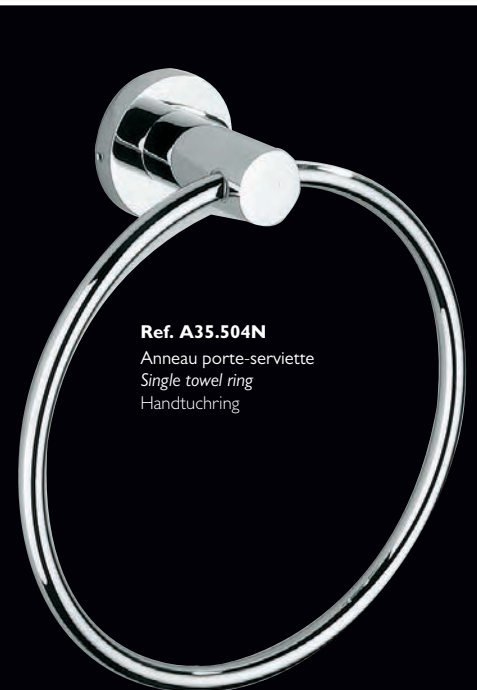

**Ref. A35.504N**

Anneau porte-serviette  
Single towel ring  
Handtuchring

**Ref. A34.151**

Mélangeur de lavabo 3 trous - Cristal ambre  
Rim mounted 3-hole basin mixer - Amber crystal  
3-Loch-Waschtischbatterie - Bernsteinfarbener Kristall



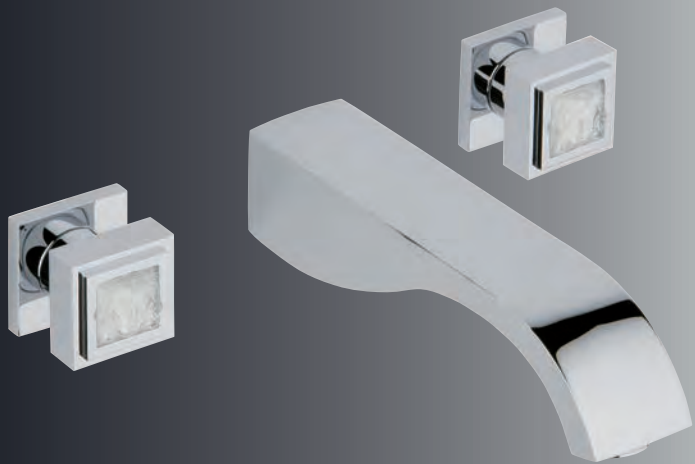

**Ref. A2U.41SG**

Mélangeur de bain 3 trous mural  
Wall mounted 3-hole bath mixer  
Wannenbatterie zur Wandmontage



**Ref. A2U.514**

Porte-serviette  
Single towel rail  
Handtuchstange



**Ref. A2U.536**

Porte-verre mural  
Wall mounted tumbler  
Wandglashalter mit Glas



# Masque de femme

*métal lisse*

design  
  
CREATIONS  
Jean-Claude LALIQUE  
PARIS



**Ref. A2U.151**

Mélangeur de lavabo 3 trous  
*Rim mounted 3-hole basin mixer*  
3-Loch-Waschtischbatterie

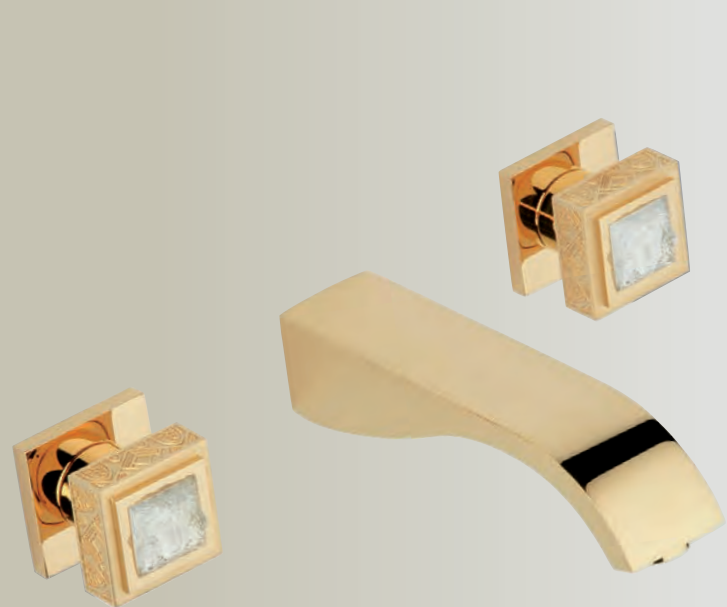

**Ref. A2T.40G**

Mélangeur de lavabo 3 trous mural  
Wall mounted 3-hole basin mixer  
3-Loch-Waschtischbatterie zur Wandmontage



**Ref. A2T.546GM**

Coupe murale  
Wall mounted soap dish  
Wandseifenschale



**Ref. A2T.504N**

Anneau porte-serviette  
Single towel ring  
Handtuchring



# Masque de femme

*métal gravé*

design  
  
CREATIONS  
Jean-Claude LALIQUE  
PARIS



**Ref. A2T.151**  
Mélangeur de lavabo 3 trous  
*Rim mounted 3-hole basin mixer*  
3-Loch-Waschtischbatterie

# Masque de femme *lunaire*

design  
  
CREATIONS  
Jean-Claude CALZADINI  
PARIS



**Ref. A2R.151**

Mélangeur de lavabo 3 trous  
*Rim mounted 3-hole basin mixer*  
3-Loch-Waschtischbatterie



**Ref. G00.280C**

Pomme de douche 300 x 300 mm  
Shower head 300 x 300 mm / 11 3/4" x 11 3/4"  
Brausekopf 300 x 300 mm



**Ref. A2R.5100B**

Garniture pour mitigeur thermostatique  
Trimings for thermostat  
Thermostat-Garnitur



**Ref. A2R.504N**

Anneau porte-serviette  
Single towel ring  
Handtuchring



**Ref. A2R.151**

Mélangeur de lavabo 3 trous  
Rim mounted 3-hole basin mixer  
3-Loch-Waschtischbatterie





54 LALIQUE

# Masque de femme solaire

design  
  
CREATIONS  
Jean-Claude LALIQUE  
PARIS



**Ref. A2S.151**

Mélangeur de lavabo 3 trous  
Rim mounted 3-hole basin mixer  
3-Loch-Waschtischbatterie



# Profil by cristal clair

CREATIONS  
Journé - Caille 18121912  
1988



Design Jamie DRAKE

LALIQUE 57

# Profil by

*cristal clair*

CREATIONS  
Jean-Claude CALZADINI  
PARIS



**Ref. A6G.151**  
Mélangeur de lavabo 3 trous  
Rim mounted 3-hole basin mixer  
3-Loch-Waschtischbatterie



**Ref. A6G.112BSG**  
Mélangeur bain-douche 4 trous  
4-hole deck bath-shower set  
4-Loch-Wannenfüll-und-brausebatterie



**Ref. A6H.151**  
Mélangeur de lavabo 3 trous  
Rim mounted 3-hole basin mixer  
3-Loch-Waschtischbatterie



**Ref. A6G.6500**  
Mitigeur de lavabo  
Single lever basin mixer  
Waschtisch-Einhebelmischer



**Ref. A6G.5500B - 54 - 84L - 281EP**  
Ensemble de douche  
Shower set with thermostat  
Duschkombination

LALIQUE 59

# Papillon

design   
CREATIONS  
Jean-Claude LALIQUE  
PARIS



**Ref. A2J.514**  
Porte-serviette  
Single towel rail  
Handtuchstange



**Ref. A2J.151**

Mélangeur de lavabo 3 trous  
Rim mounted 3-hole basin mixer  
3-Loch-Waschtischbatterie





**Ref. A2G.151**

Mélangeur de lavabo 3 trous  
Rim mounted 3-hole basin mixer  
3-Loch-Waschtischbatterie



**Ref. A2G.538AC**

Porte-papier  
Wall mounted WC paper holder  
WC-Papierhalter



**Ref. A2G.504N**

Anneau porte-serviette  
Single towel ring  
Handtuchring



LALIQUE 63



Ref. A2E.151  
Mélangeur de lavabo 3 trous  
Rim mounted 3-hole basin mixer  
3-Loch-Waschtischbatterie

# Venice

design   
CREATIONS  
Jean-Claude CALZADINI  
PARIS



LALIQUE 65



© MGM Marbles & Stones  
MGM  
Marbles and Stones  
ITALY

66 LALIQUE

Océania design   
CREATIONS  
Jewelry - Crystal - Ceramics  
PARIS



**Ref. A2C.151**

Mélangeur de lavabo 3 trous  
Rim mounted 3-hole basin mixer  
3-Loch-Waschtischbatterie

LALIQUE 67

# Mossi cristal clair

design  
  
CREATIONS  
Journé - Capitale 101210102  
11622

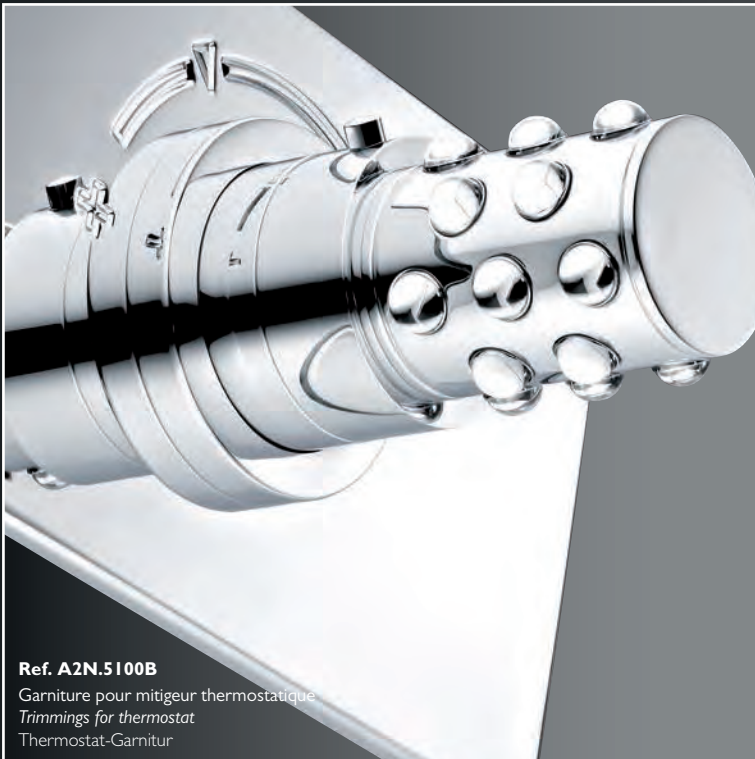

**Ref. A2N.5100B**

Garniture pour mitigeur thermostatique  
Trimmings for thermostat  
Thermostat-Garnitur



**Ref. A2N.544GM**

Coupe à poser  
Soap dish on stand  
Standseifenschale

**Ref. A2N.151**

Mélangeur de lavabo 3 trous - Cristal clair  
Rim mounted 3-hole basin mixer - Clear crystal  
3-Loch-Waschtischbatterie - Klarer Kristall





LALIQUE 69





**Ref. A2F.25SG**

Mélangeur de bain 3 trous sur gorge  
Rim mounted 3-hole bath mixer  
3-Loch-Wannenfüllbatterie zur Standmontage



**Ref. A2F.516**

Porte-serviettes 2 barres  
Double towel rails  
Handtuchstange doppelt



**Ref. A2F.504N**

Anneau porte-serviette  
Single towel ring  
Handtuchring



# Naiade

design   
CREATIONS  
Journé - Cassinè 1912/1918  
1982



**Ref. A2F.151**

Mélangeur de lavabo 3 trous  
Rim mounted 3-hole basin mixer  
3-Loch-Waschtischbatterie

LALIQUE 71



**Ref. A2i.151BP**

Mélangeur de lavabo 3 trous, bec cascade  
Rim mounted 3-hole basin mixer, waterfall spout  
3-Loch-Waschtischbatterie, Wasserfallauslauf

Perle by   
GREATONS  
 Jean Claude GILLESPIE  
 PARIS



**Ref. A2i.5400B + 54**

Garniture pour mitigeur thermostatique  
 + ensemble de douche  
*Trimmings for thermostat  
 + shower set*  
 Garnitur für THG-UP-Thermostat  
 + Duschkombination

**Ref. A2i.546**

Coupe murale  
 Wall mounted soap dish  
 Wandseifenschale



**Ref. A2i.6500P**

Mitigeur de lavabo, bec cascade  
 Single lever basin mixer, waterfall spout  
 Einloch-Einhand-Waschtischmischer; Wasserfallauslauf



LALIQUE 73



**Ref. A2i.152**

Mélangeur de lavabo 3 trous, bec haut  
 Rim mounted 3-hole basin mixer with high spout  
 3-Loch-Waschtischbatterie mit hohem Auslauf



# DAUM

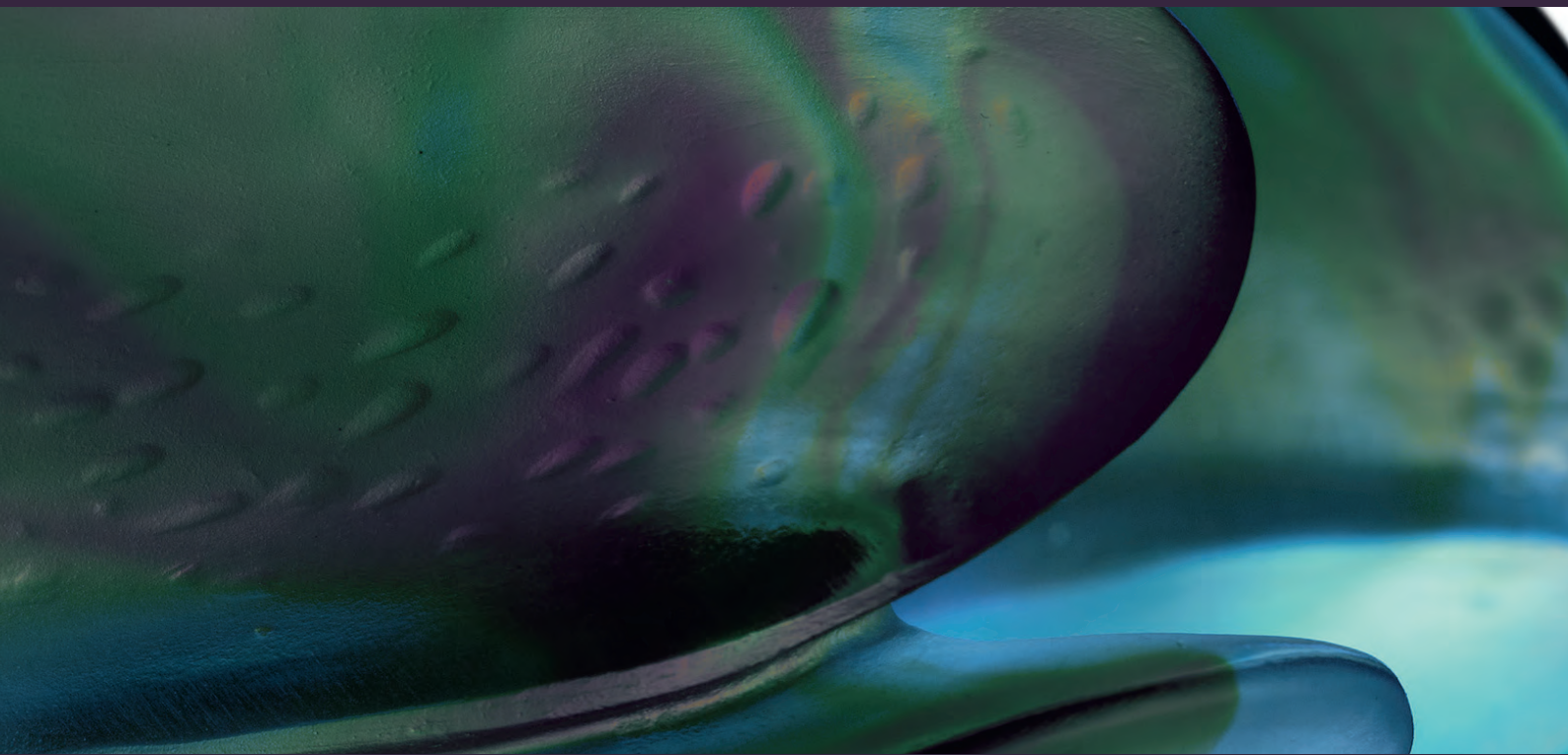

Dragon .	76
Island .	82
Paradise .	84
Flore .	86
Vegetal .	88
Ginkgo .	90



**Ref. U5D.5500B**

Garniture pour mitigeur thermostatique avec inverseur 2 sorties  
*Trim for THG thermostat with 2-way diverter*  
Thermostat-Garnitur mit 2-Wege-Umsteller

# Dragon Sun

design  
  
GREATKANS  
Jean-Claude DELLEPPE  
FLORES



**Ref. USD.151**

Mélangeur de lavabo 3 trous  
Rim mounted 3-hole basin mixer  
3-Loch-Waschtischbatterie



**Ref. USD.514**

Porte-serviette  
Single towel rail  
Handtuchstange



# Dragon Moon

design  
  
GREATKON  
Jean-Claude DELLEPPE  
1985



**Ref. USG.1132SG**

Mélangeur de bain avec douchette alimentée par mitigeur

Bath mixer + handshower set with single lever mixer

Wannenbatterie zur Standmontage mit 1-Loch-Einhandmischer mit Brausegarnitur



**Ref. USG.5840/8**

Ensemble hygiénique

Hygienic set

Toilettenspülgarnitur

78 *Daum*



**Ref. U5G.151**  
Mélangeur de lavabo 3 trous  
*3-hole basin mixer*  
3-Loch-Waschtischbatterie



**Ref. U5G.40G**  
Mélangeur de lavabo 3 trous mural  
*Wall mounted 3-hole basin mixer*  
3-Loch-Waschtischbatterie zur Wandmontage



**Ref. U5H.504N**  
Anneau porte-serviette  
Single towel ring  
Handtuchring

80 *Damm*

# Dragon Jade

design  
  
GREATON  
Jean-Claude PELLISSIER  
F1025

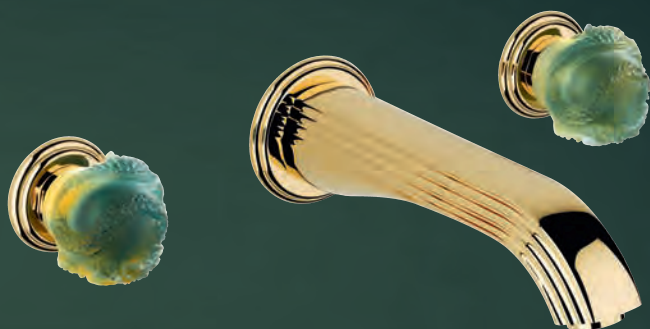

**Ref. U5H.41SG**

Mélangeur de bain 3 trous mural  
Wall mounted 3-hole bath mixer  
3-Loch-Wannenbatterie zur Wandmontage



**Ref. U5H.151**

Mélangeur de lavabo 3 trous  
3-hole basin mixer  
3-Loch-Waschtischbatterie



**Ref. U5H.40G**

Mélangeur de lavabo 3 trous mural  
Wall mounted 3-hole basin mixer  
3-Loch-Waschtischbatterie zur Wandmontage



**Ref. U5H.1132SG**

Mélangeur de bain avec douche alimentée par mitigeur  
Bath mixer + handshower set with single lever mixer  
Wannenbatterie zur Standmontage mit 1-Loch-Einhandmischer mit Brausegarnitur



**Ref. U5B.5500B**

Garniture pour mitigeur thermostatique avec inverseur 2 sorties  
Trim for THG Thermostat with 2-way diverter  
3-Loch-Waschtischbatterie



**Ref. U5B.1132SG**

Mélangeur de bain avec douchette alimentée par mitigeur  
Bath mixer + handshower set with single lever mixer  
Wannenbatterie zur Standmontage mit 1-Loch-Einhandmischer mit Brausegarnitur



**Ref. U5B.504N**  
Anneau porte-serviette  
Single towel ring  
Handtuchring



**Ref. U5B.151**

Mélangeur de lavabo 3 trous  
Rim mounted 3-hole basin mixer  
3-Loch-Waschtischbatterie

# Paradise

design   
CREATIONS  
Jean-Claude GILIPPON  
PARIS



**Ref. U5C.151**

Mélangeur de lavabo 3 trous  
Rim mounted 3-hole basin mixer  
3-Loch-Waschtischbatterie

84 *Daum*



**Ref. U5C.84L + 286P**

Bras de douche et pomme Ø 200 mm anti-calcaire  
 Wall mounted shower arm and anti-scale shower head Ø 200 mm / 8"  
 Brausearm für Kopfbrause und Stachelbrausekopf Ø 200 mm mit Antikalksystem



**Ref. U5C.546**

Porte-savon mural  
 Wall mounted soap dish  
 Seifenschale zur Wandmontage



**Ref. U5C.5400B**

Garniture pour mitigeur thermostatique  
 avec 2 robinets d'arrêt  
 Trim for THG thermostat with 2 valves  
 Thermostat-Garnitur mit 2 Absperrungen



**Ref. U5C.52**

Ensemble de douche  
 Shower set  
 Duschkombination



**Ref. U5C.517**

Porte-peignoir  
 Single robe hook  
 Bademantelhalter



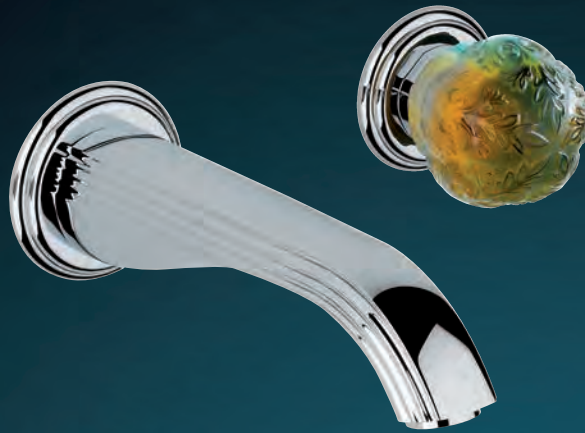

**Ref. U5A.40G**

Mélangeur de lavabo 3 trous mural  
Wall mounted 3-hole basin mixer  
3-Loch-Waschtischbatterie zur Wandmontage



**Ref. U5A.536**

Porte-verre mural  
Wall mounted tumbler  
Wandglashalter mit Glas

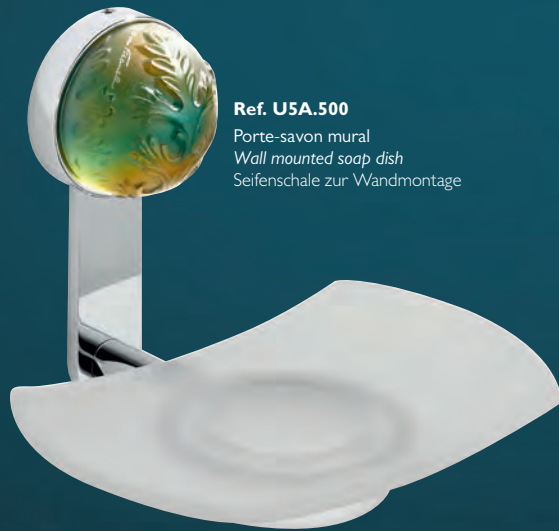

**Ref. U5A.500**

Porte-savon mural  
Wall mounted soap dish  
Seifenschale zur Wandmontage



**Ref. U5A.5840/8**

Ensemble hygiénique  
Hygienic set  
Toilettenspülgarnitur



**Ref. U5A.151**

Mélangeur de lavabo 3 trous mural  
Wall mounted 3-hole basin mixer  
3-Loch-Waschtischbatterie zur Wandmontage

# Vegetal

design   
CREATIONS  
Jean-Louis JEANNERET  
PARIS



**Ref. U5F.5400B**

Garniture pour mitigeur thermostatique  
avec 2 robinets d'arrêt  
*Trim for THG thermostat with 2 valves*  
Thermostat-Garnitur mit 2 Absperrungen

88 *Daum*



**Ref. U5F.151**

Mélangeur de lavabo 3 trous  
Rim mounted 3-hole basin mixer  
3-Loch-Waschtischbatterie



**Ref. U5F.84L + 281EP**

Bras de douche et pomme Ø 200 mm anti-calcaire  
Wall mounted shower arm and anti-scale shower head Ø 200 mm / 8"  
Brausearm für Kopfbrause und Stachelbrausekopf Ø 200 mm mit Antikalksystem



**Ref. U5F.4720C**

Ensemble pot à balai mural  
Wall mounted WC brush set  
WC-Bürstentopf-garnitur



**Ref. U5F.52**

Ensemble de douche  
Shower set  
Duschkombination



**Ref. USE.41SG**  
 Mélangeur de bain 3 trous mural  
 Wall mounted 3-hole bath mixer  
 3-Loch-Wannenbatterie zur Wandmontage



**Ref. USE.151**  
 Mélangeur de lavabo 3 trous  
 Rim mounted 3-hole basin mixer  
 3-Loch-Waschtischbatterie



**Ref. USE.5500B**  
 Garniture pour mitigeur thermostatique avec  
 inverseur 2 sorties  
 Trim for THG Thermostat with 2-way diverter  
 3-Loch-Waschtischbatterie

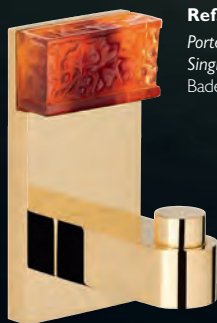

**Ref. USE.517**  
 Porte-peignoir  
 Single robe hook  
 Bademantelhaken

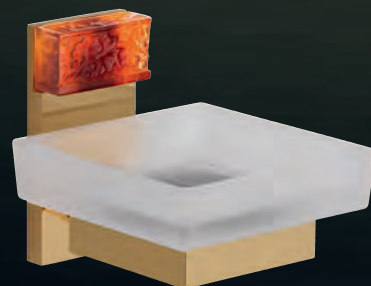

**Ref. USE.500**  
 Porte-savon mural  
 Wall mounted soap dish  
 Seifenschale zur Wandmontage

# Ginkgo

design   
CREATIONS  
Journé - Classe 18/12/2002  
11682



**Ref. USE.151**

Mélangeur de lavabo 3 trous  
Rim mounted 3-hole basin mixer  
3-Loch-Waschtischbatterie

**Ref. USE.504N**

Anneau porte-serviette  
Single towel ring  
Handtuchring



# BERNARDAUD



Marquise . 94  
Ithaque . 102  
Capucine . 110





**Ref. A7G.151**  
Mélangeur de lavabo 3 trous  
Rim mounted 3-hole basin mixer  
3-Loch-Waschtischbatterie



**Ref. A7G.504N**  
Anneau-porte serviette  
Single towel ring  
Handtuchring

# Marquise platine

design  
  
CREATIONS  
Jean-Claude BERNARDAUD  
PARIS



**Ref. A7G.2155**

Mélangeur de lavabo monotrou avec vidage  
*Rim mounted one hole basin mixer*  
I-Loch-Zweigriff-Waschtischbatterie



**Ref. A7G.25SG + 6532/60A**

Mélangeur de bain avec douchette alimentée par mitigeur  
*Bath mixer + handshower set with single lever mixer*  
Wannenbatterie zur Standmontage mit I-Loch-Einhandmischer mit Brausegarnitur



**Ref. A7G.514**

Porte-serviette  
*Single towel rail*  
Handtuchstange

BERNARDAUD 95

# Marquise platine

design  
  
 CREATIFS  
 Jean-Claude FELDENZ  
 PARIS

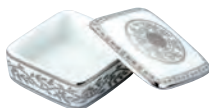

**Ref. A7G.4617**  
 Boîte à pilules 6 x 6 cm  
 Square pills box 6x6 cm  
 Box 6 x 6 cm



**Ref. A7G.4607**  
 Porte-savon 15 x 10 cm  
 Soap dish 15x10 cm  
 Seifenschale 15 x 10 cm



**Ref. A7G.4615**  
 Coupelle Ø 13 cm  
 Dish Ø 13 cm  
 Schale Ø 13 cm



**Ref. A7G.4614**  
 Plateau 22 x 20 cm  
 Tray 22x20 cm  
 Flache Schale 22x20 cm

**Ref. A7G.4613**  
 Plateau 17 x 15 cm  
 Tray 17x15 cm  
 Flache Schale 17x15 cm

**Ref. A7G.4612**  
 Plateau 12 x 11 cm  
 Tray 12x11 cm  
 Flache Schale 12x11 cm



**Ref. A7G.4608**  
 Timbale - Ø 8 - H. 9 cm  
 Cup - Ø 8 - H. 9 cm  
 Becher - Ø 8 - H. 9 cm



**Ref. A7G.4618**  
 Bougeoir suédois Ø 6 - H. 5 cm  
 Sweden candle-holder - Ø 6 - H. 5 cm  
 Schwedischer Kerzenleuchter - Ø 6 - H. 5 cm



**Ref. A7G.4621\***  
 Boîte Ø 13 - H. 17 cm  
 Box - Ø 13 - H. 17 cm  
 Dose - Ø 13 - H. 17 cm



**Ref. A7G.4619\***  
 Boîte Ø 9 - H. 12 cm  
 Box - Ø 9 - H. 12 cm  
 Dose - Ø 9 - H. 12 cm



**Ref. A7G.4623\***  
 Boîte Ø 18 - H. 10 cm  
 Box - Ø 18 - H. 10 cm  
 Dose - Ø 18 - H. 10 cm



**Ref. A7G.4609**  
 Vase Ø 8 - H. 20 cm  
 Vase - Ø 8 - H. 20 cm  
 Vase - Ø 8 - H. 20 cm



**Ref. A7G.4611**  
 Pot Ø 13 - H. 20 cm  
 Jar - Ø 13 - H. 20 cm  
 Dose - Ø 13 - H. 20 cm



BERNARDAUD 97



**Ref. A7F.3202**  
 Mélangeur de bidet monotrou à rotule  
 One hole bidet mixer swivel jet  
 1-Loch-Zweigriff-Bidetbatterie



**Ref. A7F.2620**  
 Porte-savon et porte-éponge mural  
 Combined soap and sponge dish  
 Wandseifenschale und Schwammkorb



**Ref. A7F.538AC**  
 Porte-papier rouleau  
 Wall mounted WC paper holder  
 WC-Papierhalter



**Ref. A7F.40G**  
 Mélangeur de lavabo 3 trous mural  
 Wall mounted 3-hole basin mixer  
 3-Loch-Waschtischbatterie zur Wandmontage

# Marquise doré

design  
  
CREATIONS  
Jean-Claude BERNARDAUD  
PARIS



**Ref. A7F.151**  
Mélangeur de lavabo 3 trous  
Rim mounted 3-hole basin mixer  
3-Loch-Waschtischbatterie

# Marquise doré

design  
  
 CREATIONS  
 Jean-Claude BERNARDAUD  
 PARIS



**Ref. A7F.4608**  
 Timbale - Ø 8 - H. 9 cm  
 Cup - Ø 8 - H. 9 cm  
 Becher - Ø 8 - H. 9 cm



**Ref. A7F.4618**  
 Bougeoir suédois Ø 6 - H. 5 cm  
 Sweden candle-holder - Ø 6 - H. 5 cm  
 Schwedischer Kerzenleuchter - Ø 6 - H. 5 cm



**Ref. A7F.4617**  
 Boîte à pilules 6 x 6 cm  
 Square pills box 6x6 cm  
 Box 6 x 6 cm



**Ref. A7F.4615**  
 Coupelle Ø 13 cm  
 Dish Ø 13 cm  
 Schale Ø 13 cm



**Ref. A7F.4607**  
 Porte-savon 15 x 10 cm  
 Soap dish 15x10 cm  
 Seifenschale 15 x 10 cm



**Ref. A7F.4621\***  
 Boîte Ø 13 - H. 17 cm  
 Box - Ø 13 - H. 17 cm  
 Dose - Ø 13 - H. 17 cm



**Ref. A7F.4619\***  
 Boîte Ø 9 - H. 12 cm  
 Box - Ø 9 - H. 12 cm  
 Dose - Ø 9 - H. 12 cm



**Ref. A7F.4623\***  
 Boîte Ø 18 - H. 10 cm  
 Box - Ø 18 - H. 10 cm  
 Dose - Ø 18 - H. 10 cm



**Ref. A7F.4614**  
 Plateau 22 x 20 cm  
 Tray 22x20 cm  
 Flache Schale 22x20 cm

**Ref. A7F.4613**  
 Plateau 17 x 15 cm  
 Tray 17x15 cm  
 Flache Schale 17x15 cm

**Ref. A7F.4612**  
 Plateau 12 x 11 cm  
 Tray 12x11 cm  
 Flache Schale 12x11 cm



**Ref. A7F.4609**  
 Vase Ø 8 - H. 20 cm  
 Vase - Ø8 - H. 20 cm  
 Vase - Ø8 - H. 20 cm



**Ref. A7F.4611**  
 Pot Ø 13 - H. 20 cm  
 Jar - Ø13 - H. 20 cm  
 Dose - Ø13 - H.20 cm







**Ref. A7G.25SG + 6532/60A**

Mélangeur de bain avec douchette alimentée par mitigeur  
*Bath mixer + handshower set with single lever mixer*  
Wannenbatterie zur Standmontage mit 1-Loch-Einhandmischer  
mit Brausegarnitur



**Ref. A7B.3202**

Mélangeur de bidet monotrou à rotule  
*Rim mounted 1-hole bidet mixer*  
1-Loch-Bidetbatterie



**Ref. A7B.510**

Porte-peignoir à barrette  
*Robe hook with cross piece*  
Bademantelhaken



**Ref. A7B.546GM**

Coupe murale  
*Wall mounted soap dish*  
Wandseifenschale

# Ithaque *platine*

design  
  
CREATIONS  
Jean-Claude BERNARDAUD  
PARIS



**Ref. A7B.151**  
Mélangeur de lavabo 3 trous  
*Rim mounted 3-hole basin mixer*  
3-Loch-Waschtischbatterie



**Ref. A7B.4617**  
Boîte à pilules 6 x 6 cm  
Square pills box 6x6 cm  
Box 6 x 6 cm



**Ref. A7B.4616**  
Boîte à pilules Ø 6 cm  
Round pills box Ø6 cm  
Box Ø 6 cm

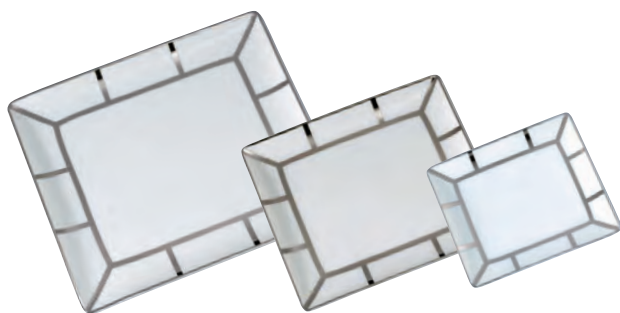

**Ref. A7B.4614**  
Plateau 22 x 20 cm  
Tray 22x20 cm  
Flache Schale 22x20 cm

**Ref. A7B.4613**  
Plateau 17 x 15 cm  
Tray 17x15 cm  
Flache Schale 17x15 cm

**Ref. A7B.4612**  
Plateau 12 x 11 cm  
Tray 12x11 cm  
Flache Schale 12x11 cm



**Ref. A7B.4609**  
Vase Ø 8 - H. 20 cm  
Vase - Ø8 - H. 20 cm  
Vase - Ø8 - H. 20 cm



**Ref. A7B.4611**  
Pot Ø 13 - H. 20 cm  
Jar - Ø13 - H. 20 cm  
Dose - Ø13 - H. 20 cm

# Ithaque platine

design  
  
 CREATIONS  
 Jean-Claude BERTHIAUX  
 PARIS



**Ref. A7B.4608**  
 Timbale - Ø 8 - H. 9 cm  
 Cup - Ø 8 - H. 9 cm  
 Becher - Ø 8 - H. 9 cm



**Ref. A7B.4618**  
 Bougeoir suédois Ø 6 - H. 5 cm  
 Sweden candle-holder - Ø 6 - H. 5 cm  
 Schwedischer Kerzenleuchter - Ø 6 - H. 5 cm



**Ref. A7B.4607**  
 Porte-savon 15 x 10 cm  
 Soap dish 15 x 10 cm  
 Seifenschale 15 x 10 cm



**Ref. A7B.4615**  
 Coupelle Ø 13 cm  
 Dish Ø 13 cm  
 Schale Ø 13 cm



**Ref. A7B.4621\***  
 Boîte Ø 13 - H. 17 cm  
 Box - Ø 13 - H. 17 cm  
 Dose - Ø 13 - H. 17 cm



**Ref. A7B.4619\***  
 Boîte Ø 9 - H. 12 cm  
 Box - Ø 9 - H. 12 cm  
 Dose - Ø 9 - H. 12 cm



**Ref. A7B.4623\***  
 Boîte Ø 18 - H. 10 cm  
 Box - Ø 18 - H. 10 cm  
 Dose - Ø 18 - H. 10 cm



\* Boîte en bois peinte en laque de Chine avec couvercle en porcelaine  
 Wooden box coated with Chinese lacquer with a porcelain lid  
 Holzbox mit Chinalack und Porzellan-Deckel



**Ref. A7A.41SG**

Mélangeur de bain mural 3 trous  
Wall mounted 3-hole bath mixer  
3-Loch-Wannenfüllbatterie zur Wandmontage



**Ref. A7A.4720C**

Ensemble pot à balai mural  
Wall mounted WC brush set  
WC-Bürstentopf-garnitur



**Ref. A7A.151**

Mélangeur de lavabo 3 trous  
Rim mounted 3-hole basin mixer  
3-Loch-Waschtischbatterie



**Ref. A7A.538AC**

Porte-papier rouleau  
Wall mounted WC paper holder  
WC-Papierhalter



**Ref. A7A.2155**

Mélangeur de lavabo monotrou  
Rim mounted one hole basin mixer  
1-Loch-Zweigriff-Waschtischbatterie

# Ithaque doré

design  
  
CREATIONS  
Jean-Christophe BERNARDAUD  
PARIS



BERNARDAUD 107

# Ithaque doré

design  
  
 CREATIONS  
 Jean-Claude BERNARDAUD  
 PARIS



**Ref. A7A.4614**  
 Plateau 22 x 20 cm  
 Tray 22x20 cm  
 Fläche Schale 22x20 cm

**Ref. A7A.4613**  
 Plateau 17 x 15 cm  
 Tray 17x15 cm  
 Fläche Schale 17x15 cm

**Ref. A7A.4612**  
 Plateau 12 x 11 cm  
 Tray 12x11 cm  
 Fläche Schale 12x11 cm



**Ref. A7A.4621\***  
 Boîte Ø 13 - H. 17 cm  
 Box - Ø13 - H. 17 cm  
 Dose - Ø13 - H. 17 cm

**Ref. A7A.4619\***  
 Boîte Ø 9 - H. 12 cm  
 Box - Ø9 - H. 12 cm  
 Dose - Ø9 - H. 12 cm

**Ref. A7A.4623\***  
 Boîte Ø 18 - H. 10 cm  
 Box - Ø18 - H. 10 cm  
 Dose - Ø18 - H. 10 cm



**Ref. A7A.4609**  
 Vase Ø 8 - H. 20 cm  
 Vase - Ø8 - H. 20 cm  
 Vase - Ø8 - H. 20 cm

**Ref. A7A.4611**  
 Pot Ø 13 - H. 20 cm  
 Jar - Ø13 - H. 20 cm  
 Dose - Ø13 - H. 20 cm

\* Boîte en bois peinte en laque de Chine avec couvercle en porcelaine  
 Wooden box coated with Chinese lacquer with a porcelain lid  
 Holzbox mit Chinalack und Porzellan-Deckel



**Ref. A7A.4608**  
Timbale - Ø 8 - H. 9 cm  
Cup - Ø 8 - H. 9 cm  
Becher - Ø 8 - H. 9 cm



**Ref. A7A.4618**  
Bougeoir suédois Ø 6 - H. 5 cm  
Sweden candle-holder - Ø 6 - H. 5 cm  
Schwedischer Kerzenleuchter - Ø 6 - H. 5 cm



**Ref. A7A.4617**  
Boîte à pilules 6 x 6 cm  
Square pills box 6x6 cm  
Box 6 x 6 cm



**Ref. A7A.4616**  
Boîte à pilules Ø 6 cm  
Round pills box Ø 6 cm  
Box Ø 6 cm



**Ref. A7A.4607**  
Porte-savon 15 x 10 cm  
Soap dish 15x10 cm  
Seifenschale 15 x 10 cm



**Ref. A7A.4615**  
Coupelle Ø 13 cm  
Dish Ø 13 cm  
Schale Ø 13 cm







**Ref. A7E.112BSG**

Mélangeur bain-douche 4 trous  
*Rim mounted 4-hole bath shower mixer*  
 4-Loch-Wannenfüll- und Brausebatterie



**Ref. A7E.3202**

Mélangeur de bidet monotrou à rotule  
*One hole bidet mixer swivel jet*  
 1-Loch-Zweigriff-Bidetbatterie



**Ref. A7E.13B**

Mélangeur bain-douche mural  
*Wall mounted 2-hole bath-shower mixer*  
 Wannenwandbatterie



**Ref. A7E.546GM**

Coupe murale  
*Wall mounted soap dish*  
 Wandseifenschale



**Ref. A7E.504N**

Anneau porte-serviette  
*Single towel ring*  
 Handtuchring

# Capucine vert

design  
  
CREATIONS  
Jean-Claude BERNARDAUD  
PARIS



**Ref. A7E.151**  
Mélangeur de lavabo 3 trous  
Rim mounted 3-hole basin mixer  
3-Loch-Waschtischbatterie



**Ref. A7E.4617**  
Boîte à pilules 6 x 6 cm  
Square pills box 6x6 cm  
Box 6 x 6 cm



**Ref. A7E.4616**  
Boîte à pilules Ø 6 cm  
Round pills box Ø6 cm  
Box Ø 6 cm



**Ref. A7E.4610**  
Pot à pinceaux Ø 9 - H. 9 cm  
Make-up paintbrush pot - Ø9 - H. 9 cm  
Schminkpinsel-Box - Ø9 - H.9 cm



**Ref. A7E.4608**  
Timbale - Ø 8 - H. 9 cm  
Cup - Ø8 - H. 9 cm  
Becher - Ø8 - H.9 cm



**Ref. A7E.4609**  
Vase Ø 8 - H. 20 cm  
Vase - Ø8 - H. 20 cm  
Vase - Ø8 - H. 20 cm



**Ref. A7E.4611**  
Pot Ø 13 - H. 20 cm  
Jar - Ø13 - H. 20 cm  
Dose - Ø13 - H. 20 cm

# Capucine vert

design  
CREATIONS  
Jean-Claude BALLEZ  
PARIS



**Ref. A7E.4618**  
Bougeoir suédois Ø 6 - H. 5 cm  
Swedish candle-holder - Ø6 - H. 5 cm  
Schwedischer Kerzenleuchter - Ø 6 - H. 5 cm



**Ref. A7E.4615**  
Coupelle Ø 13 cm  
Dish Ø13 cm  
Schale Ø 13 cm



**Ref. A7E.4607**  
Porte-savon 15 x 10 cm  
Soap dish 15x10 cm  
Seifenschale 15 x 10 cm



**Ref. A7E.4614**  
Plateau 22 x 20 cm  
Tray 22x20 cm  
Flache Schale 22x20 cm

**Ref. A7E.4613**  
Plateau 17 x 15 cm  
Tray 17x15 cm  
Flache Schale 17x15 cm

**Ref. A7E.4612**  
Plateau 12 x 11 cm  
Tray 12x11 cm  
Flache Schale 12x11 cm



**Ref. A7E.4621\***  
Boîte Ø 13 - H. 17 cm  
Box - Ø13 - H. 17 cm  
Dose - Ø 13 - H. 17 cm



**Ref. A7E.4619\***  
Boîte Ø 9 - H. 12 cm  
Box - Ø9 - H. 12 cm  
Dose - Ø 9 - H. 12 cm



**Ref. A7E.4623\***  
Boîte Ø 18 - H. 10 cm  
Box - Ø18 - H. 10 cm  
Dose - Ø 18 - H. 10 cm



\* Boîte en bois peinte en laque de Chine avec couvercle en porcelaine  
Wooden box coated with Chinese lacquer with a porcelain lid  
Holzbox mit Chinalack und Porzellan-Deckel



**Ref. A7D.151**

Mélangeur de lavabo 3 trous  
Rim mounted 3-hole basin mixer  
3-Loch-Waschtischbatterie

# Capucine mauve

design  
  
CREATIONS  
Jean-Claude BERNARDAUD  
PARIS



**Ref. A7D.41SG**

Mélangeur de bain mural 3 trous  
Wall mounted 3-hole bath mixer  
3-Loch-Wannenfüllbatterie zur Wandmontage



**Ref. A7D.112BSG**

Mélangeur bain-douche 4 trous  
Rim mounted 4-hole bath shower mixer  
4-Loch-Wannenfüll- und Brausebatterie



**Ref. A7D.546**

Coupe murale  
Wall mounted soap dish  
Wandseifenschale



**Ref. A7D.514/50**

Porte-serviette  
Single towel rail  
Handtuchstange

# Capucine mauve

design  
**CS**  
CREATIONS  
Jean-Claude DELZENNE  
PARIS



**Ref. A7D.4617**  
Boîte à pilules 6 x 6 cm  
Square pills box 6x6 cm  
Box 6 x 6 cm



**Ref. A7D.4616**  
Boîte à pilules Ø 6 cm  
Round pills box Ø6 cm  
Box Ø 6 cm



**Ref. A7D.4618**  
Bougeoir suédois Ø 6 - H. 5 cm  
Sweden candle-holder - Ø6 - H. 5 cm  
Schwedischer Kerzenleuchter - Ø6 - H. 5 cm



**Ref. A7D.4608**  
Timbale - Ø 8 - H. 9 cm  
Cup - Ø8 - H. 9 cm  
Becher - Ø8 - H. 9 cm



**Ref. A7D.4610**  
Pot à pinceaux Ø 9 - H. 9 cm  
Make-up paintbrush pot - Ø9 - H. 9 cm  
Schminkpinsel-Box - Ø9 - H. 9 cm



**Ref. A7D.4614**  
Plateau 22 x 20 cm  
Tray 22x20 cm  
Flache Schale 22x20 cm

**Ref. A7D.4613**  
Plateau 17 x 15 cm  
Tray 17x15 cm  
Flache Schale 17x15 cm

**Ref. A7D.4612**  
Plateau 12 x 11 cm  
Tray 12x11 cm  
Flache Schale 12x11 cm



**Ref. A7D.4607**  
Porte-savon 15 x 10 cm  
Soap dish 15x10 cm  
Seifenschale 15 x 10 cm



**Ref. A7D.4615**  
Coupelle Ø 13 cm  
Dish Ø13 cm  
Schale Ø 13 cm



**Ref. A7D.4621\***  
Boîte Ø 13 - H. 17 cm  
Box - Ø13 - H. 17 cm  
Dose - Ø13 - H. 17 cm



**Ref. A7D.4619\***  
Boîte Ø 9 - H. 12 cm  
Box - Ø9 - H. 12 cm  
Dose - Ø9 - H. 12 cm



**Ref. A7D.4623\***  
Boîte Ø 18 - H. 10 cm  
Box - Ø18 - H. 10 cm  
Dose - Ø 18 - H. 10 cm



**Ref. A7D.4609**  
Vase Ø 8 - H. 20 cm  
Vase - Ø8 - H. 20 cm  
Vase - Ø8 - H. 20 cm



**Ref. A7D.4611**  
Pot Ø 13 - H. 20 cm  
Jar - Ø13 - H. 20 cm  
Dose - Ø 13 - H. 20 cm







# PRESTIGE



Poèmes .	120
Bagatelle .	124
Vogue .	130
Jaipur .	134
Trocadéro .	138
Amboise .	142
Cheverny .	144
Sully .	148
Duomo .	150



**Ref. A7L.504N**  
Anneau porte-serviette  
Single towel ring  
Handtuchring

*Beautiful ...*  
*Glamour ...*

**Ref. A7L.536B**  
Porte-verre mural  
Wall mounted tumbler  
Wandglashalter



**Ref. A7L.500B**  
Porte-savon mural  
Wall mounted soap dish  
Seifenschale zur Wandmontage



**Ref. A7L.41SG**  
Mélangeur de bain 3 trous mural  
Wall mounted 3-hole bath mixer  
3-Loch-Wannenfüllbatterie zur Wandmontage





Design Chantal Thomass

PRESTIGE 121



**Ref. A7L.4617**  
Boîte à pilules 6 x 6 cm  
Square pills box 6x6 cm  
Box 6 x 6 cm



**Ref. A7L.4616**  
Boîte à pilules Ø 6 cm  
Round pills box Ø6 cm  
Box Ø 6 cm

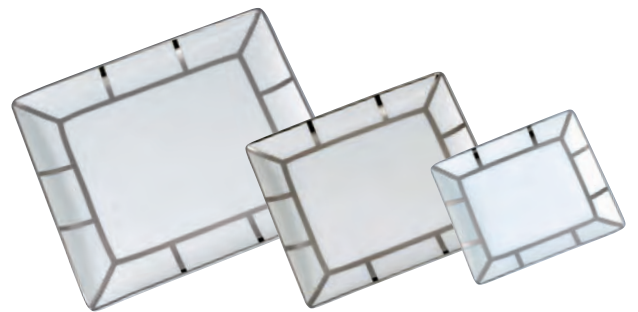

**Ref. A7L.4614**  
Plateau 22 x 20 cm  
Tray 22x20 cm  
Flache Schale 22x20 cm

**Ref. A7L.4613**  
Plateau 17 x 15 cm  
Tray 17x15 cm  
Flache Schale 17x15 cm

**Ref. A7L.4612**  
Plateau 12 x 11 cm  
Tray 12x11 cm  
Flache Schale 12x11 cm



**Ref. A7L.4609**  
Vase Ø 8 - H. 20 cm  
Vase - Ø8 - H. 20 cm  
Vase - Ø8 - H. 20 cm



**Ref. A7L.4611**  
Pot Ø 13 - H. 20 cm  
Jar - Ø13 - H. 20 cm  
Dose - Ø13 - H. 20 cm



**Ref. A7L.4608**  
Timbale - Ø 8 - H. 9 cm  
Cup - Ø 8 - H. 9 cm  
Becher - Ø 8 - H. 9 cm



**Ref. A7L.4618**  
Bougeoir suédois Ø 6 - H. 5 cm  
Sweden candle-holder - Ø 6 - H. 5 cm  
Schwedischer Kerzenleuchter - Ø 6 - H. 5 cm



**Ref. A7L.4607**  
Porte-savon 15 x 10 cm  
Soap dish 15x10 cm  
Seifenschale 15 x 10 cm



**Ref. A7L.4615**  
Coupelle Ø 13 cm  
Dish Ø 13 cm  
Schale Ø 13 cm



**Ref. A7L.4621\***  
Boîte Ø 13 - H. 17 cm  
Box - Ø 13 - H. 17 cm  
Dose - Ø 13 - H. 17 cm



**Ref. A7L.4619\***  
Boîte Ø 9 - H. 12 cm  
Box - Ø 9 - H. 12 cm  
Dose - Ø 9 - H. 12 cm



**Ref. A7L.4623\***  
Boîte Ø 18 - H. 10 cm  
Box - Ø 18 - H. 10 cm  
Dose - Ø 18 - H. 10 cm



\* Boîte en bois peinte en laque de Chine avec couvercle en porcelaine  
Wooden box coated with Chinese lacquer with a porcelain lid  
Holzbox mit Chinalack und Porzellan-Deckel





Design Olivier GAGNÈRE

PRESTIGE 125



# Bagatelle métal

by  
  
CREATIONS  
Jean Claude FELIPPE  
PARIS



**Ref. U3A.151**  
Mélangeur de lavabo 3 trous  
Rim mounted 3-hole basin mixer  
3-Loch-Waschtischbatterie



**Ref. U3A.41G**  
Mélangeur de bain 3 trous mural  
Wall mounted 3-hole bath mixer  
3-Loch-Wannenfüllbatterie  
zur Wandmontage



**Ref. U3B.151**  
Mélangeur de lavabo 3 trous  
Rim mounted 3-hole basin mixer  
3-Loch-Waschtischbatterie



**Ref. U3A.6506**

Mitigeur de lavabo à cartouche progressive  
*Single lever basin mixer with progressive cartridge*  
Waschtisch-Einhebelmischer mit progressiver Kartusche



**Ref. U3A.49/3VM**

Inverseur 4 voies mural  
avec cartouche céramique  
*Wall mounted diverter with ceramic cartridge*  
Umstellventil zur Unterputzmontage  
mit Keramikelement

# Bagatelle

## *pierre noire*

by  
  
 CREATIONS  
 Jean-Charles DELLEPPE  
 PARIS



**Ref. U3E.112BSG**

Mélangeur bain-douche 4 trous sur gorge  
*Rim mounted 4-hole bath shower mixer*  
 4-Loch-Wannenfüll- und Brausebatterie zur Standmontage



**Ref. U3E.151**

Mélangeur de lavabo 3 trous  
*Rim mounted 3-hole basin mixer*  
 3-Loch-Waschtischbatterie



**Ref. U3E.500BD**

Porte-savon mural  
*Wall mounted soap dish*  
 Seifenschale zur Wandmontage



**Ref. U3F.40G**

Mélangeur de lavabo 3 trous mural  
*Wall mounted 3-hole basin mixer*  
 3-Loch-Waschtischbatterie zur Wandmontage



**Ref. U3E.5100B**

Garniture pour mitigeur thermostatique  
*Trim for thermostat*  
 Thermostat-Garnitur



**Ref. U3F.151**

Mélangeur de lavabo 3 trous  
*Rim mounted 3-hole basin mixer*  
 3-Loch-Waschtischbatterie

# Bagatelle

*cristal*

by   
CREATIONS  
Jean-Claude DELBESNE  
PARIS



**Ref. U3C.151**

Mélangeur de lavabo 3 trous  
Rim mounted 3-hole basin mixer  
3-Loch-Waschtischbatterie

PRESTIGE

129



**Ref. A8B.41SG**

Mélangeur de lavabo 3 trous mural - Améthyste  
Wall mounted basin set - Amethyst  
3-Loch-Waschtischbatterie zur Wandmontage - Amethyst



**Ref. A8B.538AC**

Porte-papier - Améthyste  
Wall mounted WC paper holder - Amethyst  
WC-Papierhalter - Amethyst

**Ref. A8B.151**

Mélangeur de lavabo 3 trous - Améthyste  
Rim mounted 3-hole basin mixer - Amethyst  
3-Loch-Waschtischbatterie - Amethyst





**Ref. A8N**  
Jaspe rouge  
Red jasper  
Roter Jaspis



**Ref. A8B**  
Améthyste  
Amethyst  
Amethyst

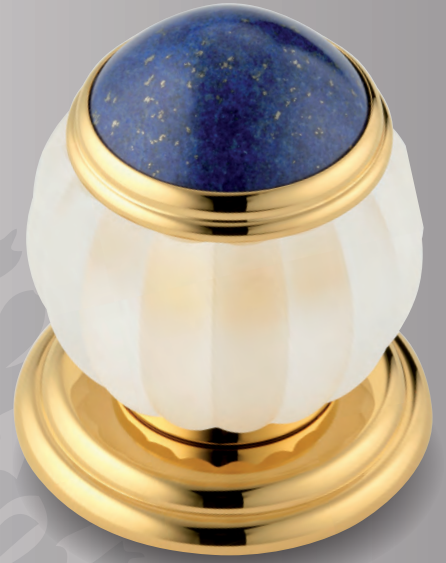

**Ref. A8S**  
Lapis lazuli  
Lapis lazuli  
Lapis Lazuli



**Ref. A8M**  
Malachite  
Malachite  
Malachit



**Ref. A8R**  
Œil de tigre  
Tiger eye  
Tigerauge



**Ref. A8P**  
Onyx noir  
Black onyx  
Schwarzer Onyx



**Ref. A8B.504N**

Anneau porte-serviette - Améthyste  
Single towel ring - Amethyst  
Handtuchring - Amethyst



# Jaipur métal

design  
  
CRÉATIONS  
Avec l'ambition de l'élégance  
PARIS



**Ref. A9F.504N**  
Anneau porte-serviette  
Single towel ring  
Handtuchring



**Ref. A9F.538AC**  
Porte-papier  
Wall mounted WC paper holder  
WC-Papierhalter



**Ref. A9F.546GM**  
Coupe murale  
Wall mounted soap dish  
Wandseifenschale





**Ref. A9F.151**

Mélangeur de lavabo 3 trous / Rim mounted 3-hole basin mixer / 3-Loch-Waschtischbatterie

PRESTIGE

135

# Jaipur onyx noir

design   
CREATIONS  
Jean-Claude DELFINO  
PARIS



**Ref. A9C.151**

Mélangeur de lavabo 3 trous - Onyx noir  
Rim mounted 3-hole basin mixer - Black onyx  
3-Loch-Waschtischbatterie - Schwarzer Onyx

# Jaipur cristal satiné

design  
  
CREATIONS  
JACQUES-CHARLES HILLESIMT  
PARIS



**Ref. A9B.151**

Mélangeur de lavabo 3 trous - Cristal satiné  
Rim mounted 3-hole basin mixer - Satin crystal  
3-Loch-Waschtischbatterie - Satinierter Kristall



**Ref. A9B.517**

Porte-peignoir - Cristal satiné  
Robe hook ball - Satin crystal  
Bademantelhaken - Satinierter Kristall





© MGM Marbles & Stones  
MGM  
Marbles and Stones

138 PRESTIGE

# Trocadéro

design  
  
CREATIONS  
Jean-Claude BOISSONNE  
PARIS



**Ref. U7E.40G**

Mélangeur de lavabo 3 trous mural - Œil de tigre  
Wall mounted basin set - Tiger eye  
3-Loch-Waschtischbatterie zur Wandmontage - Tigerauge



**Ref. U7E.538AC**

Porte-papier - Œil de tigre  
Wall mounted WC paper holder - Tiger eye  
WC-Papierhalter - Tigerauge



**Ref. U7E.546GM**

Coupe murale - Œil de tigre  
Wall mounted soap dish - Tiger eye  
Wandseifenschale - Tigerauge



**Ref. U7E.504N**

Anneau porte-serviette - Œil de tigre  
Single towel ring - Tiger eye  
Handtuchring - Tigerauge

**Ref. U7E.151**

Mélangeur de lavabo 3 trous - Œil de tigre  
Rim mounted 3-hole basin mixer - Tiger eye  
3-Loch-Waschtischbatterie - Tigerauge

PRESTIGE 139

# Trocadéro

design   
CREATIONS  
Jewelry - Clocks - Watches  
PARIS



**Ref. U7C**  
Jaspe rouge  
Red jasper  
Roter Jaspis



**Ref. U7A**  
Malachite  
Malachite  
Malachit



**Ref. U7D**  
Onyx noir  
Black onyx  
Schwarzer Onyx



**Ref. U7B**  
Lapis lazuli  
Lapis lazuli  
Lapis Lazuli







XIV.LI  
MGM  
Marbles and Stones  
© MGM Marbles & Stones

142 PRESTIGE

Ref. AIL.151  
Mélangeur de lavabo 3 trous - Jaspe rouge  
Rim mounted 3-hole basin mixer - Red Jasper  
3-Loch-Waschtischbatterie - Roter Jaspis

# Amboise

design  
  
CREATIONS  
Jean-Claude DESSINE  
PARIS

**Ref. A1L**

Jaspe rouge  
Red jasper  
Roter Jaspis



**Ref. A1J**

Malachite  
Malachite  
Malachit



**Ref. A1M**

Onyx noir  
Black onyx  
Schwarzer  
Onyx



**Ref. A1K**

Lapis lazuli  
Lapis lazuli  
Lapis Lazuli



**Ref. A1K.2155**

Mélangeur de lavabo monotrou - Lapis lazuli

Rim mounted one hole basin mixer - Lapis lazuli

1-Loch-Zweigriff-Waschtischbatterie - Lapis Lazuli



**Ref. A1K.5100B**

Garniture pour mitigeur thermostatique - Lapis lazuli

Trimings for thermostat - Lapis lazuli

Thermostat-Garnitur - Lapis Lazuli



**Ref. A1K.504N**

Anneau porte-serviette - Lapis lazuli

Single towel ring - Lapis lazuli

Handtuchring - Lapis Lazuli

PRESTIGE

143

**Ref. AIT.4720C**

Ensemble pot à balai mural - Lapis lazuli  
Wall mounted WC brush set - Lapis lazuli  
WC-Bürstentopf-garnitur - Lapis Lazuli



**Ref. AIT.3202**

Mélangeur de bidet monotrou à rotule - Lapis lazuli  
Rim mounted one hole bidet mixer - Lapis lazuli  
1-Loch-Zweigriff-Bidetbatterie - Lapis Lazuli



**Ref. AIT.538AC**

Porte-papier - Lapis lazuli  
Wall mounted WC paper holder - Lapis lazuli  
WC-Papierhalter - Lapis Lazuli





**Ref. UIV.151**

Mélangeur de lavabo 3 trous - Onyx noir  
Rim mounted 3-hole basin mixer - Black onyx  
3-Loch-Waschtischbatterie - Schwarzer Onyx

PRESTIGE | 145

Cheverny



146 PRESTIGE



**Ref. AIU**  
Jaspe rouge / Red jasper / Roter Jaspis



**Ref. AIT**  
Lapis lazuli  
Lapis lazuli  
Lapis Lazuli



**Ref. AIS**  
Malachite  
Malachite  
Malachit



**Ref. UIV**  
Onyx noir  
Black onyx  
Schwarzer Onyx



**Ref. UIS.151**

Mélangeur de lavabo 3 trous - Onyx blanc  
Rim mounted 3-hole basin mixer - White onyx  
3-Loch-Waschtischbatterie - Weißer Onyx

148 PRESTIGE



**Ref. UIS**  
 Onyx blanc  
 White onyx  
 Weißer Onyx



**Ref. UIT**  
 Onyx noir  
 Black onyx  
 Schwarzer Onyx



**Ref. AIV**  
 Malachite  
 Malachite  
 Malachit



**Ref. AIX**  
 Jaspe rouge  
 Red jasper  
 Roter Jaspis



**Ref. AIW**  
 Lapis lazuli  
 Lapis lazuli  
 Lapis Lazuli



**Ref. UIS.2155**  
 Mélangeur de lavabo monotrou - Onyx blanc  
 Rim mounted one hole basin mixer - White onyx  
 1-Loch-Zweigriff-Waschtischbatterie - Weißer Onyx



# Duomo

design   
CREATIONS  
Jean-Louis HEDRIN  
PARIS



**Ref. U4E.504N**  
Anneau porte-serviette  
Single towel ring  
Handtuchring



150 PRESTIGE

**Ref. U4E.151**  
Mélangeur de lavabo 3 trous  
Rim mounted 3-hole basin mixer  
3-Loch-Waschtischbatterie







# Duomo cristal

design  
  
CREATIONS  
Jean-Claude BOZZESE  
PARIS



**Ref. U4F.4720C**  
Ensemble pot à balai mural  
Wall mounted WC brush set  
WC-Bürstentopfgerüst



**Ref. U4F.538AC**  
Porte-papier  
Wall mounted WC paper holder  
WC-Papierhalter



**Ref. U4F.52**  
Ensemble de douche  
Shower set  
Duschkombination



**Ref. U4F.151**  
Mélangeur de lavabo 3 trous  
Rim mounted 3-hole basin mixer  
3-Loch-Waschtischbatterie



# CONTEMPORAINE



Collection O . 156

Nano . 160

Anoa . 164

Le 11 by Alberto Pinto . 170

So . 174

Profil . 178

Marina . 184

Beluga . 188

Pure . 192

# Collection O

by  
**JD**  
CREATIONS  
Jean-Charles DELPESSÉ  
PARIS



**Ref. G4P.536**  
Porte-verre mural  
Wall mounted tumbler  
Wandglashalter mit Glas



**Ref. G4P.500**  
Porte-savon  
Soap dish  
Seifenschale



**Ref. G4P.504N**  
Anneau porte-serviette  
Single towel ring  
Handtuchring

**Ref. G4P.6501B**  
Mitigeur de lavabo  
Single lever basin mixer  
Waschtisch-Einhebelmischer

**Ref. G4P.151**  
Mélangeur de lavabo 3 trous  
3-hole basin mixer  
3-Loch-Waschtischbatterie



Design Studio PUTMAN - *Christofle*  
PARIS

CONTEMPORAINE

157







**Ref. G4P.6508S**  
Mitigeur bain-douche sur colonne  
Free-standing bath shower mixer  
Freistehende Wannenfüll- und Brausearmatur



**Ref. G4P.514**  
Porte-serviette  
Single towel rail  
Handtuchstange



# Collection O

by  
**CS**  
CREATIONS  
Jean Claude DESPINS  
PARIS

**Ref. G4P.112BSG**

Mélangeur bain-douche 4 trous  
4-hole bath shower mixer  
4-Loch-Wannenfüll-und Brausebatterie



**Ref. G4P.5500B + 54 + 82V + 280EP**

Ensemble de douche thermostatique  
avec pomme de douche Ø 300 mm  
Wall mounted shower thermostatic set  
with showerhead Ø 300 mm  
Thermostat Duschbatterie  
mit Brausekopf Ø 300 mm



**Ref. G4P.517**

Porte-peignoir  
Single robe hook  
Bademantelhalter

**Ref. G4P.6529CD**

Ensemble de douche thermostatique  
avec pomme de douche Ø 200 mm  
Wall mounted shower thermostatic set  
with showerhead Ø 200 mm  
Thermostat Duschbatterie  
mit Brausekopf Ø 200 mm

**Ref. G5A.6529CD**

Ensemble de douche thermostatique  
avec pomme de douche Ø 200 mm  
Wall mounted shower thermostatic set  
with showerhead Ø 200 mm  
Thermostat Duschbatterie  
mit Brausekopf Ø 200 mm



**Ref. G5A.152**

Mélangeur de lavabo 3 trous - Bec haut  
3-hole basin mixer - High spout  
3-Loch-Waschtischbatterie - Hohem Auslauf



**Ref. G5A.112BSGBH**

Mélangeur bain-douche 4 trous - Bec haut  
4-hole bath shower mixer - High spout  
4-Loch-Wannenfüll- und Brausebatterie - Hohem Auslauf

# Nano à manettes

design  
  
CERRETTA  
S.p.A.



**Ref. G5B.152**

Mélangeur de lavabo 3 trous - Bec haut  
3-hole basin mixer - High spout  
3-Loch-Waschtischbatterie - Hohem Auslauf



**Ref. G5B.112BSGBB**  
 Mélangeur bain-douche 4 trous  
 4-hole bath shower mixer  
 4-Loch-Wannenfüll- und Brausebatterie

**Ref. G5A.151**  
 Mélangeur de lavabo 3 trous  
 3-hole basin mixer  
 3-Loch-Waschtischbatterie



**Ref. G5B.6501B**  
 Mitigeur de lavabo  
 Single lever basin mixer  
 Waschtisch-Einhebelmischer



**Ref. G5B.6508S**  
 Mitigeur bain-douche sur colonne  
 Free-standing bath shower mixer  
 Freistehende Wannenfüll- und Brausearmatur



**Ref. G5B.521/60**  
 Porte-serviette  
 Single towel rail  
 Handtuchstange



# Anoa

corne claire

design  
  
CREATIVE  
DESIGN



La corne de zébu, espèce non protégée (prélevée conformément aux autorisations) étant une matière naturelle, la teinte et le veinage de celle-ci ne peuvent en aucun cas être garantis et l'intensité des couleurs peut varier d'un élément à l'autre.

*As horns of zebus, non protective species (horns collected in accordance with authorizations) are a natural material, in no case we can guarantee their grain and diversity in colour- the colour intensities of that line may vary.*

Das Zebuhorn, keine geschützte Art (gemäß Genehmigung), ist ein natürliches Material und kann daher Abweichungen im Farbton und in der Schattierung enthalten. Farbton und Maserung unterliegen keiner Garantie.



# Anoa

corne claire

design   
CARRERAS  
ARCHITECTURE



 166 CONTEMPORAINE



**Ref. G5C.504N**  
 Anneau porte-serviette  
 Single towel ring  
 Handtuchring



**Ref. G5C.517**  
 Porte-peignoir  
 Single robe hook  
 Bademantelhalter

**Ref. G5C.152**  
 Mélangeur de lavabo 3 trous - Bec haut - Corne claire  
 3-hole basin mixer - High spout - Clear horn  
 3-Loch-Waschtischbatterie - Hohem Auslauf - Helles Horn

**Ref. G5C.6529CD**  
 Ensemble de douche thermostatique  
 avec pomme de douche Ø 200 mm  
 Wall mounted shower thermostatic set  
 with showerhead Ø 200 mm  
 Thermostat Duschbatterie  
 mit Brausekopf Ø 200 mm



**Ref. G5D.152**

Mélangeur de lavabo 3 trous - Bec haut - Corne noire  
 3-hole basin mixer - High spout - Black horn  
 3-Loch-Waschtischbatterie - Hohem Auslauf - Schwarzes Horn



design   
 CREATIONS  
 Jean-Claude GILLESPIE  
 PARIS

Anoa  
 corne noire

**Ref. G5D.151**

Mélangeur de lavabo 3 trous - Corne noire  
 3-hole basin mixer - High spout - Black horn  
 3-Loch-Waschtischbatterie - Hohem Auslauf - Schwarzes Horn



**Ref. G5D.5500B - 54**

Ensemble de douche - Corne noire  
 Shower set - Black horn  
 Duschkombination - Schwarzes Horn



**Ref. G5D.112BSGGB**

Mélangeur bain-douche 4 trous - Corne noire  
 4-hole bath shower mixer - Black horn  
 4-Loch-Wannenfüll-und Brausebatterie - Schwarzes Horn



**Ref. G5D.6501H**

Mitigeur de lavabo - Modèle haut  
Single lever basin mixer  
Waschtisch-Einhebelmischer



La corne de zébu, espèce non protégée (prélevée conformément aux autorisations) étant une matière naturelle, la teinte et le veinage de celle-ci ne peuvent en aucun cas être garantis et l'intensité des couleurs peut varier d'un élément à l'autre.

*As horns of zebus, non protective species (horns collected in accordance with authorizations) are a natural material, in no case we can guarantee their grain and diversity in colour- the colour intensities of that line may vary.*

Das Zebuhorn, keine geschützte Art (gemäß Genehmigung), ist ein natürliches Material und kann daher Abweichungen im Farbton und in der Schattierung enthalten. Farbton und Maserung unterliegen keiner Garantie.

# Le II by Alberto Pinto

by   
CREATIONS  
Journé - Année 2012/2013  
PARIS



**Ref. U2A.151**

Mélangeur de lavabo 3 trous  
*Rim mounted 3-hole basin mixer*  
3-Loch-Waschtischbatterie



**Ref. U2A.1132/A**

Mélangeur de bain sur gorge et douchette alimentée par mitigeur  
*Rim mounted bath mixer and handshower set with single lever mixer*  
Wannenbatterie und 1-Loch-Einhandmischer mit Brausegarnitur

**Ref. U2A.5500B - 54**

Ensemble de douche thermostatique  
*Shower set*  
Duschkombination

**170** CONTEMPORAINE

Design Alberto PINTO



OFF



# Le II by Alberto Pinto

à manettes

by   
CREATIONS  
Journé - Année 2012/2013  
PARIS



**Ref. U2B.151**

Mélangeur de lavabo 3 trous  
Rim mounted 3-hole basin mixer  
3-Loch-Waschtischbatterie



**Ref. U2B.544GM**

Coupe à poser  
Soap dish on stand  
Standseifenschale



**Ref. U2B.504N**

Anneau porte-serviette  
Single towel ring  
Handtuchring

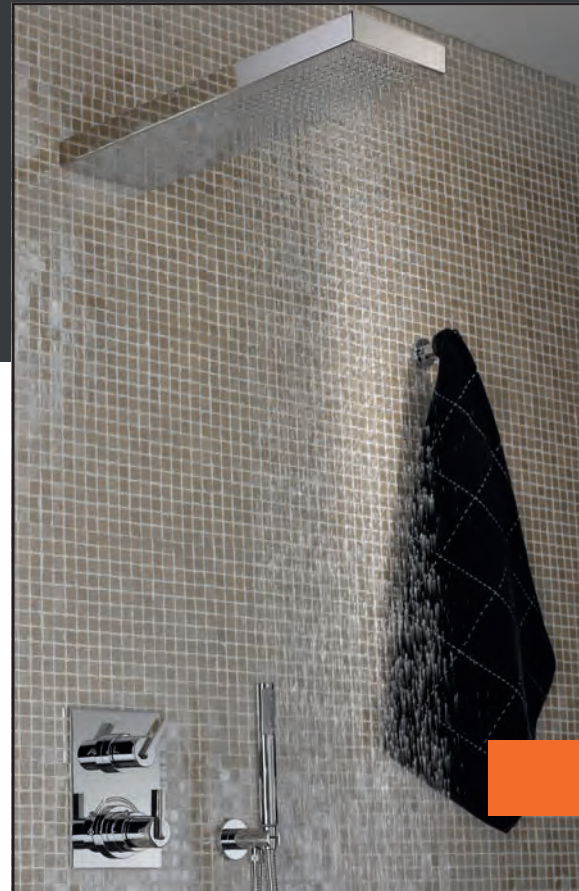

**Ref. U2B.5500B - 54 - 490**

Ensemble de douche - Pomme inox 535 x 160 mm  
Shower set - Stainless steel showerhead 535x160 mm / 21"x6"  
Duschkombination mit Brausekopf auf Edelstahl 535 x 160 mm

**Ref. U2B.6500**

Mitigeur de lavabo  
Single lever basin mixer  
Waschtisch-Einhebelmischer







**Ref. U2K.151**  
 Mélangeur de lavabo  
 Basin set  
 Waschtischbeckenmischer



**Ref. U2K.6500**  
 Mitigeur de lavabo monotrou  
 Single lever basin mixer  
 Waschtisch-Einhebelmischer

**Ref. U2K.6500H**  
 Mitigeur de lavabo monotrou, grand modèle  
 Single lever basin mixer, big size  
 Waschtisch-Einhebelmischer, großes Modell

**Ref. U2K.151/P**  
 Mélangeur de lavabo 3 trous sur plaque  
 Plate-mounted 3 hole basin mixer  
 Waschtischbeckenmischer auf Platte eingebaut

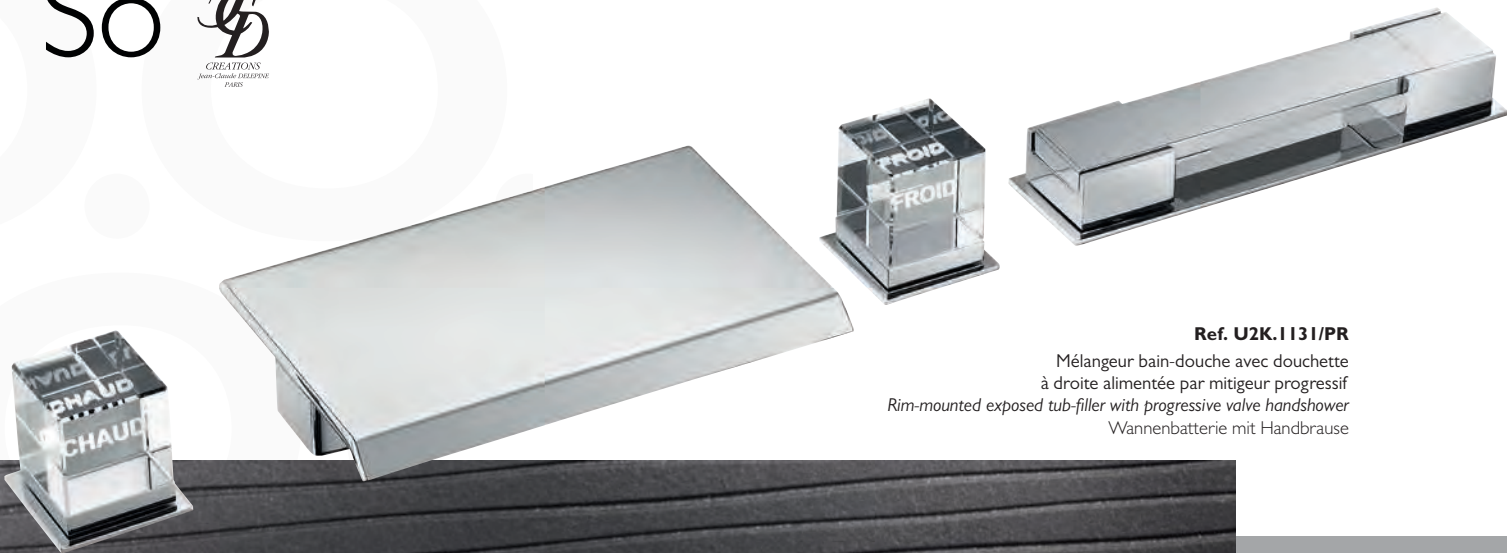

**Ref. U2K.1131/PR**

Mélangeur bain-douche avec douchette à droite alimentée par mitigeur progressif  
 Rim-mounted exposed tub-filler with progressive valve handshower  
 Wannenbatterie mit Handbrause

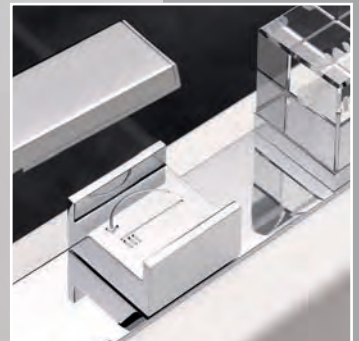

**Ref. U2K.1131/PL**

Mélangeur bain-douche sur plaque avec douchette à gauche alimentée par mitigeur progressif  
 Plate mounted exposed tub-filler with progressive valve handshower  
 Wannenbatterie auf Platte eingebaut mit Handbrause

**Ref. U2K.5400D/B - 490**

Ensemble de douche thermostatique - Pomme inox 535 x 160 mm  
 Shower set - Stainless steel showerhead 535x160 mm / 21"x6"  
 Duschkombination - Brausekopf auf Edelstahl 535 x 160 mm



Design Oliver GOSSART

CONTEMPORAINE 177





178

CONTEMPORAINE

# Profil métal

by   
CRÉATIONS  
Jean-Claude MILLON  
PARIS



Design Jamie DRAKE

CONTEMPORAINE

179



# Profil métal

by   
CREATIONS  
Paris - Créteil - 1932/2002  
France

 180 CONTEMPORAINE





**Ref. A6B.5500 - 54 - 490**

Ensemble de douche thermostatique - Pomme inox 535 x 160 mm  
Thermostat shower set - Stainless steel showerhead 535x160 mm / 21"x6"  
Duschkombination - Brausekopf auf Edelstahl 535 x 160 mm



**Ref. A6A.151**

Mélangeur de lavabo 3 trous  
Rim mounted 3-hole basin mixer  
3-Loch-Waschtischbatterie

Disponible aussi en version manettes - A6B  
Also available with lever handles - A6B  
Verfügbar auch mit Hebelgriffen - A6B





**Ref. A6N.151**  
Mélangeur de lavabo 3 trous  
Rim mounted 3-hole basin mixer  
3-Loch-Waschtischbatterie



**Ref. A6P.6500**  
Mitigeur de lavabo  
Single lever basin mixer  
Wäschtlisch-  
Einhebelmischer

# Profil

by   
*onyx noir*



**Ref. A6P.151**  
Mélangeur de lavabo 3 trous - Onyx noir  
*Rim mounted 3-hole basin mixer - Black onyx*  
3-Loch-Waschtischbatterie - Schwarzer Onyx

**Ref. A6P.112BSG**  
Mélangeur bain-douche 4 trous sur gorge  
*Rim mounted 4-hole bath-shower mixer*  
4-Loch-Wannenfüll- und Brausebatterie



# Marina métal

design  
  
CRÉATIONS  
Jean-Claude MÉRIEUX  
PARIS



**Ref. A61.6500P**  
Mitigeur de lavabo monotrou  
Single lever basin mixer  
Waschtisch-Einhebelmischer





**Ref. A61.546GM**  
Coupe porte-savon murale  
Wall mounted soap dish  
Wandseifenschale



**Ref. A61.504N**  
Anneau porte-serviette  
Single towel ring  
Handtuchring

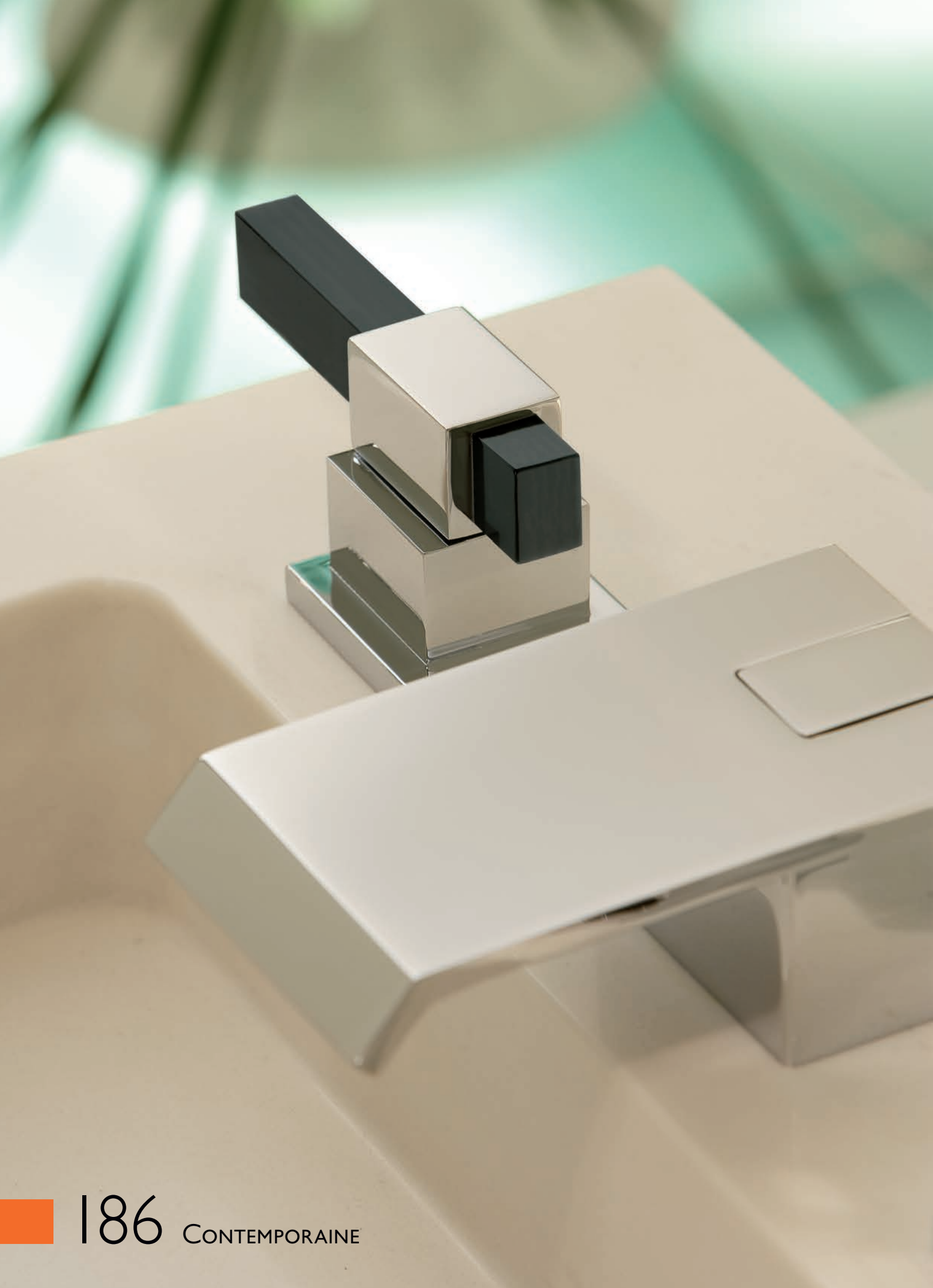



 186 CONTEMPORAINE

# Marina

onyx noir

design  
  
CREATIONS  
Jean-Claude GAZDAR  
PARIS

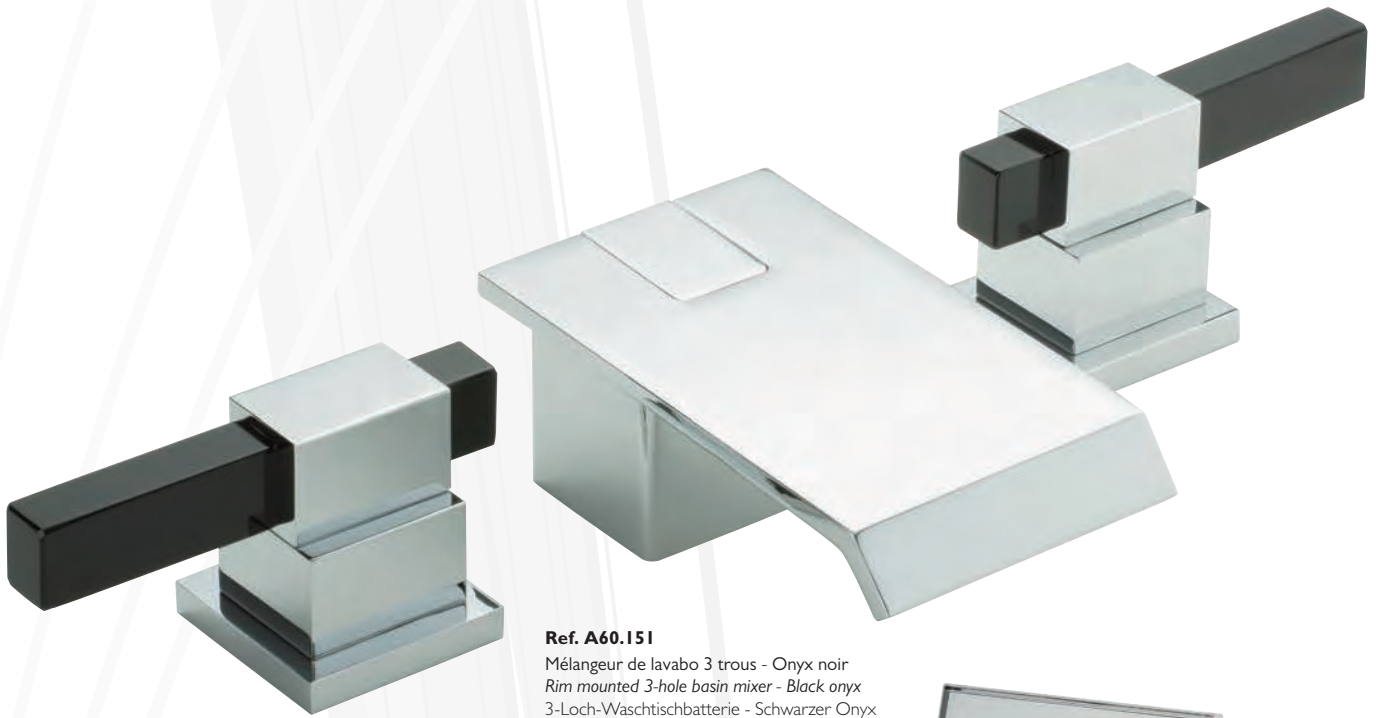

**Ref. A60.151**

Mélangeur de lavabo 3 trous - Onyx noir  
Rim mounted 3-hole basin mixer - Black onyx  
3-Loch-Waschtischbatterie - Schwarzer Onyx



**Ref. A60.29NIA/D**

Bec de bain sur gorge 400 mm  
Rim mounted waterfall bath spout 400 mm / 16"  
Wasserfall-Wannenauslauf zur Standmontage 400 mm



**Ref. G00.666**  
Miroir à poser  
Free standing mirror  
Kosmetikspiegel

**Ref. A60.151**

Mélangeur de lavabo 3 trous / Rim mounted 3-hole basin mixer / 3-Loch-Waschtischbatterie

CONTEMPORAINE

187



# Beluga



**Ref. GIT.6500D**

Mitigeur de lavabo monotrou, moyen modèle  
Single lever basin mixer, medium size  
Waschtisch-Einhebelmischer, mittleres Modell

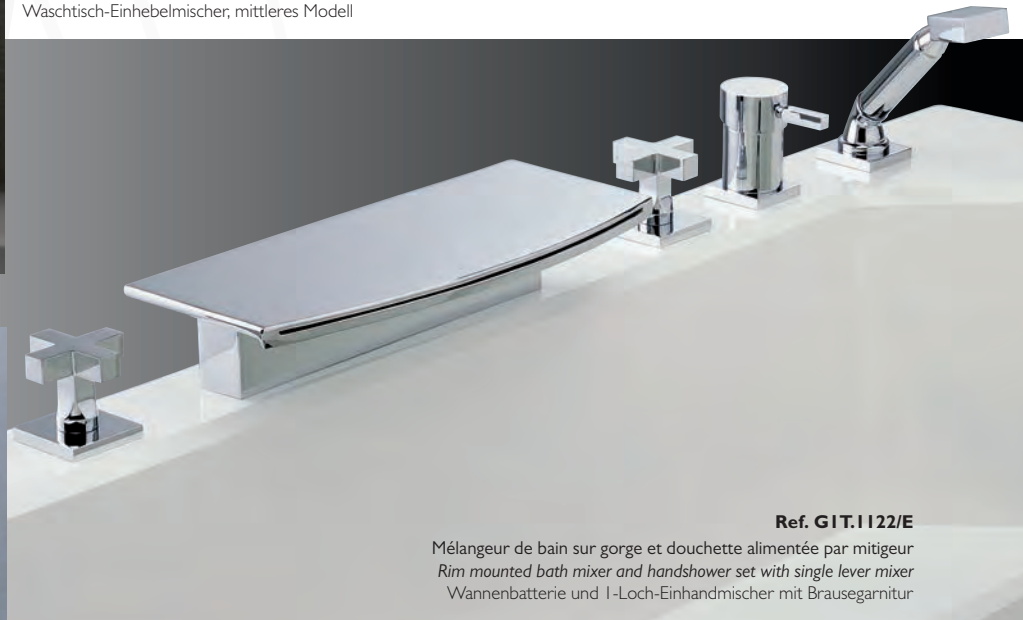

**Ref. GIT.1122/E**

Mélangeur de bain sur gorge et douchette alimentée par mitigeur  
Rim mounted bath mixer and handshower set with single lever mixer  
Wannenbatterie und 1-Loch-Einhandmischer mit Brausegarnitur



**Ref. GIT.500**

Porte-savon mural  
Wall mounted glass soap dish  
Seifenschale zur Wandmontage



**Ref. GIT.536**

Porte-verre mural  
Wall mounted tumbler  
Wandglashalter mit Glas

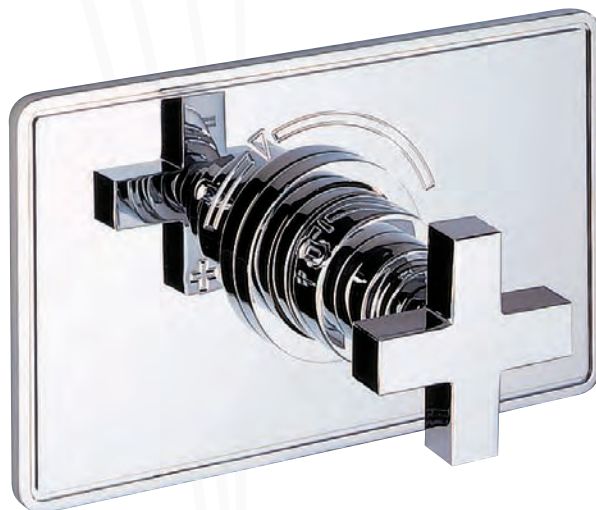

**Ref. GIT.5100B**

Garniture pour mitigeur thermostatique  
Trim for thermostat  
Thermostat-Garnitur





# Beluga à manettes

**Ref. GIU.6527CD**

Ensemble de douche thermostatique  
*Wall mounted shower thermostatic set*  
Thermostat-Duschbatterie



**Ref. GIU.40G**

Mélangeur de lavabo 3 trous mural  
*Wall mounted basin set*  
3-Loch-Waschtischbatterie  
zur Wandmontage



**Ref. GIU.113BG**

Mitigeur bain-douche 3 trous sur gorge  
*Rim mounted 3-hole bath-shower mixer*  
3-Loch-Wannenfüll und Brausebatterie



**Ref. GIU.4702**

Ensemble pot à balai en verre à poser  
*Free standing toilet brush set*  
WC-Bürstentopfgarnitur



CONTEMPORAINE 191



# Pure



**Ref. G04.153**

Mélangeur de lavabo 3 trous, modèle à manettes  
*Rim mounted 3-hole basin mixer with lever handles*  
3-Loch-Waschtischbatterie mit Hebelgriffen

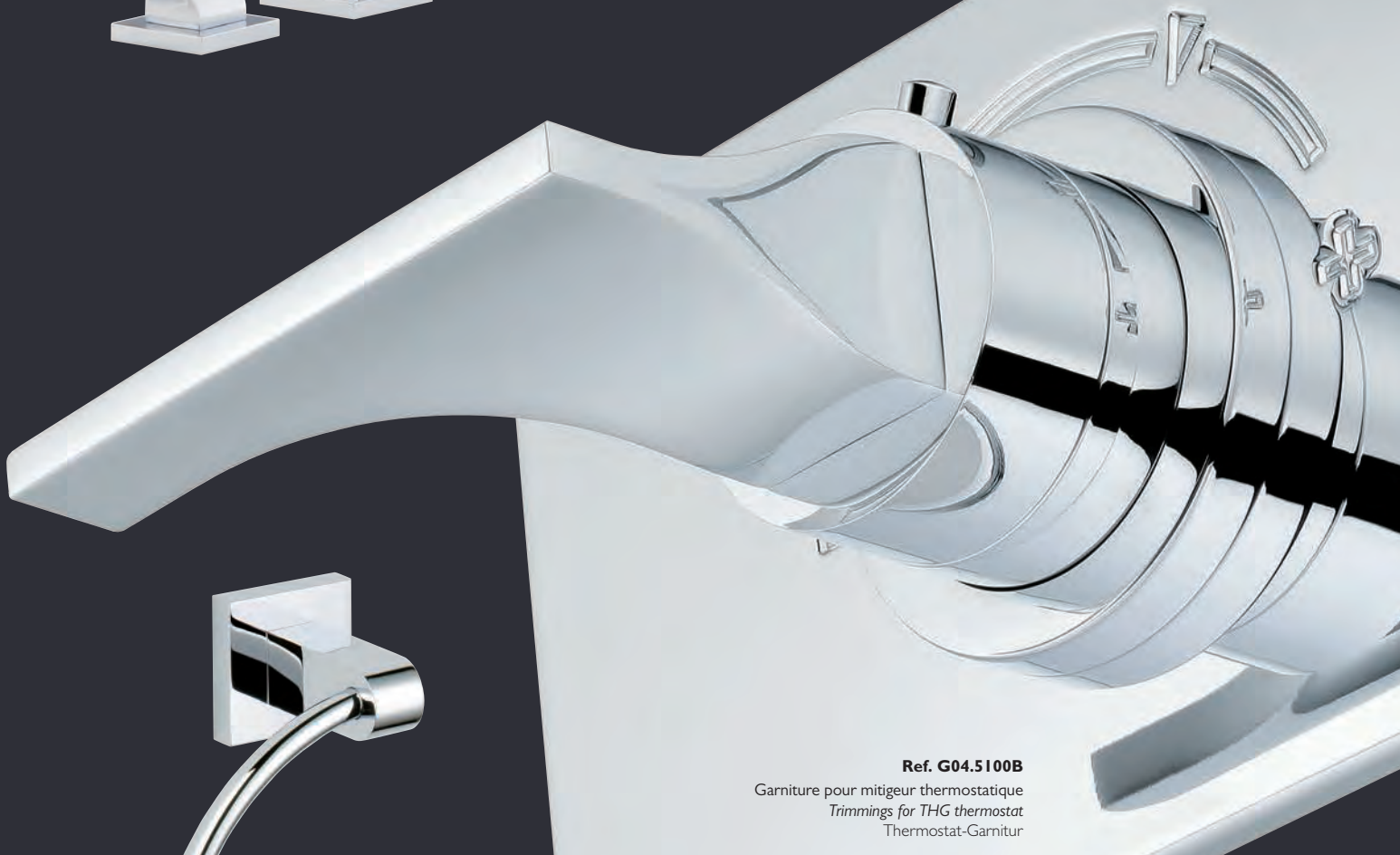

**Ref. G04.5100B**

Garniture pour mitigeur thermostatique  
*Trimings for THG thermostat*  
Thermostat-Garnitur



**Ref. G04.504N**

Anneau porte-serviette  
*Single towel ring*  
Handtuchring





# CLASSIQUE



Frivole . 196  
Froufrou . 198  
Faubourg . 200  
Mandarine . 206  
Mandarine Cristal . 208  
Mandarine Cristallia . 212  
Najem . 214

Diplomate . 216  
Diplomate Royale . 222  
Beverley . 224  
Cubica . 226  
Vendôme . 228  
Spirit . 230



**Ref. G2R.152**

Mélangeur de lavabo 3 trous bec haut  
*Rim mounted 3-hole basin mixer with high spout*  
3-Loch-Waschtischbatterie mit hohem Auslauf



**Ref. G2S.41SG**

Mélangeur de bain 3 trous mural  
*Wall mounted 3-hole bath mixer*  
3-Loch-Wannenfüllbatterie zur Wandmontage



**Ref. G2S.504N**

Anneau porte-serviette  
*Single towel ring*  
Handtuchring

**Ref. G2S.151**

Mélangeur de lavabo 3 trous / *Rim mounted 3-hole basin mixer* / 3-Loch-Waschtischbatterie



Design Pierre-Yves ROCHON

CLASSIQUE 197





198 CLASSIQUE

Design Pierre-Yves ROCHON



**Ref. G2N.112BSG**

Mélangeur bain-douche 4 trous sur gorge  
Rim mounted 4-hole bath-shower mixer  
4-Loch-Wannenfüll-und Brausebatterie



Disponible aussi en version à manettes - G2P  
Also available with lever handles - G2P  
Verfügbar auch mit Hebelgriffen - G2P



**Ref. G2N.543M**

Porte papier  
Paper roll holder  
Papierrollenhalter

**Ref. G2N.514/50**

Porte-serviette  
Single towel rail  
Handtuchstange



**Ref. G2N.13B**

Mélangeur bain-douche mural  
Wall mounted bath mixer and shower set  
Wannenwandbatterie



**Ref. G2N.546GM**

Coupe porte-savon murale  
Wall mounted soap dish  
Wandseifenschale

**Ref. G2N.151**

Mélangeur de lavabo 3 trous / Rim mounted 3-hole basin mixer / 3-Loch-Waschtischbatterie

# Faubourg porcelaine blanche

by   
CRÉATIONS  
Journé - Année 1922/1928  
PARIS

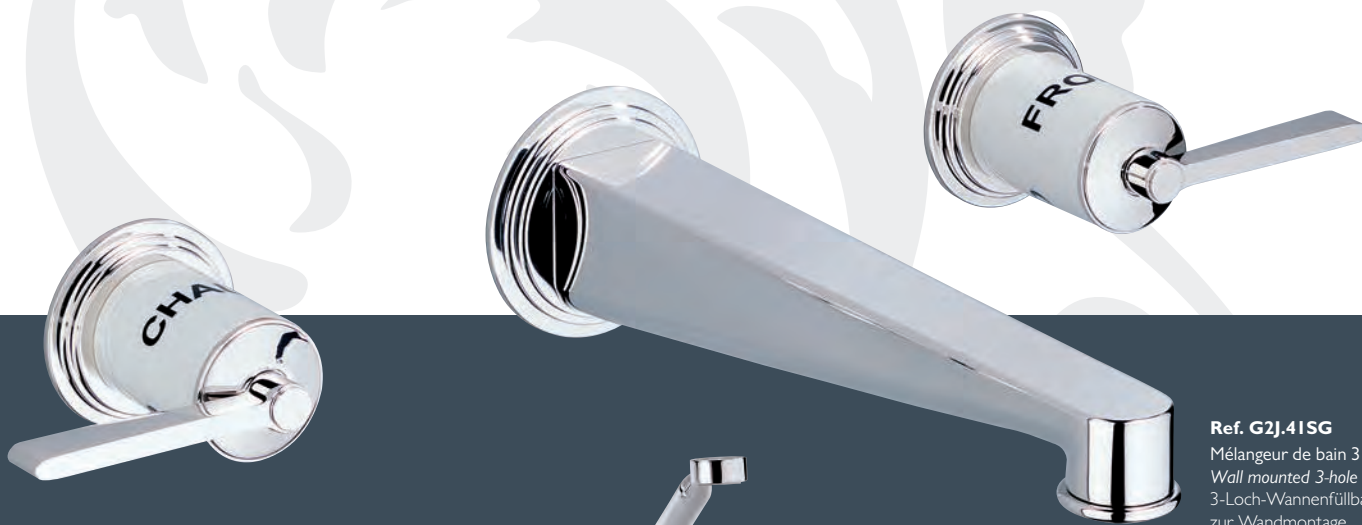

**Ref. G2J.41SG**  
Mélangeur de bain 3 trous mural  
Wall mounted 3-hole bath mixer  
3-Loch-Wannenfüllbatterie  
zur Wandmontage



**Ref. G2J.112BSG**  
Mélangeur bain-douche 4 trous sur gorge  
Rim mounted 4-hole bath-shower mixer  
4-Loch-Wannenfüll- und Brausebatterie



**Ref. G2J.6504**  
Mitigeur de bidet monotrou  
Single lever mono bidet mixer  
1-Loch-Bidetmischer



**Ref. G2J.6500**  
Mitigeur de lavabo monotrou  
Single lever basin mixer  
Waschtisch-Einhebelmischer



**Ref. G2J.504N**  
Anneau porte-serviette  
Single towel ring  
Handtuchring



Disponible aussi en version croisillons - G2K  
Also available with knob handles - G2K  
Verfügbar auch mit Bedienungsgriffen - G2K

200 CLASSIQUE

**Ref. G2J.151**  
Mélangeur de lavabo 3 trous / Rim mounted 3-hole basin mixer / 3-Loch-Waschtischbatterie



Design Pierre-Yves ROCHON

CLASSIQUE 201



202 CLASSIQUE

Design Pierre-Yves ROCHON

# Faubourg porcelaine noire

by  
G2  
CREATIONS  
Jean-Claude COLLETTI  
PARIS



**Ref. G2L.6500**  
Mitigeur de lavabo monotrou  
Single lever basin mixer  
Waschtisch-Einhebelmischer



**Ref. G2L.113BSG**  
Mitigeur bain-douche 3 trous sur gorge  
Rim mounted 3-hole bath-shower mixer  
3-Loch-Wannenfüll- und Brausebatterie



**Ref. G2L.3202**  
Mélangeur de bidet monotrou à rotule  
Single lever mono bidet mixer and pop-up waste  
1-Loch-Zweigriff-Bidetbatterie



**Ref. G2L.4720C**  
Ensemble pot à balai mural  
Wall mounted WC brush with cover  
WC-Bürstentopf-garnitur



**Ref. G2L.41SG**  
Mélangeur de bain 3 trous mural  
Wall mounted 3-hole bath mixer  
3-Loch-Wannenfüllbatterie zur Wandmontage



**Ref. G2L.517**  
Porte-peignoir  
Robe hook ball  
Bademantelhaken

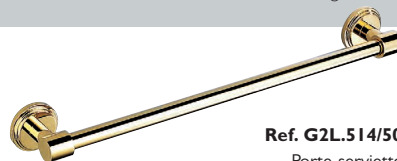

**Ref. G2L.514/50**  
Porte-serviette  
Single towel rail  
Handtuchstange

Disponible aussi en version à manettes - G2M  
Also available with lever handles - G2M  
Verfügbar auch mit Hebelgriffen - G2M

# Faubourg métal

by  
**GD**  
CREATIONS  
Journé - Châssis - Mécanisme  
PARIS



**Ref. G2U.13B**

Mélangeur bain-douche mural  
Wall mounted bath mixer and shower set  
Wannenwandbatterie

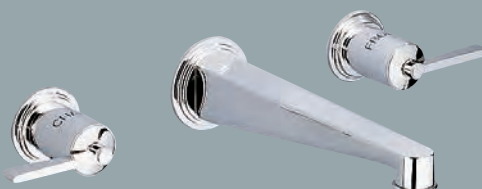

**Ref. G2U.41SG**

Mélangeur de bain 3 trous mural  
Wall mounted 3-hole bath mixer  
3-Loch-Wannenfüllbatterie zur Wandmontage



**Ref. G2U.6500**

Mitigeur de lavabo monotrou  
Single lever basin mixer  
Waschtisch-Einhebelmischer



**Ref. G2U.543M**

Porte papier  
Paper roll holder  
Papierrollenhalter



**Ref. G2U.546GM**

Coupe porte-savon murale  
Wall mounted soap dish  
Wandseifenschale



**Ref. G2U.4720C**

Ensemble pot à balai mural  
Wall mounted WC brush with cover  
WC-Bürstentopf-garnitur

**Ref. G2U.151**

Mélangeur de lavabo 3 trous / Rim mounted 3-hole basin mixer / 3-Loch-Waschtischbatterie

Disponible aussi en version croisillons - G2T  
Also available with knob handles - G2T  
Verfügbar auch mit Bedienungsriffen - G2T



Design Pierre-Yves ROCHON

CLASSIQUE 205





206 CLASSIQUE

Ref. UIA.151

Mélangeur de lavabo 3 trous / Rim mounted 3-hole basin mixer / 3-Loch-Waschtischbatterie

# Mandarine métal

design  
  
G. CREATIONS  
Jean Charles GILLESPIE  
PARIS



**Ref. UIA.504N**  
Anneau porte-serviette  
Single towel ring  
Handtuchring

**Ref. UIA.546GM**

Coupe murale  
Wall mounted soap dish  
Wandseifenschale



**Ref. UIA.2155**

Mélangeur de lavabo monotrou  
Rim mounted one hole basin mixer  
1-Loch-Zweigriff-Waschtischbatterie

CLASSIQUE 207



208 CLASSIQUE

# Mandarine

*crystal*

design  
  
CREATIONS  
Jean-Claude DELZENNE  
PARIS



**Ref. UID.151**

Mélangeur de lavabo 3 trous - Cristal clair  
*Rim mounted 3-hole basin mixer - Clear crystal*  
3-Loch-Waschtischbatterie - Klarer Kristall



**Ref. UIE.151**

Mélangeur de lavabo 3 trous - Cristal satiné  
*Rim mounted 3-hole basin mixer - Satin crystal*  
3-Loch-Waschtischbatterie - Satinierter Kristall

**Ref. UID.25SG**

Mélangeur de bain 3 trous sur gorge  
*Rim mounted 3-hole bath mixer*  
3-Loch-Wannenfüllbatterie zur Standmontage

CLASSIQUE 209

# Mandarine

*cristal*

design   
CREATONS  
Jean Charles HELLEPRE  
PARIS



**Ref. UID.40G**  
Mélangeur de lavabo 3 trous mural  
Wall mounted basin set  
3-Loch-Waschtischbatterie zur Wandmontage



**Ref. UID.504N**  
Anneau porte-serviette  
Single towel ring  
Handtuchring



**Ref. UID.546GM**  
Coupe murale  
Wall mounted soap dish  
Wandseifenschale



**Ref. UID.508**  
Porte-peignoir  
Single robe hook  
Bademantelhaken





**Ref. UID.151**

Mélangeur de lavabo 3 trous  
Rim mounted 3-hole basin mixer  
3-Loch-Waschtischbatterie

CLASSIQUE 211



**Ref. UIK.151**

Mélangeur de lavabo 3 trous  
Rim mounted 3-hole basin mixer  
3-Loch-Waschtischbatterie

212 CLASSIQUE

# Mandarine

*cristallia diamant*

design  
  
GREATEONS  
Jean Charles GILLESPIE  
PARIS



**Ref. UIK.546GM**  
Coupe murale  
Wall mounted soap dish  
Wandseifenschale



**Ref. UIK.3202**  
Mélangeur de bidet monotrou à rotule  
Rim mounted one hole bidet mixer  
1-Loch-Zweigriff-Bidetbatterie



**Ref. UIK.2155**  
Mélangeur de lavabo monotrou  
Rim mounted one hole basin mixer  
1-Loch-Zweigriff-Waschtischbatterie



**Ref. UIK.504N**  
Anneau porte-serviette  
Single towel ring  
Handtuchring



# Najem



**Ref. E53.504N**  
Anneau porte-serviette  
Single towel ring  
Handtuchring



**Ref. E53.538AC**  
Porte-papier  
Wall mounted WC paper holder  
WC-Papierhalter





**Ref. E53.151**

Mélangeur de lavabo 3 trous  
Rim mounted 3-hole basin mixer  
3-Loch-Waschtischbatterie

CLASSIQUE 215

# Diplomate

*bagues lisses*

design  
  
CREATIONS  
Avec un savoir-faire  
1982

**Ref. U4A.2155**

Mélangeur de lavabo monotrou  
*Rim mounted one hole basin mixer*  
I-Loch-Zweigriff-Waschtischbatterie



**Ref. U4A.538AC**

Porte-papier  
*Wall mounted WC paper holder*  
WC-Papierhalter



**Ref. U4A.546GM**

Coupe murale  
*Wall mounted soap dish*  
Wandseifenschale



216 CLASSIQUE



**Ref. U4A.151**

Mélangeur de lavabo 3 trous  
Rim mounted 3-hole basin mixer  
3-Loch-Waschtischbatterie

CLASSIQUE 217



**Ref. U4B.151**

Mélangeur de lavabo 3 trous

Rim mounted 3-hole basin mixer

3-Loch-Waschtischbatterie

**218** CLASSIQUE

# Diplomate

*bagues annelées*

design  
  
CRÉATIONS  
Jean-Claude MULLER  
PARIS



**Ref. U4B.3202**

Mélangeur de bidet monotrou à rotule  
Rim mounted one hole bidet mixer  
1-Loch-Zweigriff-Bidetbatterie



**Ref. U4B.546GM**

Coupe murale  
Wall mounted soap dish  
Wandseifenschale



**Ref. U4B.538AC**

Porte-papier  
Wall mounted WC paper holder  
WC-Papierhalter



CLASSIQUE 219

# Diplomate

*bagues torsadées*

design  
  
GREGATIONS  
Jean-Claude GREGATIONS  
PARIS

**Ref. U4C.5400B**

Garniture pour mitigeur thermostatique avec 2 robinets d'arrêt  
*Trim for thermostat with 2 valves*  
Thermostat-Garnitur mit 2 Absperrungen



**Ref. U4C.514**

Porte-serviette  
*Single towel rail*  
Handtuchstange



**Ref. U4C.52**

Ensemble de douche  
*Shower set*  
Duschkombination



220 CLASSIQUE

**Ref. U4C.151**

Mélangeur de lavabo 3 trous  
*Rim mounted 3-hole basin mixer*  
3-Loch-Waschtischbatterie



CLASSIQUE 221



# Diplomate royale

design  
  
CREATIONS  
Jean-Charles DELAUNAY  
PARIS

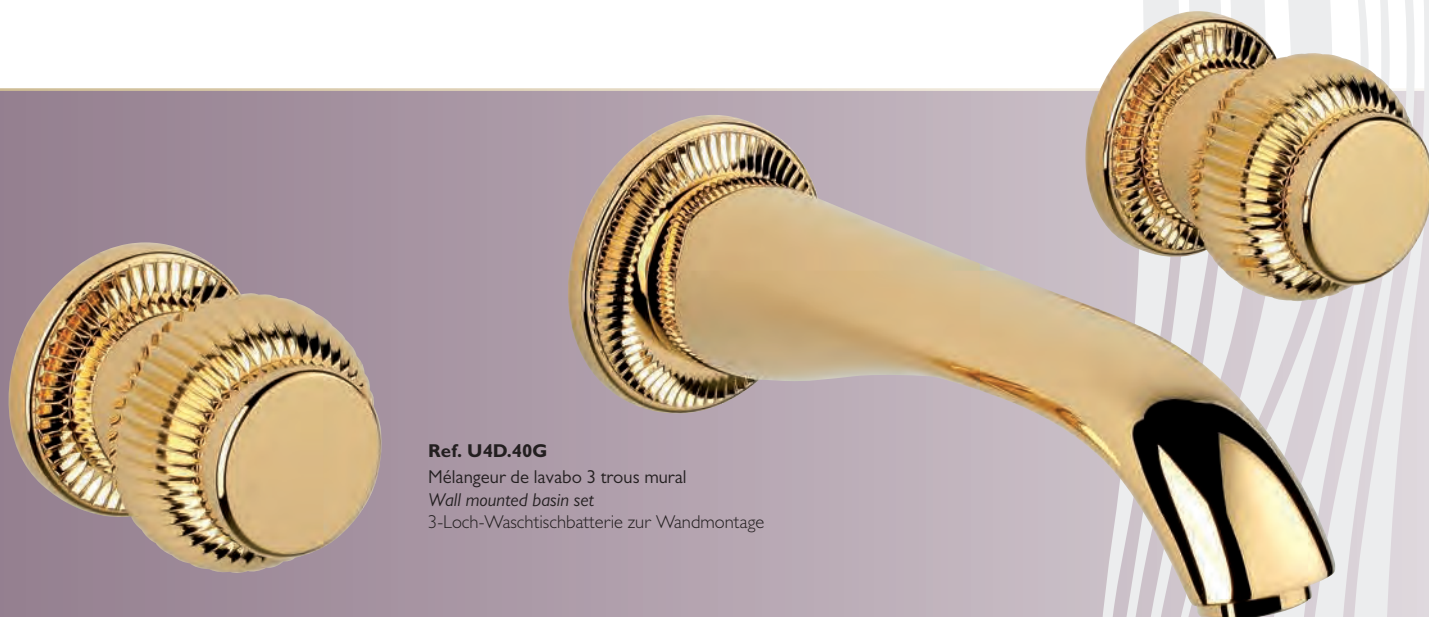

**Ref. U4D.40G**

Mélangeur de lavabo 3 trous mural  
Wall mounted basin set  
3-Loch-Waschtischbatterie zur Wandmontage



**Ref. U4D.517**

Porte-peignoir  
Robe hook ball  
Bademantelhaken

222 CLASSIQUE

**Ref. U4D.151**

Mélangeur de lavabo 3 trous  
Rim mounted 3-hole basin mixer  
3-Loch-Waschtischbatterie



CLASSIQUE 223



224 CLASSIQUE

# Beverley

**Ref. J17.4720**

Ensemble pot à balai mural  
Wall mounted WC brush set  
WC-Bürstentopf-garnitur



**Ref. J17.538AC**

Porte-papier  
Wall mounted WC paper holder  
WC-Papierhalter



**Ref. J17.2155**

Mélangeur de lavabo monotrou  
Rim mounted one hole basin mixer  
1-Loch-Zweigriff-Waschtischbatterie



**Ref. J17.112BG**

Mélangeur bain-douche 4 trous sur gorge  
Rim mounted 4-hole bath-shower mixer  
4-Loch-Wannenfüll- und Brausebatterie

**Ref. J17.151**

Mélangeur de lavabo 3 trous  
Rim mounted 3-hole basin mixer  
3-Loch-Waschtischbatterie



226

CLASSIQUE

# Cubica



**Ref. G79.40G**  
Mélangeur de lavabo 3 trous mural  
Wall mounted basin set  
3-Loch-Waschtischbatterie zur Wandmontage



**Ref. G79.2155**  
Mélangeur de lavabo monotrou  
Rim mounted one hole basin mixer  
1-Loch-Zweigriff-Waschtischbatterie



**Ref. G79.112BG**  
Mélangeur bain-douche 4 trous sur gorge  
Rim mounted 4-hole bath-shower mixer  
4-Loch-Wannenfüll-und Brausebatterie



**Ref. G79.504N**  
Anneau porte-serviette  
Single towel ring  
Handtuchring



**Ref. G79.4720**  
Ensemble pot à balai mural  
Wall mounted WC brush set  
WC-Bürstentopf-garnitur

**Ref. G79.151**  
Mélangeur de lavabo 3 trous / Rim mounted 3-hole basin mixer / 3-Loch-Waschtischbatterie

# Vendôme



**Ref. G47.514**  
Porte-serviette  
Single towel rail  
Handtuchstange

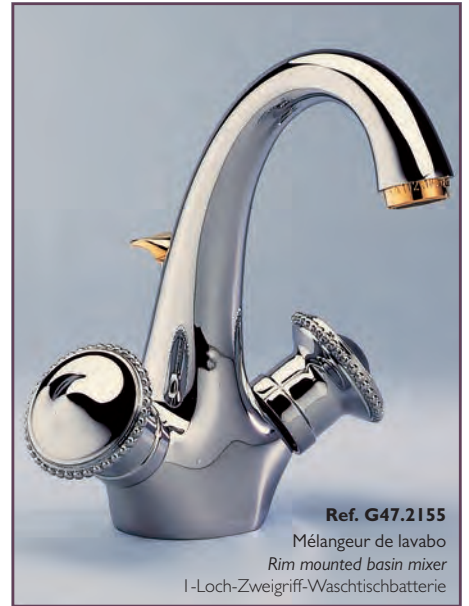

**Ref. G47.2155**  
Mélangeur de lavabo  
Rim mounted basin mixer  
1-Loch-Zweigriff-Waschtischbatterie



**Ref. G47.112BSG**  
Mélangeur bain-douche 4 trous sur gorge  
Rim mounted 4-hole bath-shower mixer  
4-Loch-Wannenfüll- und Brausebatterie



**Ref. G47.3202**  
Mélangeur de bidet à rotule  
Rim mounted bidet mixer  
1-Loch-Zweigriff-Bidetbatterie

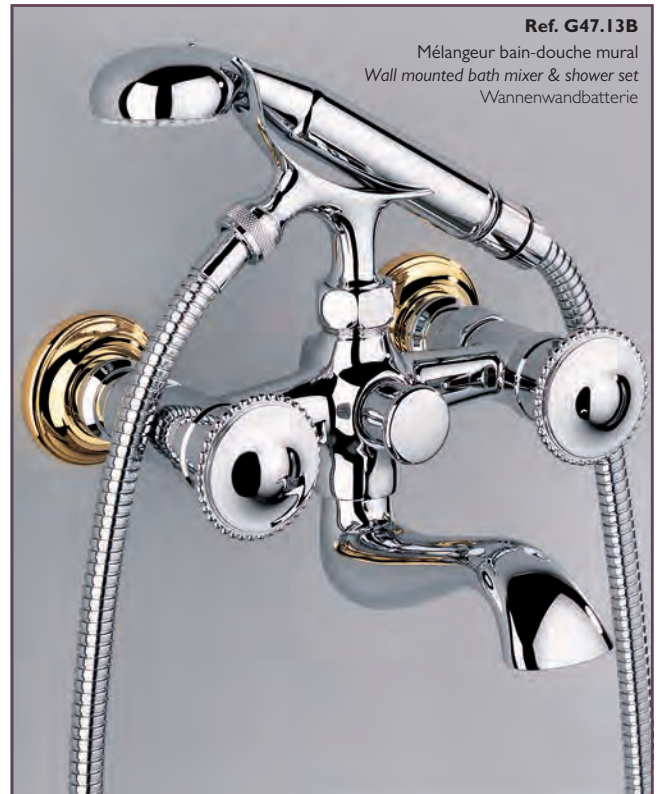

**Ref. G47.13B**  
Mélangeur bain-douche mural  
Wall mounted bath mixer & shower set  
Wannenwandbatterie



**Ref. G47.538AC**  
Porte-papier  
Wall mounted WC paper holder  
WC-Papierhalter

**Ref. G47.4720C**  
Ensemble pot à balai mural  
Wall mounted WC brush set  
WC-Bürstentopf-garnitur



**Ref. G47.151**

Mélangeur de lavabo 3 trous  
Rim mounted 3-hole basin mixer  
3-Loch-Waschtischbatterie

CLASSIQUE 229



# Spirit



**Ref. G69.41SG**

Mélangeur de bain 3 trous mural  
Wall mounted 3-hole bath mixer  
3-Loch-Wannenfüllbatterie zur Standmontage



**Ref. G69.113BSG**

Mitigeur de bain-douche 3 trous sur gorge  
Rim mounted 3-hole bath-shower mixer  
3-Loch-Wannenfüll-und Brausebatterie



**Ref. G69.504N**

Anneau porte-serviette  
Single towel ring  
Handtuchring

**Ref. G69.4720C**

Ensemble pot à balai mural  
Wall mounted WC brush with cover  
WC-Bürstentopf garnitur



**Ref. G69.151**

Mélangeur de lavabo 3 trous / Rim mounted 3-hole basin mixer / 3-Loch-Waschtischbatterie

230 CLASSIQUE



CLASSIQUE 231



# Spirit à manettes



**Ref. G58.620A**  
Porte-savon fil mural  
Net soap dish  
Wandseifenkorb



**Ref. G58.546GM**  
Coupe murale  
Wall mounted soap dish  
Wandseifenschale



**Ref. G58.40SG**  
Mélangeur de lavabo 3 trous mural  
Wall mounted basin set  
3-Loch-Waschtischbatterie zur Wandmontage



**Ref. G58.6580SG**  
Mitigeur bain-douche mural à encastrer  
Wall mounted bath-shower mixer  
Unterputz-Einhandmischer, Wannenfüll- und Brausebatterie zur Wandmontage



**Ref. G58.504N**  
Anneau porte-serviette  
Single towel ring  
Handtuchring



**Ref. G58.514/50**  
Porte-serviette  
Single towel rail  
Handtuchstange

**Ref. G58.151**  
Mélangeur de lavabo 3 trous / Rim mounted 3-hole basin mixer / 3-Loch-Waschtischbatterie



# TRADITIONNELLE



1900 .	236
Charleston .	242
Art Déco .	248
Tradition .	254
Broadway .	260
Pompadour .	264

1900

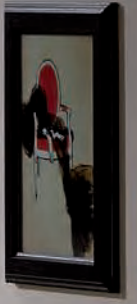

236 TRADITIONNELLE







238 TRADITIONNELLE

Ref. G25.13700

Mélangeur bain-douche sur colonnes  
F/S 2 hole bath/telephone shower mixer  
Freistehende Wannenfüll- und  
Brausebatterie

# 1900



**Ref. G25.564**

Tablette Securit Lg 60 cm, avec supports  
Glass shelf 60 cm with supports  
Glasablage 600 mm mit Halterung



**Ref. G25.151**

Mélangeur de lavabo 3 trous  
Rim mounted 3-hole basin mixer  
3-Loch-Waschtischbatterie



**Ref. G25.2155**

Mélangeur de lavabo monotrou  
Rim mounted one hole basin mixer  
1-Loch-Zweigriff-Waschtischbatterie



**Ref. G25.161**

Mélangeur pour lave-mains  
Rim mounted washbasin mixer  
Zweigriff-Waschtischbatterie

# 1900 à manettes



**G28.151 + Ref. 912 (x2)**

Mélangeur de lavabo 3 trous - Manettes métal lisses  
Rim mounted 3-hole basin mixer - Smooth metal lever handles  
3-Loch-Waschtischbatterie mit glatten Metallhebelgriffen



**Ref. G28.159**

Mélangeur de lavabo  
Rim mounted basin mixer  
Waschtischbatterie



**Ref. G28.175/H + G28.175/C**

Robinet de lavabo  
Rim mounted pillar tap  
1-Loch-Standventil



**Ref. G28.13B**

Mélangeur bain-douche mural  
Wall mounted bath mixer  
Wannenwandbatterie



**Ref. G28.112BG**

Mélangeur bain-douche 4 trous  
Rim mounted 4-hole bath-shower mixer  
4-Loch-Wannenfüll- und Brausebatterie



**Ref. G28.514**

Porte-serviette  
Single towel rail  
Handtuchstange



**G28.151 + 2x Ref. 913**

Mélangeur de lavabo 3 trous - Manettes métal torsadées  
Rim mounted 3-hole basin mixer - Twisted metal lever handles  
3-Loch-Waschtischbatterie mit Metallhebelgriffen - Kordel

**Ref. G28.151**

Mélangeur de lavabo 3 trous  
Rim mounted 3-hole basin mixer  
3-Loch-Waschtischbatterie





242 TRADITIONNELLE

# Charleston





# Charleston



**Ref. G29.504N**  
Anneau porte-serviette  
Single towel ring  
Handtuchring



**Ref. G29.152**  
Mélangeur de lavabo 3 trous - Bec haut  
Rim mounted 3-hole basin mixer - High spout  
3-Loch-Waschtischbatterie mit hohem Auslauf



**Ref. G29.112BGBB**  
Mélangeur bain-douche 4 trous sur gorge  
Rim mounted 4-hole bath-shower mixer  
4-Loch-Wannenfüll- und Brausebatterie



**Ref. G29.64TRD**  
Ensemble thermostatique de douche avec pomme de douche anti-calcaire Ø 220 mm  
Wall mounted shower thermostat set with shower head Ø 220 mm / 8 3/4"  
Thermostat-Duschbatterie mit Brausekopf Ø 220 mm mit Antikalksystem



**Ref. G29.2155**  
Mélangeur de lavabo monotrou  
Rim mounted one hole basin mixer  
1-Loch-Zweigriff-Waschtischbatterie

**Ref. G29.151**  
Mélangeur de lavabo 3 trous / Rim mounted 3-hole basin mixer / 3-Loch-Waschtischbatterie



# Charleston

## à manettes



### Ref. G75.64TRD

Ensemble thermostatique de douche avec pomme de douche anti-calcaire Ø 220 mm  
 Wall mounted shower thermostat set with shower head Ø 220 mm / 8 3/4"  
 Thermostat-Duschbatterie mit Brausekopf Ø 220 mm mit Antikalksystem



### Ref. G75.112BSGBH

Mélangeur bain-douche 4 trous  
 Rim mounted 4-hole bath-shower mixer  
 4-Loch-Wannenfüll- und Brausebatterie



### Ref. G75.151

Mélangeur de lavabo 3 trous  
 Rim mounted 3-hole basin mixer  
 3-Loch-Waschtischbatterie



### Ref. G75.13B

Mélangeur bain-douche mural  
 Wall mounted bath mixer and shower set  
 Wannenwandbatterie



### Ref. G75.538AC

Porte-papier  
 Wall mounted WC paper holder  
 WC-Papierhalter



### Ref. G75.912

Manette métal lisse  
 Smooth metal lever handle  
 Glatter Metallhebelgriff



### Ref. G75.913

Manette métal torsadée  
 Twisted metal lever handle  
 Metallhebelgriff – Kordel

### Ref. G75.13700

Mélangeur bain-douche sur colonnes  
 Free standing 2 hole bath/telephone shower mixer  
 Freistehende Wannenfüll- und Brausebatterie



TRADITIONNELLE 247



**Ref. A54.152**

Mélangeur de lavabo 3 trous - Bec haut  
Rim mounted 3-hole basin mixer - High spout  
3-Loch-Waschtischbatterie mit hohem Auslauf



**Ref. A54.504N**

Anneau porte-serviette  
Single towel ring  
Handtuchring



**Ref. A54.151**

Mélangeur de lavabo 3 trous  
Rim mounted 3-hole basin mixer / 3-Loch-Waschtischbatterie





250

TRADITIONNELLE

# Art Déco

design  
  
CREATIONS  
Jean-Claude DELZENNE  
PARIS

## à manettes



**Ref. A55.152**

Mélangeur de lavabo 3 trous - Bec haut  
*Rim mounted 3-hole basin mixer - High spout*  
3-Loch-Waschtischbatterie mit hohem Auslauf



**Ref. A55.151**

Mélangeur de lavabo 3 trous  
*Rim mounted 3-hole basin mixer*  
3-Loch-Waschtischbatterie



**Ref. A55.112BSG**

Mélangeur bain-douche 4 trous  
*Rim mounted 4-hole bath-shower mixer*  
4-Loch-Wannenfüll- und Brausebatterie

**Ref. A55.41SG**

Mélangeur de bain 3 trous mural / *Wall mounted 3-hole bath mixer*  
3-Loch-Wannenfüllbatterie zur Wandmontage

TRADITIONNELLE

# 251

# Art Déco

design  
  
CREATIONS  
Jean-Claude DELZENNE  
PARIS

## cristal



**Ref. A56.151**

Mélangeur de lavabo 3 trous  
Rim mounted 3-hole basin mixer  
3-Loch-Waschtischbatterie



**Ref. A56.152**

Mélangeur de lavabo 3 trous - Bec haut  
Rim mounted 3-hole basin mixer - High spout  
3-Loch-Waschtischbatterie mit hohem Auslauf



**Ref. A56.520**

Porte-serviette  
Single towel rail  
Handtuchstange

**Ref. A56.84**  
**Ref. A56.286**  
**Ref. A56.15EN16EM**  
**Ref. A56.40SG**

Ensemble bain-douche thermostatique  
Thermostat wall-mounted set  
Duschkombination zur Wandmontage

252 TRADITIONNELLE



TRADITIONNELLE

253







**Ref. A57.152**

Mélangeur de lavabo 3 trous - Bec haut  
Rim mounted 3-hole basin mixer - High spout  
3-Loch-Waschtischbatterie mit hohem Auslauf

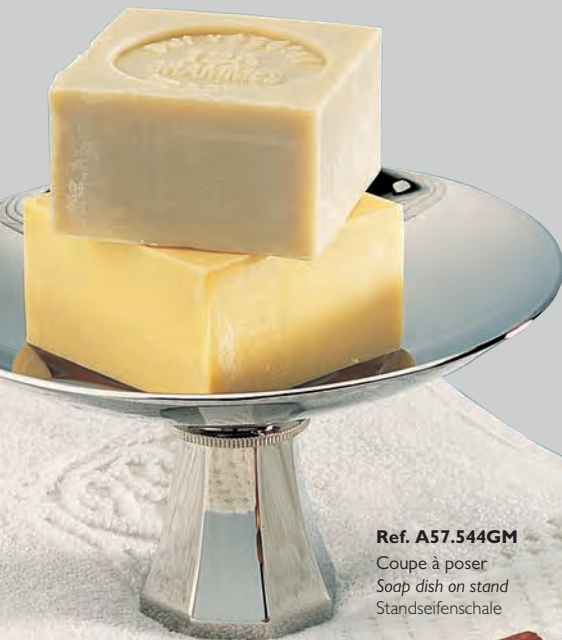

**Ref. A57.544GM**

Coupe à poser  
Soap dish on stand  
Standseifenschale



**Ref. A57.13B**

Mélangeur bain-douche mural  
Wall mounted bath mixer and shower set  
Wannenwandbatterie



**Ref. A57.13G**

Mélangeur bain-douche sur gorge  
Rim mounted bath mixer and shower set  
Wannenstandbatterie



**Ref. A57.620A**

Porte-savon fil mural  
Net soap dish  
Wandseifenkorb



TRADITIONNELLE 255





256 TRADITIONNELLE

# Tradition à manettes

design  
**CS**  
CREATIONS  
Jean-Claude DELZENNE  
PARIS



**Ref. A58.152**

Mélangeur de lavabo 3 trous - Bec haut  
Rim mounted 3-hole basin mixer - High spout  
3-Loch-Waschtischbatterie  
mit hohem Auslauf



**Ref. A58.546GM**

Coupe murale  
Wall mounted soap dish  
Wandseifenschale



**Ref. A58.517**

Porte-peignoir  
Robe hook ball  
Bademantelhaken

**Ref. A58.151**

Mélangeur de lavabo 3 trous / Rim mounted 3-hole basin mixer / 3-Loch-Waschtischbatterie

# Tradition design

CREATIONS  
Jean-Claude DELZENNE  
PARIS

## cristal



**Ref. A59.152**

Mélangeur de lavabo 3 trous - Bec haut  
Rim mounted 3-hole basin mixer - High spout  
3-Loch-Waschtischbatterie mit hohem Auslauf



**Ref. A59.25SG**

Mélangeur de bain 3 trous sur gorge  
Rim mounted 3-hole bath mixer  
3-Loch-Wannenfüllbatterie zur Standmontage



**Ref. A59.41SG**

Mélangeur de bain 3 trous mural  
Wall mounted 3-hole bath mixer  
3-Loch-Wannenfüllbatterie zur Wandmontage



**Ref. A59.504N**

Anneau porte-serviette  
Single towel ring  
Handtuchring



TRADITIONNELLE 259



**Ref. A52.151**

Mélangeur de lavabo 3 trous  
Rim mounted 3-hole basin mixer  
3-Loch-Waschtischbatterie

260 TRADITIONNELLE

# Broadway

design   
CREATIONS  
Journé - Qualité 181221010  
116825



**Ref. A52.2155**

Mélangeur de lavabo monotrou  
*Rim mounted one hole basin mixer*  
I-Loch-Bidetbatterie



**Ref. A52.49/3VM**

Inverseur 4 voies mural  
*Wall mounted diverter*  
Umstellventil





**Ref. A04.912**  
Manette métal lisse  
Smooth metal lever handle  
Glatter Metallhebelgriff



**Ref. A04.112BG**  
Mélangeur bain-douche 4 trous  
Rim mounted 4-hole bath-shower mixer  
4-Loch-Wannenfüll-und Brausebatterie



**Ref. A04.913**  
Manette métal torsadée  
Twisted metal lever handles  
Metallhebelgriff – Kordel



# Broadway

design 

à manettes



**Ref. A04.151**  
Mélangeur de lavabo 3 trous  
*Rim mounted 3-hole basin mixer*  
3-Loch-Waschtischbatterie



264 TRADITIONNELLE

Ref. G08.151  
Mélangeur de lavabo 3 trous  
Rim mounted 3-hole basin mixer  
3-Loch-Waschtischbatterie

# Pompadour



**Ref. G08.113BG**

Mitigeur de bain-douche 3 trous sur gorge  
*Rim mounted 3-hole bath-shower mixer*  
3-Loch-Wannenfüll- und Brausebatterie



**Ref. G08.2647**

Ensemble thermostatique de douche  
avec pomme de douche Ø 200 mm  
*Wall mounted shower thermostat set  
with shower head Ø 200 mm / 8"*  
Thermostat-Duschbatterie  
mit Brausekopf Ø 200 mm



**Ref. G08.2155**

Mélangeur de lavabo monotrou  
*Rim mounted one hole basin mixer*  
1-Loch-Zweigriff-Waschtischbatterie

**Ref. G08.13B**

Mélangeur bain-douche mural  
*Wall mounted bath mixer and shower set*  
Wannenwandbatterie



**Ref. G08.175/C - 175/H**

Robinet de lavabo  
*Rim mounted pillar tap*  
1-Loch-Standventil



# BAROQUE



Malmaison . 268

Amour de Trianon . 274

Cygne . 276

Versailles . 278

Tête de lion . 280



# Malmaison Métal

design  
  
CREATIONS  
Jean-Charles MATHISSE  
PARIS





# Malmaison

design   
CREATIONS  
Jean-Claude GOLZING  
PARIS

## Métal - Cristal



**Ref. U94.151**

Mélangeur de lavabo 3 trous - Cristal  
Rim mounted 3-hole basin mixer - Crystal  
3-Loch-Waschtischbatterie - Kristall



**Ref. U93.151**

Mélangeur de lavabo 3 trous  
Rim mounted 3-hole basin mixer  
3-Loch-Waschtischbatterie



**Ref. U93.112BG**

Mélangeur bain-douche 4 trous  
4-hole bath shower mixer  
4-Loch-Wannenfüll- und Brausebatterie

**Ref. U93.514**

Porte-serviette  
Single towel rail  
Handtuchstange





**Ref. U93.84L + 286P + 5400B + 54**  
Ensemble de douche thermostatique  
*Thermostatic shower set*  
Thermostat Duschebatterie



272 BAROQUE

Christofle  
PARIS

# Malmaison

## Bianca carrara - Portoro

design  
  
CREATIONS  
Jean-Claude DELZENNE  
PARIS



**Ref. U95.41G**

Mélangeur de bain 3 trous mural - Portoro  
Wall mounted 3-hole bath mixer - Portoro  
3-Loch-Wannenfüllbatterie zur Wandmontage - Portoro



**Ref. U95.151**

Mélangeur de lavabo 3 trous - Portoro  
Rim mounted 3-hole bath mixer - Portoro  
3-Loch-Waschtischbatterie - Portoro

**Ref. U96.151**

Mélangeur de lavabo 3 trous - Bianca carrara / Rim mounted 3-hole basin mixer - Bianca carrara  
3-Loch-Waschtischbatterie - Bianca Carrara

# Amour de Trianon



**Ref. G24.40N**  
Mélangeur de lavabo 3 trous mural  
Wall mounted basin set  
3-Loch-Waschtischbatterie zur Wandmontage



**Ref. G24.538AC**  
Porte-papier rouleau  
Wall mounted WC paper holder  
WC-Papierhalter



**Ref. G24.510A**  
Porte-peignoir double  
Double robe hook  
Doppelter Bademantelhaken



**Ref. G24.112B**  
Mélangeur bain-douche 4 trous sur gorge  
Rim mounted 4-hole bath-shower mixer  
4-Loch-Wannenfüll-und Brausebatterie



**Ref. G24.504N**  
Anneau porte-serviette  
Single towel ring  
Handtuchring



**Ref. G24.514**  
Porte-serviette  
Single towel rail  
Handtuchstange



**MEN**

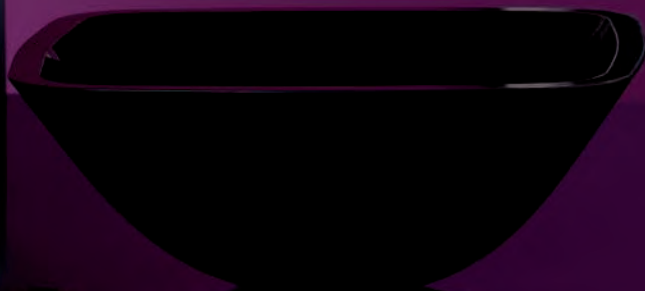

276 BAROQUE

# Cygne



**Ref. G31.112BSG**

Mélangeur bain-douche 4 trous sur gorge  
Rim mounted 4-hole bath-shower mixer  
4-Loch-Wannenfüll- und Brausebatterie



**Ref. G31.538AC**

Porte-papier rouleau  
Wall mounted WC paper holder  
WC-Papierhalter



**Ref. G31.504N**

Anneau porte-serviette  
Single towel ring  
Handtuchring



**Ref. G31.4720**

Ensemble pot à balai mural  
Wall mounted WC brush set  
WC-Bürstentopf-garnitur

**Ref. G31.29SGI**

Bec de bain sur gorge à inversion  
Rim mounted bath spout with diverter  
Wanneneinlauf zur Standmontage mit Umstellung



# Versailles



**Ref. G14.112BG**  
Mélangeur bain-douche 4 trous sur gorge  
Rim mounted 4-hole bath-shower mixer  
4-Loch-Wannenfüll- und Brausebatterie

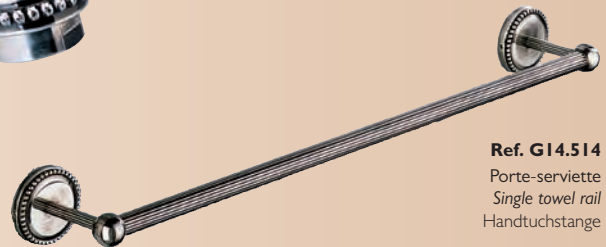

**Ref. G14.514**  
Porte-serviette  
Single towel rail  
Handtuchstange



**Ref. G14.504N - 508**  
Anneau porte-serviette - Porte-peignoir  
Single towel ring - Single robe hook  
Handtuchring - Bademantelhaken



**Ref. G14.41G**  
Mélangeur de bain 3 trous mural  
Wall mounted 3-hole bath mixer  
3-Loch-Wannenfüllbatterie zur Wandmontage





# Tête de lion



**Ref. G99.22F**

Tête de lion petit modèle  
Wall mounted lion's head (small size)  
Löwenkopf zur Wandmontage, kleines Modell



**Ref. G99.22GM**

Tête de lion romain  
Wall mounted lion's head (medium size)  
Löwenkopf zur Wandmontage, mittelgroßes Modell

280

BAROQUE



**Ref. G99.22TLA**

Tête de lion assyrien

Wall mounted lion's head (large size)

Löwenkopf zur Wandmontage, großes Modell





# CASCADE

Perle .	284
Le 11 by Alberto Pinto .	288
Niagara .	290
Urban .	292
Ellipse .	294



284 CASCADE

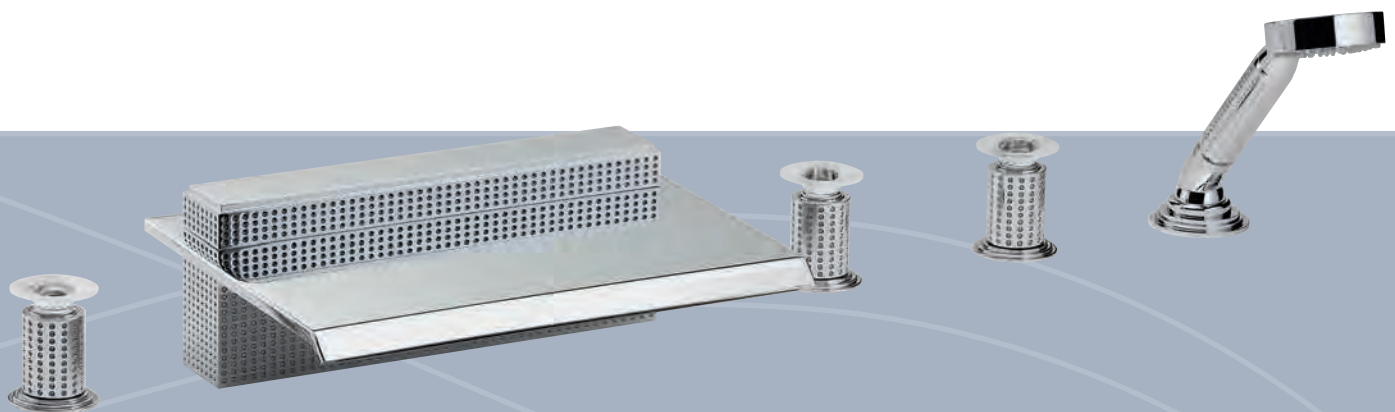

**Ref. A2i.1132-A**

Mélangeur de bain avec douchette alimentée par mitigeur progressif  
 Rim mounted bath mixer + handshower set with single lever mixer  
 with progressive cartridge, waterfall spout  
 Wannenbatterie mit 1-Loch-Einhandmischer mit Brausegarnitur  
 und progressiver Kartusche, Wasserfallauslauf



**Ref. A2i.151BP**

Mélangeur de lavabo 3 trous, bec cascade  
 Rim mounted 3-hole basin mixer, waterfall spout  
 3-Loch-Waschtischbatterie, Wasserfallauslauf

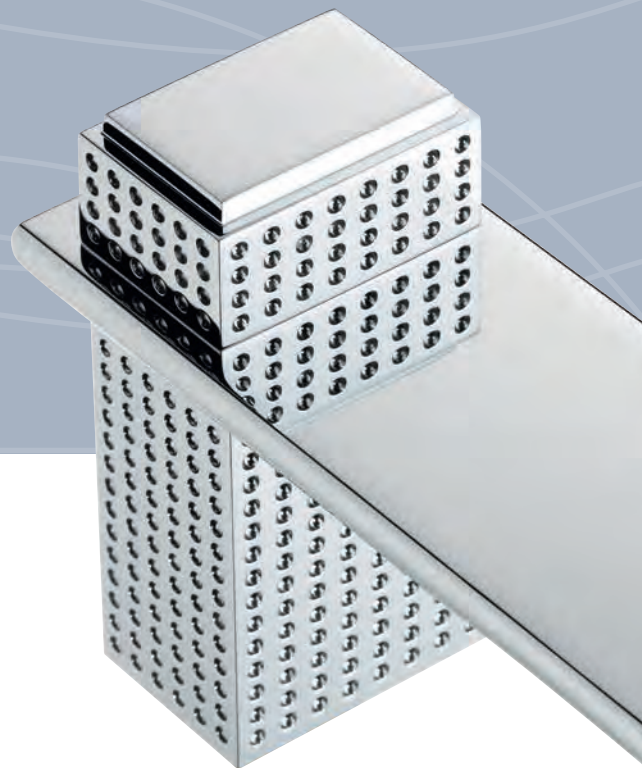



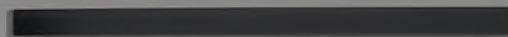
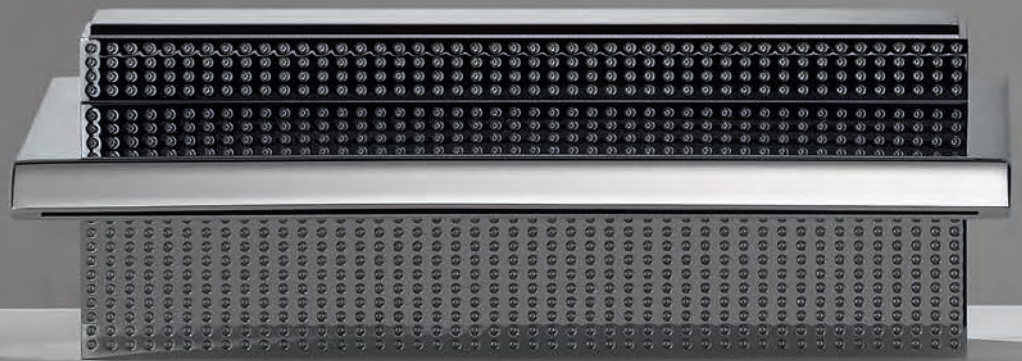

286 CASCADE

Design Pierre-Yves ROCHON - LALIQUE



# Le II by Alberto Pinto

by   
CREATIONS  
Jean-Claude BIZZIENNE  
PARIS



**Ref. U2A.1132-A**

Mélangeur de bain avec douchette alimentée par mitigeur progressif

Rim mounted bath mixer + handshower set with single lever mixer with progressive cartridge, waterfall spout

Wannenbatterie mit 1-Loch-Einhandmischer mit Brausegarnitur und progressiver Kartusche, Wasserfallauslauf



**Ref. U2A.22NIA/A**

Bec de bain mural 200 mm

Wall mounted waterfall bath spout 200 mm / 8"

Wasserfall-Wannenauslauf zur Wandmontage 200 mm

**Ref. U2A.29NIA/A**

Bec de bain sur gorge 166 mm

Rim mounted waterfall bath spout 166 mm / 6 1/2"

Wasserfall-Wannenauslauf zur Standmontage 166 mm



Design Alberto Pinto

CASCADE 289



**Ref. A38.29NIA/D**

Bec de bain sur gorge 400 mm

Rim mounted waterfall bath spout 400 mm / 16"

Wasserfall-Wannenauslauf zur Standmontage 400 mm

**290** CASCADE

# Niagara

design  
  
CREATIONS  
Joux-Clément SERRIERE  
PARIS



**Ref. A38.6500P**

Mitigeur de lavabo monotrou  
Single lever basin mixer  
Waschtisch-Einhebelmischer



**Ref. A38.22NIA/A**

Bec de bain mural 230 mm  
Wall mounted waterfall bath spout 230 mm / 9"  
Wasserfall-Wannenauslauf zur Wandmontage 230 mm



**Ref. A38.151**

Mélangeur de lavabo 3 trous  
Rim mounted 3-hole basin mixer  
3-Loch-Waschtischbatterie

# Urban

design   
CREATIONS  
Jean-Claude DELPINE  
PARIS



**Ref. A39.29NIA/E**

Bec de bain sur gorge 350 mm

Rim mounted waterfall bath spout 350 mm / 14"

Wasserfall-Wannenauslauf zur Standmontage 350 mm



**Ref. A39.22NIA/E**

Bec de bain mural 350 mm

Wall mounted waterfall bath spout 350 mm / 14"

Wasserfall-Wannenauslauf zur Wandmontage 350 mm

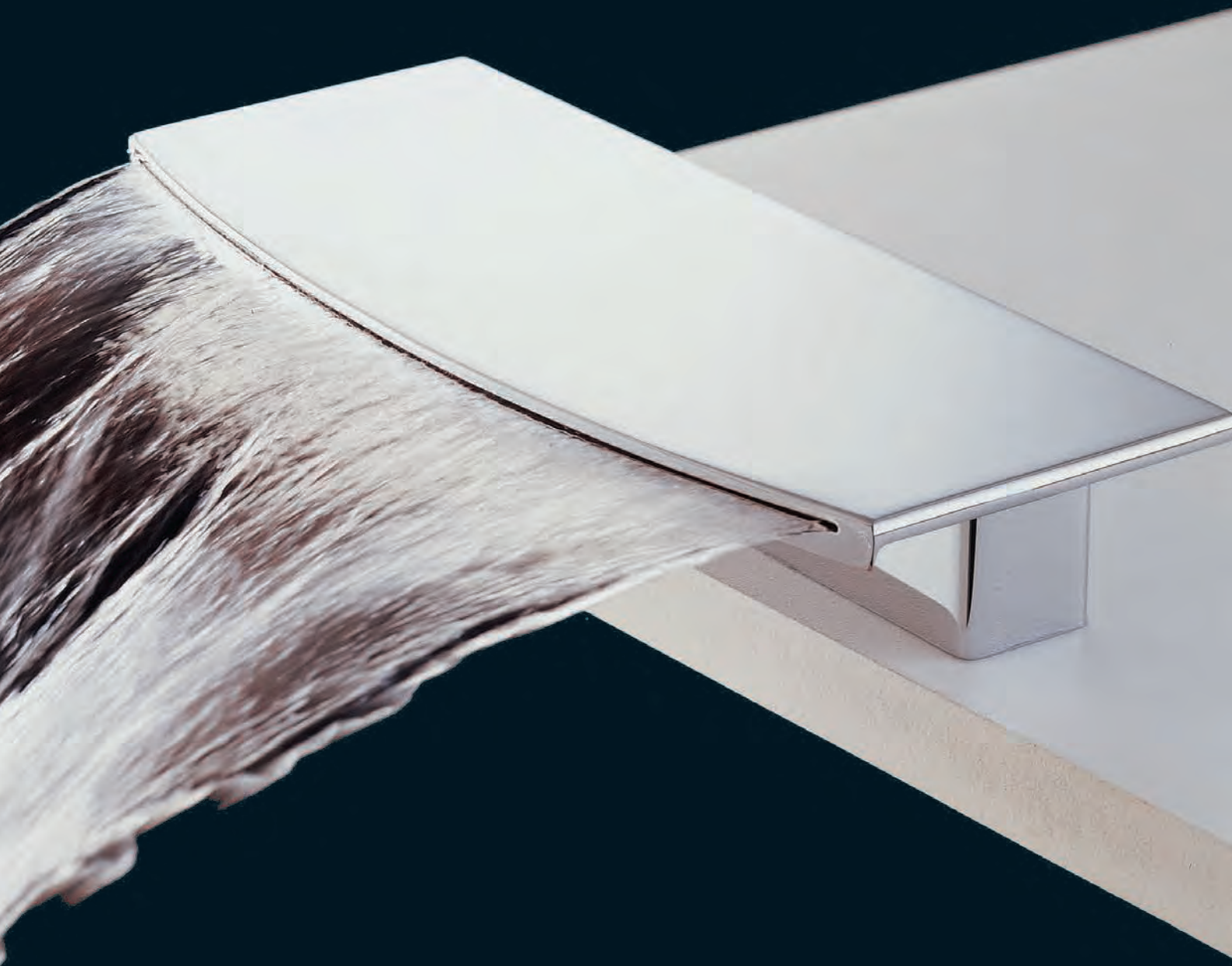

CASCADE 293





# Ellipse

design  
  
CREATIONS  
Jean-Claude DELAPLANE  
PARIS



**Ref. A44.170F + UID.35 x2**

Mélangeur de lavabo 3 trous  
Rim mounted 3-hole basin mixer  
3-Loch-Waschtischbatterie

**Ref. A44.29NIA/D**

Bec de bain sur gorge 400 mm  
Rim mounted waterfall bath spout 400 mm / 16"  
Wasserfall-Wannenauslauf zur Standmontage 400 mm

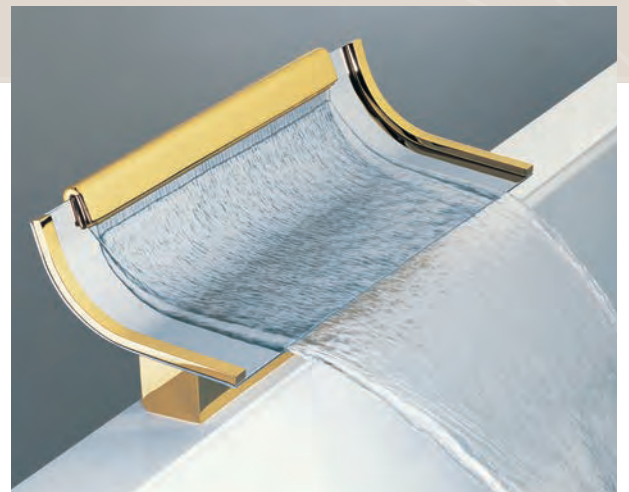

CASCADE 295



# SKY SHOWERS HYDROMASSAGE



Sky showers . 298  
Hydromassage . 300

# Sky showers

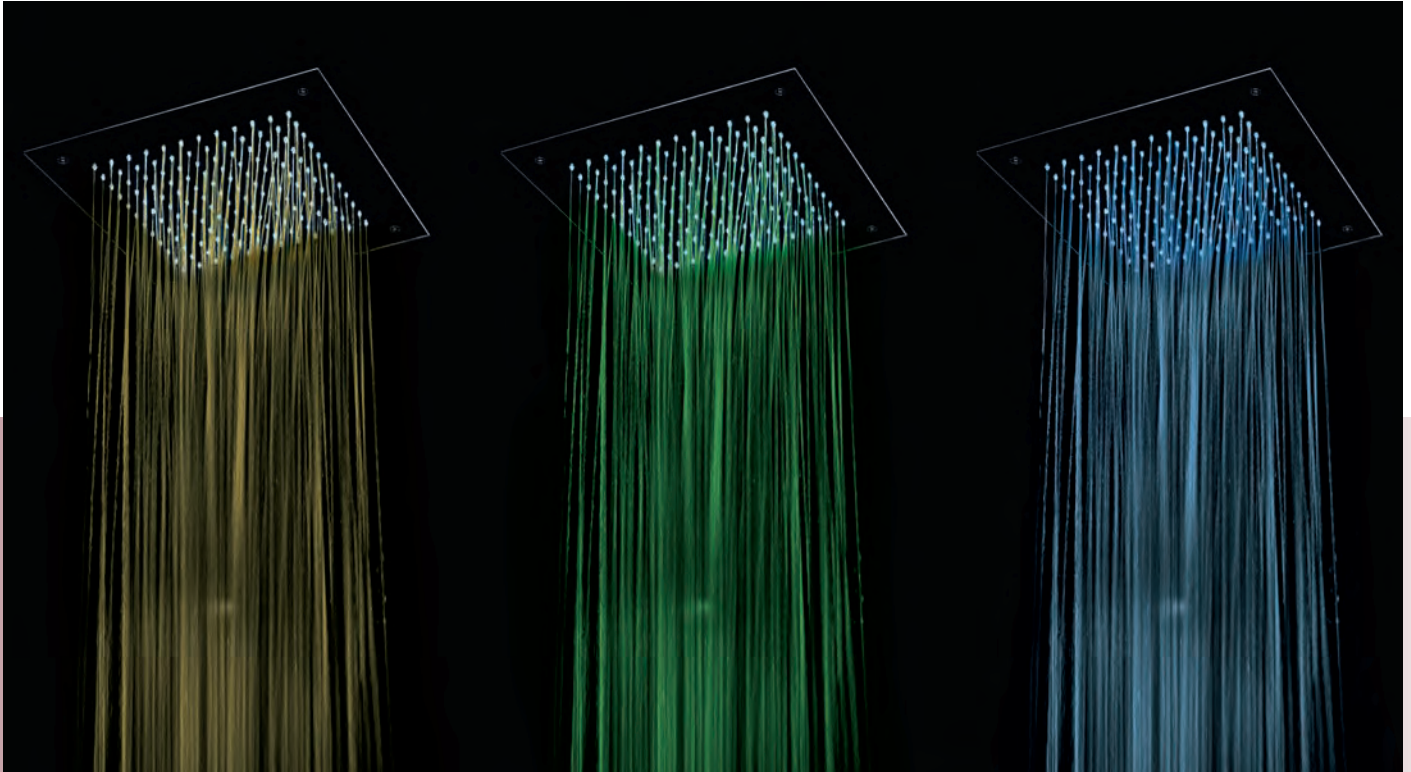

**Ref. G00.491**

Plafond de douche inox anti-calcaire chromothérapie 380 x 380 mm  
 Stainless steel anti-scale sky shower chromotherapy 380x380 mm (15"x15")

Duschkopf auf Edelstahl mit Chromotherapie 380 x 380 mm mit antikalksystem

Disponible aussi sans chromothérapie / Also available without chromotherapy / Verfügbar auch ohne Chromotherapie **Ref. G00.493**

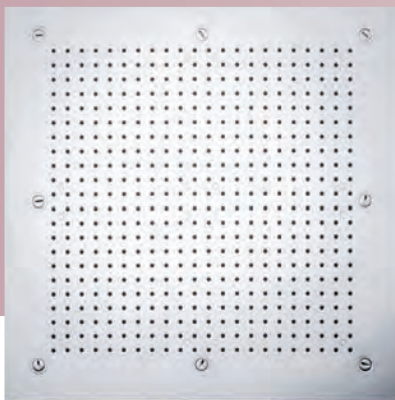

**Ref. G00.487**

Plafond de douche anti-calcaire 445 x 445 mm  
 Metal sky shower, anti-scale  
 445x445 mm (17 1/2" x 17 1/2")

Duschkopf „Sky Shower“ 445 x 445 mm  
 mit Antikalksystem

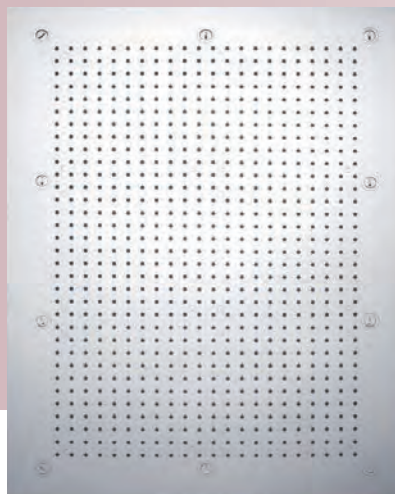

**Ref. G00.488**

Plafond de douche anti-calcaire 445 x 620 mm  
 Metal sky shower, anti-scale  
 445x620 mm (17 1/2" x 24 3/8")

Duschkopf „Sky Shower“ 445 x 620 mm  
 mit Antikalksystem

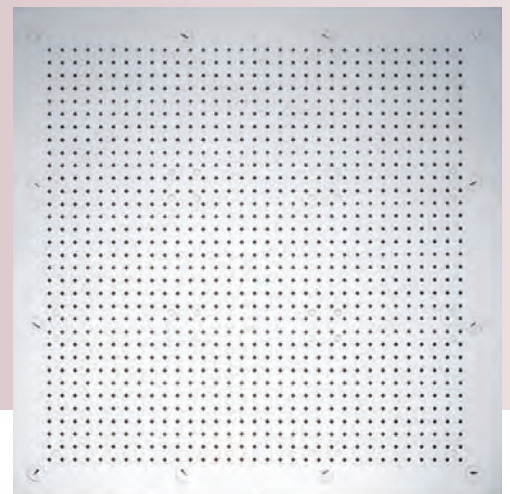

**Ref. G00.489**

Plafond de douche anti-calcaire 620 x 620 mm  
 Metal sky shower, anti-scale  
 620x620 mm (24 3/8" x 24 3/8")

Duschkopf „Sky Shower“ 620 x 620 mm  
 mit Antikalksystem

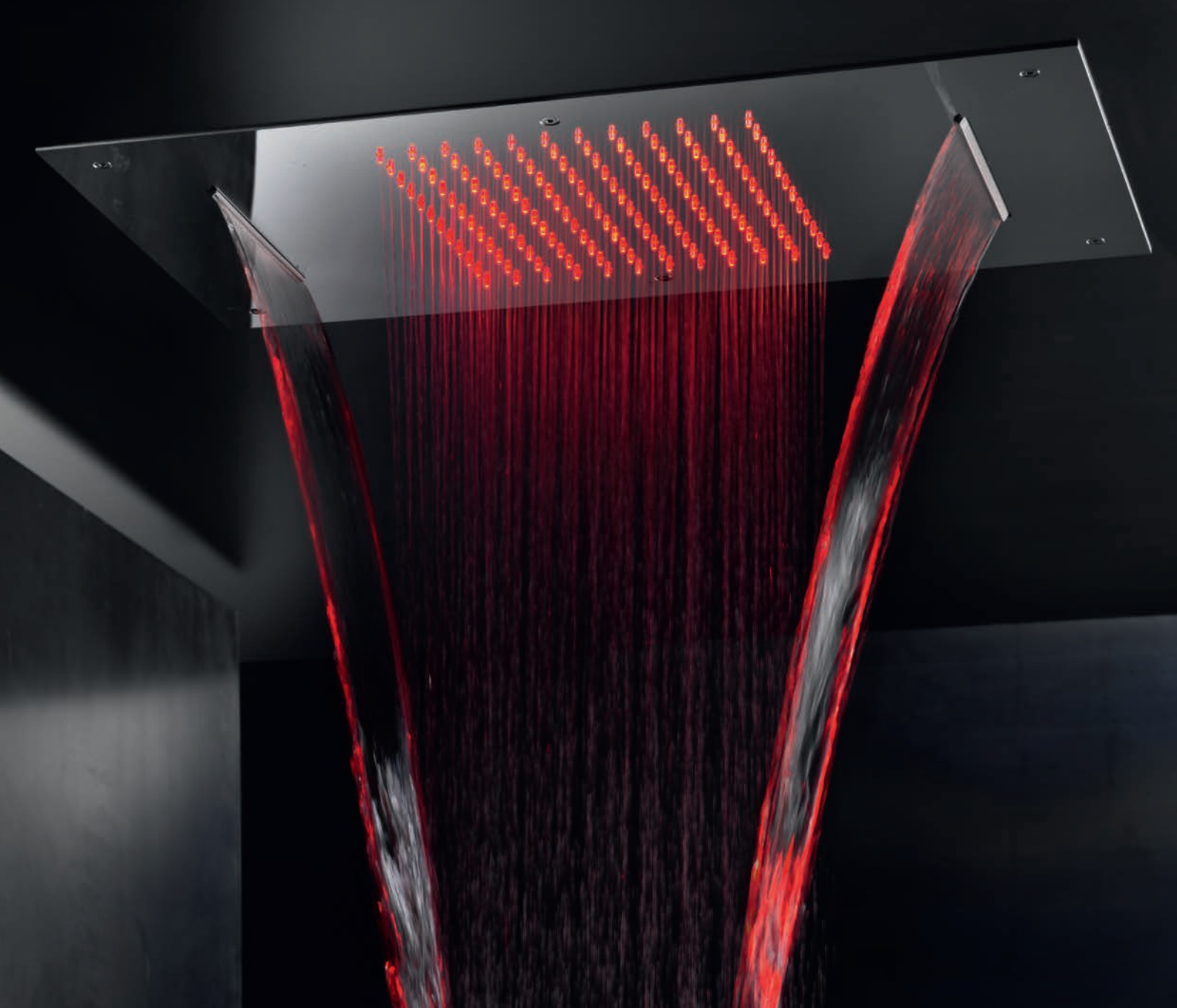

**Ref. G00.492**

Plafond de douche inox anti-calcaire chromothérapie avec lames d'eau 700 x 380 mm  
Stainless steel anti-scale sky shower chromotherapy with water blade 700x380 mm (27½"x15")  
Duschkopf auf Edelstahl mit chromotherapie mit Wasserschwalm 700 x 380 mm mit antikalksystem

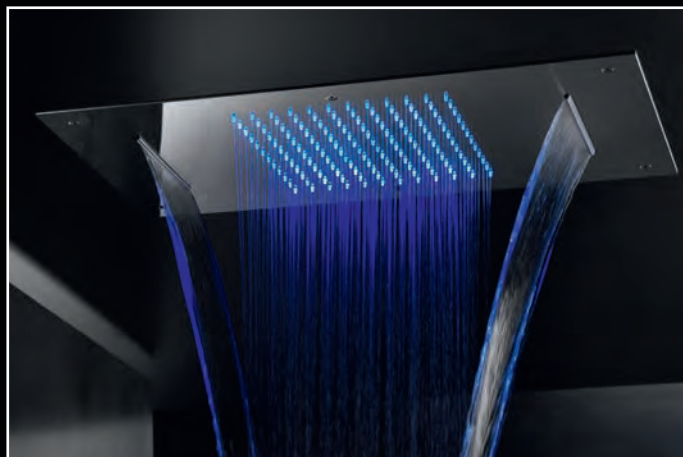

# Hydromassage



**Ref. G00.280C + Ref. 82V**

Pomme anti-calcaire 300 x 300 mm + bras 110 mm  
*Anti-scale showerhead 300x300 mm (12"x12") + shower arm 110 mm (4 1/2")*  
 Brausekopf 300 x 300 mm mit Antikalksystem und Brausearm 110 mm



**Ref. G00.281C + Ref. 84L**

Pomme anti-calcaire 200 x 200 mm + bras 450 mm  
*Anti-scale showerhead 200x200 mm (8"x8") + showerarm 450 mm (17 3/4")*  
 Brausekopf 200 x 200 mm mit Antikalksystem und Brausearm 450 mm



**Ref. G00.280EP + Ref. 82V**

Pomme anti-calcaire Ø 300 mm + bras 110 mm  
*Anti-scale showerhead Ø300 mm (12") + shower arm 110 mm (4 1/2")*  
 Brausekopf Ø 300 mm mit Antikalksystem und Brausearm 110 mm



**Ref. G00.284EP + Ref. 84L**

Pomme anti-calcaire Ø 400 mm + bras 450 mm  
*Anti-scale showerhead Ø 400 mm (16") + showerarm 450 mm (17 3/4")*  
 Brausekopf Ø 400 mm mit Antikalksystem und Brausearm 450 mm



**Ref. G00.288L**

Pomme anti-calcaire Ø 70 mm avec réglage du débit  
*Adjustable showerhead, anti-scale Ø 70 mm (2 3/4")*  
 Brausekopf mit Antikalksystem Ø 70 mm - Nadelstrahl hart/weich



**Ref. G00.280**

Pomme Ø 300 mm et bras 1"  
*Shower head Ø 300 mm (11 3/4") and arm 1"*  
 Stachelbrausekopf mit Brausearm 1" Ø 300 mm



**Ref. G00.910PR**

Pomme Ø 260 mm anti-calcaire et bras 1"  
*Anti-scale showerhead Ø 260 mm (10 1/4") and 1" arm*  
 Stachelbrausekopf mit Brausearm 1" Ø 260 mm mit Antikalksystem



**Ref. G00.281R**

Pomme rétro anti-calcaire Ø 220 mm  
*Anti-scale showerhead Ø 220 mm (8 5/8")*  
 Brausekopf Ø 220 mm mit Antikalksystem



**Ref. G00.490**

Pomme inox murale anti-calcaire 535 x 160 mm  
*Wall mounted Stainless steel anti-scale showerhead 535x160 mm (21"x6")*  
 Brausekopf auf Edelstahl mit antikalksystem

# Hydromassage



**Ref. G00.3640**  
Douchette sportive ¾"  
Sport shower head ¾"  
Schwallbrause ¾"

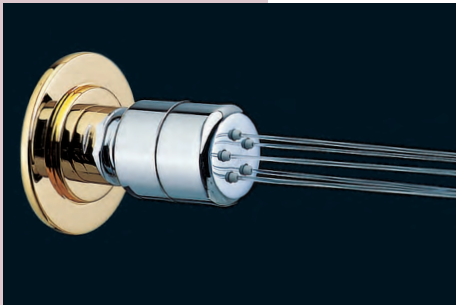

**Ref. G00.290/B**  
Jet de massage anti-calcaire  
Anti-scale body jet  
Seitenbrause mit Antikalksystem



**Ref. G00.900**  
Rampe de douche anti-calcaire  
Anti-scale rainbar  
Seiten-Regendusche mit Antikalksystem



**Ref. G00.67**  
Douchette Turbojet  
Turbojet handshower  
Turbojet Handbrause

**Ref. G00.688**  
Pomme à galerie Ø 120 mm  
Gallery shower head Ø 120 mm / 4 ¾"  
Blechbrausekopf Ø 120 mm



**Ref. G00.286**  
Pomme de douche Ø 200 mm  
Shower head Ø 200 mm (8")  
Stachelbrausekopf Ø 200 mm



**Ref. G00.286P**  
Pomme de douche Ø 200 mm anti-calcaire  
Anti-scale shower head Ø 200 mm (8")  
Stachelbrausekopf Ø 200 mm mit Antikalksystem



**Ref. G00.281EP**  
Pomme de douche Ø 200 mm anti-calcaire  
Anti-scale shower head Ø 200 mm (8")  
Stachelbrausekopf Ø 200 mm mit Antikalksystem





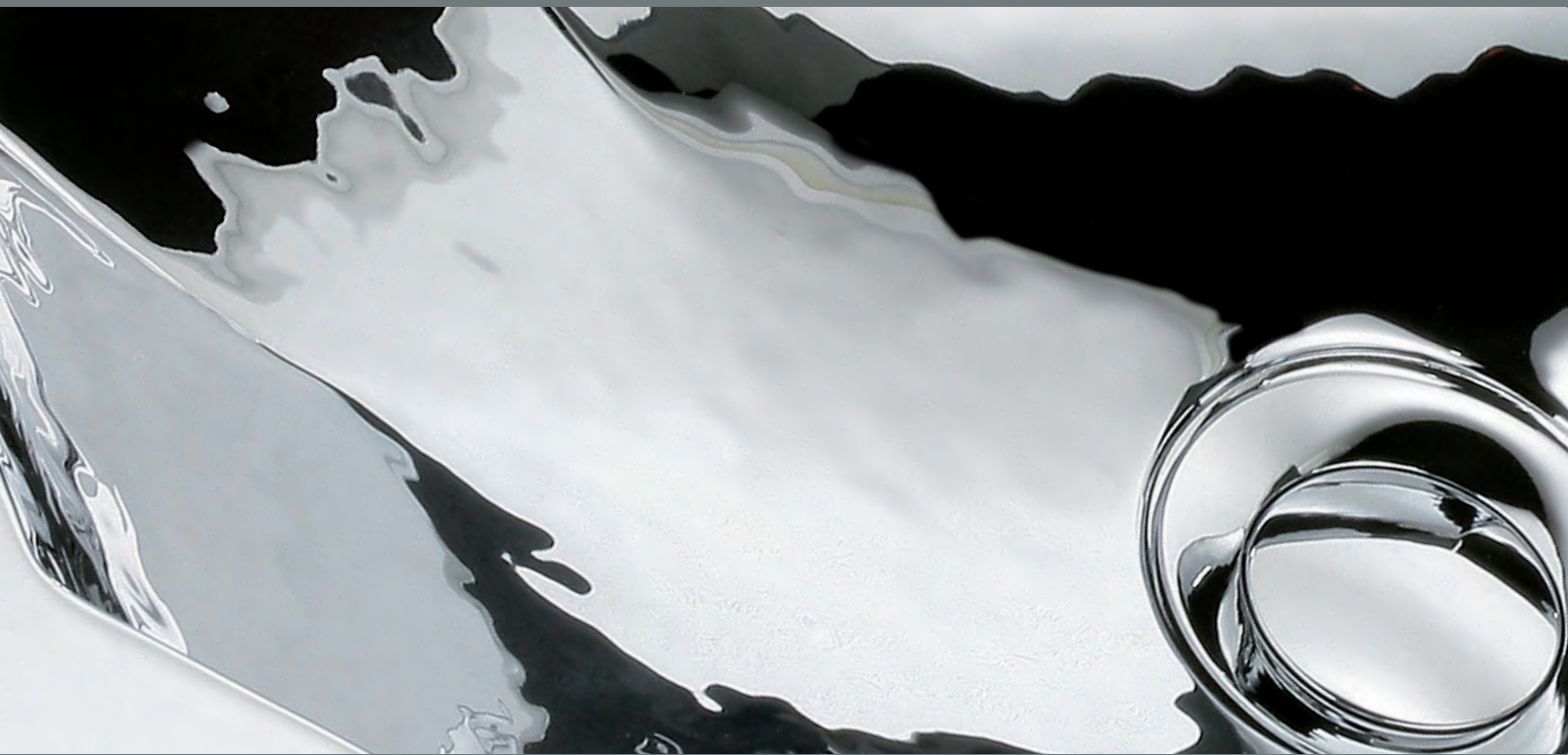

# VASQUES MÉTAL



Vasques métal . 304  
*Metal basins* . 304  
Metallwaschbecken . 304

# Vasques métal

Metal basins / Metallwaschbecken

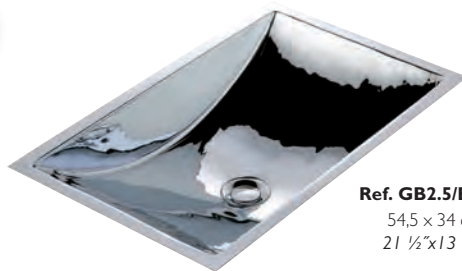

**Ref. GB2.5/BP**  
54,5 x 34 cm  
21 1/2" x 13 1/2"

**Ref. GB2.7/BP**  
54 x 38,5 cm  
21 1/4" x 15 1/4"

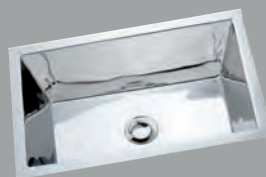

**Ref. GB2.6/BP**  
47 x 32,5 cm  
18 1/2" x 12 3/4"

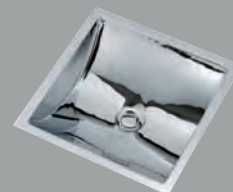

**Ref. GB2.10/BP**  
37 x 37 cm  
14 1/2" x 14 1/2"

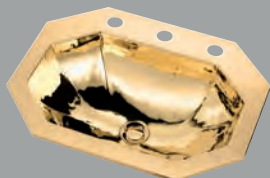

**Ref. GB2.4/3**  
53 x 42 cm  
20 3/4" x 16 1/2"

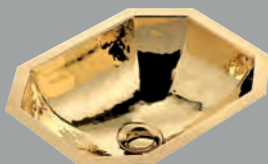

**Ref. GB2.44/BP**  
36 x 28 cm  
14 1/4" x 11"



**Ref. GB2.1/1**  
Ø 48 cm  
Ø 19"



**Ref. GB2.2/BP**  
49 x 36 cm  
19 1/2" x 14 1/2"

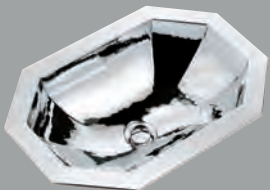

**Ref. GB2.4/BT**  
53 x 37 cm  
20 3/4" x 14 1/2"



**Ref. GB2.1/BP**  
Ø 39 cm  
Ø 15 1/4"

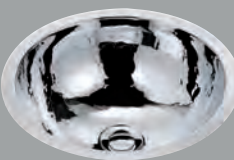

**Ref. GB2.11/BP**  
Ø 35 cm  
Ø 13 3/4"



**Ref. GB2.2/3**  
60 x 45 cm  
23 1/2" x 17 3/4"



**Ref. GB2.8/AP**  
Ø 41 cm - H 12 cm  
Ø 16 1/4" - H 4 3/4"

304 VASQUES MÉTAL





# Accessoires

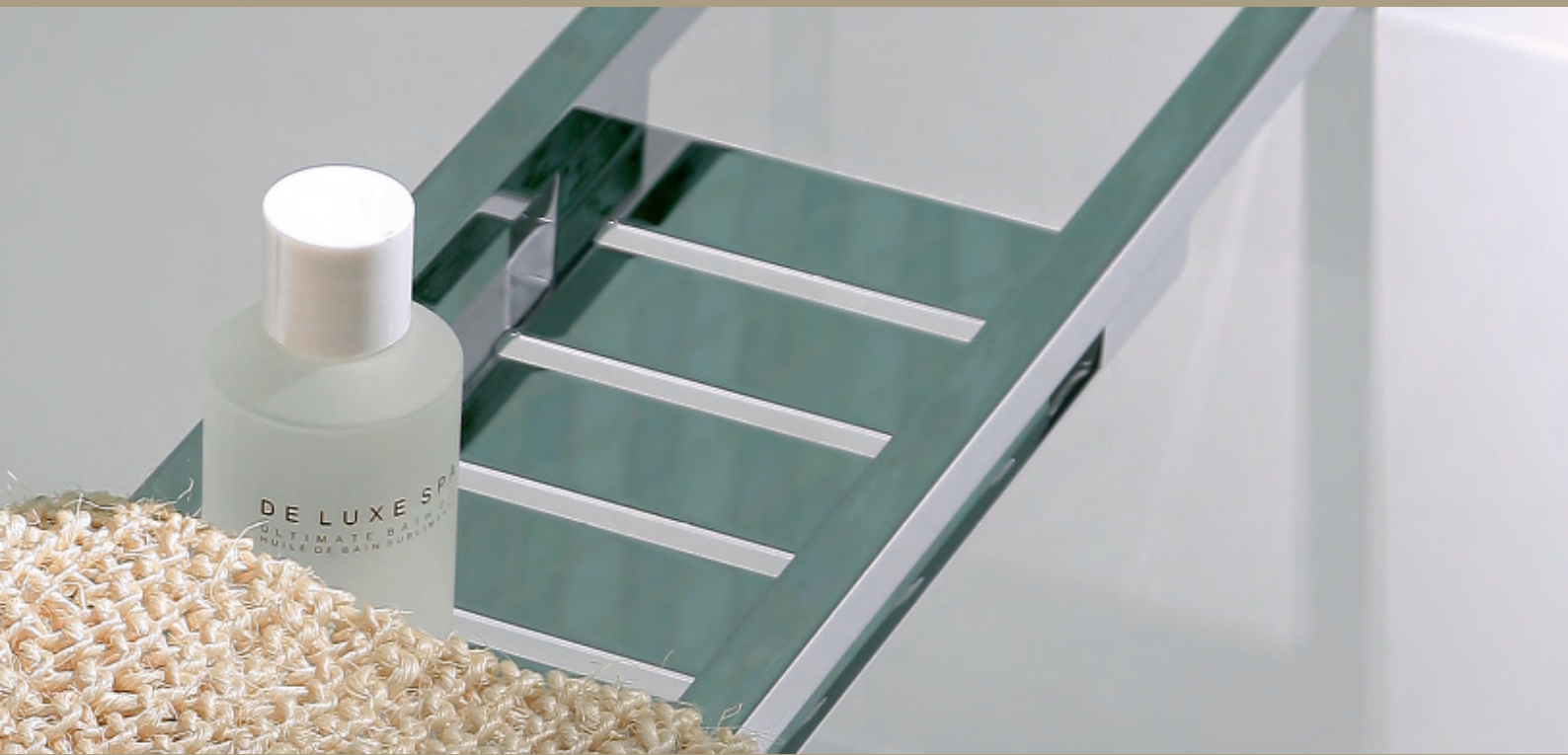

Accessoires . 308

*Accessories* . 308

Accessoires . 308

# Accessoires

Accessories / Accessoires



**Ref. G00.623**

Pont de baignoire 950 x 150 mm  
Bath rack 950x150 mm / 37 1/2"x6"  
Badewannenablage 950 x 150 mm



**Ref. G00.2704**

Boîte à mouchoirs à poser petit modèle  
Tissue box small size  
Taschentuchbox aus Messing zum Aufstellen,  
kleines Modell



**Ref. G00.704**

Boîte à mouchoirs à poser grand modèle  
Tissue box large size  
Taschentuchbox aus Messing zum Aufstellen, großes Modell



**Ref. G00.3626**

Porte-savon fil mural d'angle  
Large net corner soap dish  
Seifenkorb zum Eckenbau

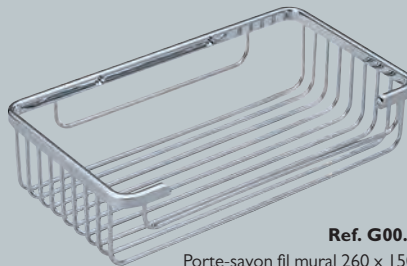

**Ref. G00.2626**

Porte-savon fil mural 260 x 150 mm  
Net soap dish 260x150 mm / 10 1/4"x6"  
Wandseifenkorb 260 x 150 mm



**Ref. G00.4600**

Porte-revues  
Magazine rack  
Zeitungsständer



**Ref. G00.667**

Miroir mural  
Wall mounted mirror  
Wandspiegel



**Ref. G00.10C**

Porte-serviettes sur pieds  
Towel stand  
Handtuchständer



**Ref. G00.666**

Miroir à poser  
Free standing mirror  
Standspiegel

TOUS STYLES 309





310 TOUS STYLES

Ref. G00.660

Miroir double face à poser  
Free standing mirror 2 faces

Zweiseitiger Standkosmetikspiegel

# Accessoires

Accessories / Accessoires



**Ref. G00.4RACK2**

Porte-serviettes 650 x 350 mm  
Towel rail and stack 650x350 mm / 25 1/2" x 13 3/4"  
Ablage 650 x 350 mm

**Ref. G00.527SGM**

Barre de relèvement grand modèle  
Bath hand grip large size  
Wannengriff, großes Modell



**Ref. G00.527S**

Barre de relèvement  
Bath hand grip  
Wannengriff



**Ref. G00.622**

Pont de baignoire réglable  
Adjustable bath rack  
Verstellbare Badewannenablage



**Ref. G00.612**

Distributeur de savon liquide  
Dispenser of liquid soap  
Seifenspender



**Ref. G00.661**

Miroir mural double face  
Wall mounted mirror 2 faces  
Zweiseitiger Wandspiegel



**Ref. G00.713CL**

Corbeille à pédale  
Waste bin with lid and pedal  
Kosmetiktreimer

TOUS STYLES 311

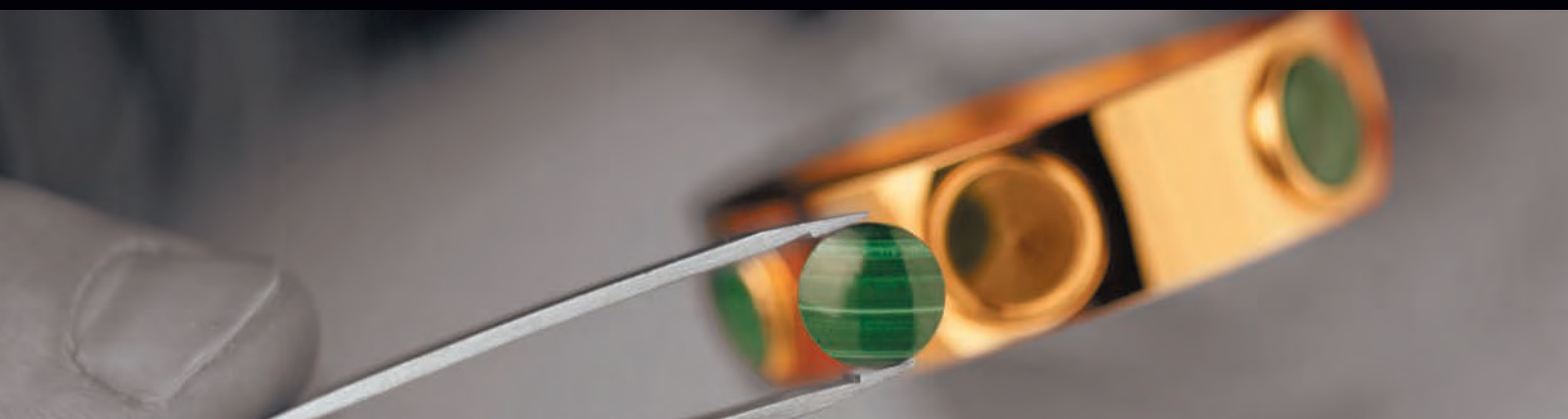



“THG démontre en permanence  
ses capacités d’adaptation et ses  
possibilités de développement  
de produits spécifiques”  
N’hésitez pas à nous consulter..

*THG offers a wide range of models.  
However, if you have specific requests  
or needs we are able to answer them.  
Don't hesitate to ask us...*

THG bietet eine breite Auswahl an  
verschiedenen Modellen. Wenn Sie jedoch  
besondere Wünsche oder Vorstellungen  
haben, können wir selbstverständlich auch  
diesen gerecht werden. Wir stehen Ihnen  
jederzeit gerne zur Verfügung.

# Un savoir-faire unique

## A unique Know-How

### Einzigartiges Know-How



L'entreprise maîtrise tous les corps de métier, tous les savoir-faire qui interviennent dans la fabrication d'une robinetterie, d'un accessoire. La meilleure démonstration serait d'avoir un produit THG entre les mains. Finition, assemblage et générosité des matières parlent d'eux-mêmes. Tout concourt à vous faire comprendre que vous êtes en présence d'un produit d'exception, qui le restera au fil du temps.

La qualité des produits THG est le résultat de toute la politique de l'entreprise, dont voici les points essentiels :

- Plus de 10 métiers intégrés. Bureau d'études, outillage, fonderie, usinage, polissage, traitement de surface (respect de l'environnement : aucun rejet), assemblage...
- Compétence individuelle des hommes associée à la haute technologie (robots polisseurs, tours numériques...)
- Une grande largeur de gamme
- Savoir-faire reconnu dans le monde entier.

*The company is master of all trades, with all of the know-how involved in the manufacture of a valve or tap or accessory. The best demonstration would be to hold a THG product in one's hand. Finish, assembly and generosity of raw materials all speak for themselves. Everything conspires to make you believe that you are in the presence of an exceptional product, and one that will remain so through the years.*

*The quality of THG products is the result of every aspect of THG company policy, the essential points of which are as follows:*

- *More than 10 trades incorporated into the product. Design, Research & Development, tooling, foundry, machining, polishing, plating (environment friendly: no refusal), assembly...*
- *The alliance of a craft know-how with modern equipment (polishing robots, N.C. drilling and threading machines...)*
- *Unequaled depth of range of elegant bathroom fittings.*
- *THG's know-how is recognised throughout the world.*

Das Unternehmen besitzt ein umfassendes Fachwissen in allen Fertigungsbereichen und das zur Herstellung von Armaturen und Zubehör erforderliche technische Know-how. Die Qualität ließe sich am einfachsten erklären, wenn Sie ein THG-Produkt in den eigenen Händen hielten. Oberflächenbearbeitung, Montage und Material sprechen für sich. Sie sehen und fühlen sofort, dass Sie ein außergewöhnlich-hochwertiges Produkt vor sich haben, das jahrelang einwandfrei funktionieren wird.

Diese Qualität aller THG Produkte ist das Ergebnis der gesamten Unternehmenspolitik von THG, die sich in folgenden Punkten zusammenfassen lässt:

- Mehr als 10 Berufe in der Herstellung, Gießerei, Bearbeitung, Polierung, Oberflächenbehandlung (schadstofflos und somit umweltfreundlich), Montage, im Planungsbüro und Werkzeugbau...
- Fachkompetenz aller Mitarbeiter/-innen im Umgang mit den hochtechnisierten Produktionsanlagen (wie z.B. Polierroboter, NC-Drehmaschinen...).
- Unübertroffen breite Produktpalette.
- Weltweit anerkanntes Know-how.

# Étapes de fabrication

## Manufacturing process

### Die Fertigungsstufen



#### Design et bureau d'études

Conception des assemblages et outillages et réalisation des dessins techniques.

#### Outillage

Notre robinetterie et nos accessoires sont fabriqués à partir de lingots de laiton à 100%.

#### Fonderie

Le laiton en fusion est fondu à environ 900°C. La variété des équipements tant en noyautage qu'en moulage, rend possible la réalisation de pièces d'une grande variété.

#### Usinage

Équipée des centres numériques dernière génération, THG bénéficie du savoir-faire et des hommes sachant créer les produits répondant aux besoins de nos marchés.

#### Polissage

Chaque pièce de la robinetterie est soigneusement polie manuellement ou par robot.

#### Traitement de surface et vernissage

Tout en respectant les normes d'environnement les plus sévères, nous revêtons nos produits selon le desiderata de nos clients. La finition choisie est fixée par électrolyse sur la robinetterie et vernie pour les finitions cuivre et bronze.

#### Montage

Toutes les parties de la robinetterie sont assemblées par colle UV.

#### Expédition

Après contrôle final, les commandes clients sont emballées puis expédiées à travers le monde.

**Un contrôle rigoureux est effectué à chaque étape de production.**

#### Research, development and design Tooling

*All our fittings and accessories are made of 100% brass ingot.*

#### Foundry

*The brass is cast around 900°C. The variety of the equipment, both coring and moulding, makes possible the creation of a large variety.*

#### Machining

*THG is equipped with the latest generation of numerical-control centres, but has nevertheless retained the know-how and the people capable of creating products which can satisfy the very different needs of our market.*

#### Polishing

*Each part of the tap is carefully polished.*

#### Plating workshop

*While complying with the most constraining environmental standards, we finish our products according to the desires of our customers. The chosen finishing is settled by electrolysis on the tap (or by varnishing for lacquers).*

#### Assembly

*All the parts of the taps are UV-glued.*

#### Shipping

*After final inspection, the customer orders are packed and then shipped around the world by every conceivable means of transport.*

**A rigorous control is made at each step of the manufacturing.**

#### Design und Planungsbüro Werkzeug

Unsere Armaturen und Accessoires werden aus 100% reinem Messing gefertigt.

#### Giesserei

Die Messingschmelze wird bei einer Temperatur von ca. 900°C gegossen. Mit den zahlreichen Ausrüstungsteilen der Giesserei lassen sich Produkte im Kern- und Einformverfahren fertigen und damit Teile eines vielseitigen Programms erstellen.

#### Bearbeitung

THG produziert mit der neuesten Generation der NC-Bearbeitungsanlagen. Die Mitarbeiter/-innen besitzen ein entsprechend fachliches Know-how, so dass Produkte geschaffen werden, die den Anforderungen des Marktes voll entsprechen.

#### Polierung

Jedes einzelne Teil der Armaturen wird sorgfältig von Hand poliert oder mit einem Polierroboter bearbeitet.

#### Oberflächenbearbeitung

Die Oberflächenbearbeitung erfolgt unter Einsatz ausgesprochen umweltfreundlicher Verfahren nach den jeweiligen Kundenanforderungen. Die gewünschte Oberfläche oder Lackschicht wird elektrolytisch auf den Messingkörper aufgetragen.

#### Montage

Alle Bauteile einer Armatur werden im UV-Klebeverfahren zusammengebaut.

#### Versand

Nach der Endprüfung werden die Artikel kundenspezifisch verpackt und in alle Welt versandt.

**Nach jeder Fertigungsstufe Arbeitsschritt des Produktionsablaufs erfolgt eine strenge Prüfung.**

1. Assemblage / Assembly / Montage  
2. Contrôle qualité / Quality control / Qualitätskontrolle  
3. Exemple de produit final / End product / Endprodukt

# Normalisation

## Normalization / Normalisierung



La marque NF robinetterie sanitaire a été créée en 1966. Elle est synonyme de qualité et de confiance pour les consommateurs.

### Obtention de la marque NF

Le CSTB (organisme de contrôle) effectue des essais sur nos produits et contrôle l'efficacité de notre organisation qualité (inspections et audits). Il nous délivre ensuite le certificat NF correspondant.

Le CSTB effectue une surveillance régulière afin de vérifier, et ainsi de garantir à nos clients, la permanence de la conformité de nos produits et de notre organisation qualité aux exigences de la marque NF.

### Conformité du produit

La marque NF est garante de la conformité du produit aux :

- Caractéristiques dimensionnelles
- Caractéristiques acoustiques (< 30 db)
- Caractéristiques de débit
- Caractéristiques du revêtement.

### Qu'est-ce que l'ACS ?

L'ACS est une attestation de conformité sanitaire concernant les produits utilisés dans les installations fixes de production, de traitement et de distribution de l'eau destinée à la consommation humaine.

#### Qui cela concerne t-il ?

Tous les produits mis en vente sur le territoire français et qui entrent en contact avec l'eau doivent obtenir une attestation ACS.

Comme chez tous les grands fabricants européens nos produits ont la norme ACS, obligatoire depuis le 1<sup>er</sup> janvier 2007.

*The NF stamp on sanitary taps was created in 1966. It means quality and ensures confidence on the part of consumers.*

### Getting the NF stamp

*The CSTB (a control organization) carries out experiments on our products and checks our own quality tests to see how efficient they are (inspections and audits). Then, it gives us the NF certificate corresponding to the product in question. The CSTB regularly monitors our products in order to check their quality and tell our customers that these products always conform to the norm, that our controls meet the demands to get the NF stamp.*

### Certificate of compliance

*The NF stamp guarantees that the product complies with:*

- the regulated dimensions
- the regulated acoustic characteristics (less than 30 decibels)
- the regulated flow
- the regulated coating

### What does ACS mean?

*ACS is an attestation of sanitary conformity concerning the products used in fixed installations of production, treatment, distribution of the water that is to be consumed by men.*

#### Who does it concern?

*Our products, like all goods sold in mainland France and which come into contact with water, have the ACS standard, Certification of Sanitary Compliance.*

*The ACS has been a mandatory certification since 1 January 2007, which concerns goods used in fixed facilities for the production, treatment and distribution of water intended for human consumption.*

Das NF-Hygiene-gütesiegel für Armaturen wurde 1966 entwickelt. Für den Endverbraucher steht es für Qualität und Vertrauen.

### Erhalt des NF-Gütesiegels

Die Kontrollbehörde CSTB unterzieht unsere Produkte strengen Prüfungen und kontrolliert die Effizienz unserer Qualitätstests (Prüfungen und Audits). Daraufhin werden unsere Produkte mit dem NF-Gütesiegel ausgezeichnet. Durch diese regelmäßigen Prüfungen durch die CSTB können wir gegenüber unseren Kunden bestätigen, dass unsere Produkte und Qualitätstests stets den Kriterien für die Zertifizierung mit dem NF-Gütesiegel entsprechen.

### Prüfzeichen

Das NF-Gütesiegel garantiert, dass ein Produkt den folgenden Vorgaben entspricht:

- den Vorgaben an die Abmessungen
- den Vorgaben an die Akustik (< 30 dB)
- den Vorgaben an den Durchfluss
- den Vorgaben an die Beschichtung

### Wofür steht ACS?

Mit ACS wird bestätigt, dass die Produkte in festen Anlagen zur Herstellung, Handhabung und Wasserverteilung für den menschlichen Gebrauch den Hygienebestimmungen entsprechen.

#### Wen betrifft es?

Wie für alle mit Wasser in Berührung kommenden Produkte in Frankreich vorgeschrieben, haben auch unsere Artikel das ACS-Zertifikat (ACS = Attestation de Conformité Sanitaire). Das ACS-Zertifikat ist seit dem 01.01. 2007 für alle Produkte vorgeschrieben, die in festen, zur Gewinnung, Aufbereitung und Verteilung von Trinkwasser dienenden Anlagen verwendet werden.



# Environnement

## Environment / Umwelt

### Démarche environnementale

Depuis de nombreuses années THG s'est engagé dans une démarche environnementale active qui s'inscrit dans un processus de développement durable.

Tous nos investissements sont construits de façon à réduire notre impact sur l'environnement. Ceci se traduit par exemple par la mise en place d'un système de recyclage d'eau de nos installations de traitement de surfaces qui fonctionnent sans rejet d'eau. Nos nouveaux bâtiments mettent en œuvre des techniques innovantes de réduction d'énergie (conforme RT2005) voire de génération positive d'énergie avec la mise en place d'une installation photovoltaïque de plus de 1800 m<sup>2</sup>.

Une démarche permanente de réduction des déchets dans laquelle s'investissent nos salariés, nous permet de recycler la majorité de nos métaux, cartons, papiers et plastiques.



### Environmental Policy

*Years ago, THG initiated a process to actively protect our environment in a general pattern of sustained development. Our investments are aimed at reducing our impact on the environment.*

*This means, for example, that we have taken steps to recycle the water used to treat surfaces so that our system functions without rejecting water. Our new buildings include innovative technological processes to reduce energy (which is in accordance with RT2005). We actually produce energy with our photovoltaic installation (it covers more than 1,900 square yards).*

*We permanently try to reduce most of our waste with the help of our employees whose efforts enable us to recycle the greatest part of our metals, cardboard boxes, paper and plastics.*

### Unsere Umweltpolitik

Seit vielen Jahren setzt sich THG in einem Projekt für nachhaltige Entwicklung aktiv für den Umweltschutz ein.



Alle unsere Investitionen sind darauf ausgerichtet, die Auswirkungen unseres Betriebs auf die Umwelt zu verringern. So haben wir beispielsweise einen Aufbereitungsvorgang für das Wasser aus unseren Anlagen für Oberflächenbehandlungen entwickelt, der ohne Wasserabgabe funktioniert. In unseren neuen Betriebsstätten haben wir innovative technologische Prozesse zur Energieeinsparung installiert (gemäß RT2005). Darüber hinaus generieren wir mit unserer neu installierten Photovoltaikanlage von über 1.800 qm eigene Energie.

Unser Ziel, Abfall auf ein Minimum zu reduzieren, wird durch unsere Mitarbeiter unterstützt - so recyceln wir den Großteil unseres Metall-, Kartonagen-, Papier- und Kunststoffmülls.





Retrouvez THG sur Internet, Facebook, Twitter...

Visit THG's new website, Facebook, Twitter...

Finden Sie THG im Internet, Facebook, Twitter...

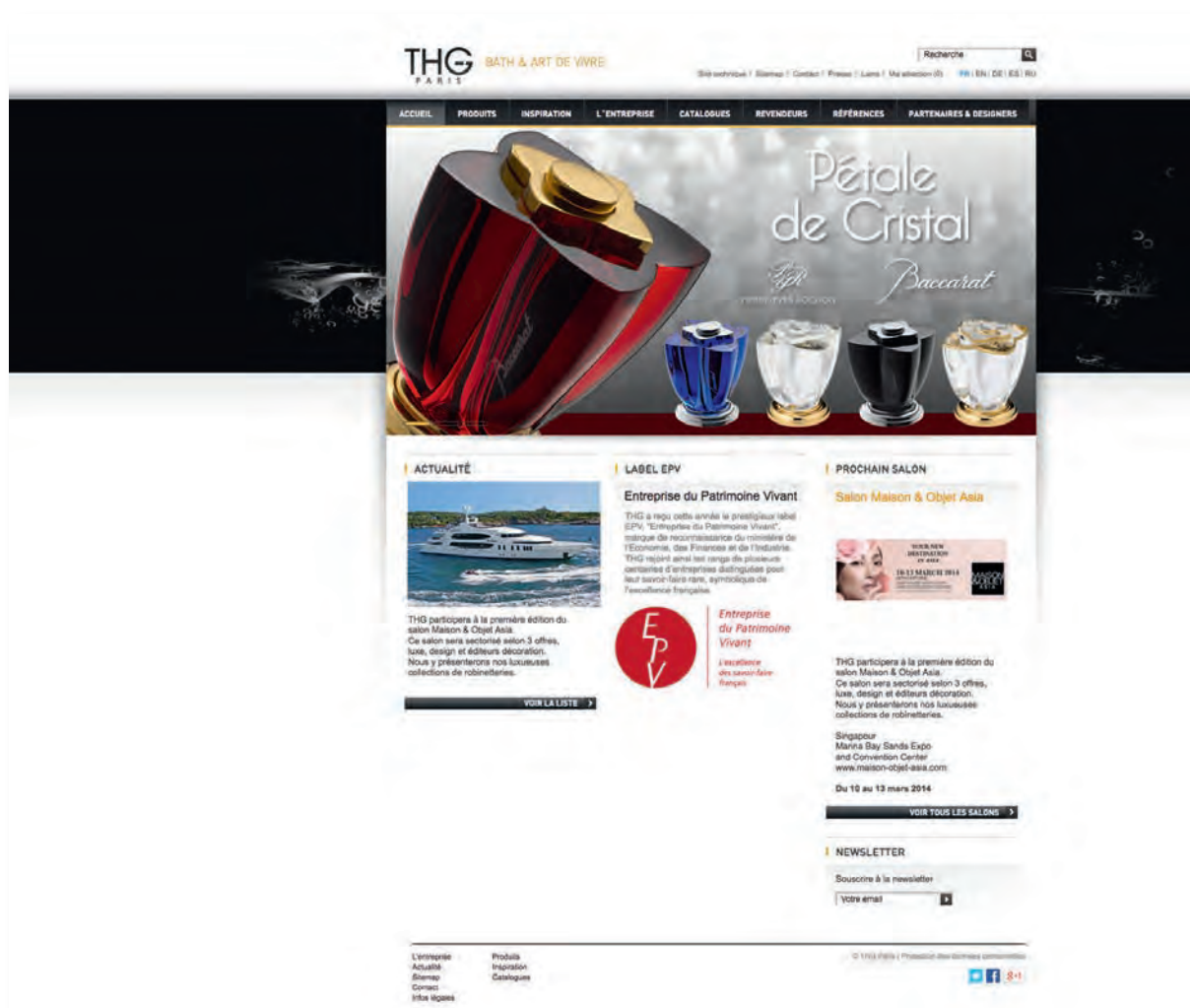

Nous sommes heureux de vous présenter notre nouveau site internet entièrement remodelé !

Disponible en quatre langues, nous l'avons repensé de A à Z afin de vous présenter tout le savoir-faire de THG en quelques clics et de vous offrir une source d'inspiration sans limite, ainsi qu'un outil de travail efficace.

Vous pourrez y découvrir toute notre actualité, nos nouveautés, la liste de nos revendeurs par pays, nos partenaires et designers, les salons où vous pourrez nous rencontrer, les nouveaux projets qui nous ont été confiés, sans oublier la gamme complète THG et toutes nos collections... et bien plus encore !

Suivez-aussi notre actualité sur Facebook, Twitter, ...

*We are pleased to present our new, entirely remodelled website.*

*Available in four languages, we have redesigned it from A to Z to introduce all THG's know-how in just a few clicks and provide you with a limitless source of inspiration, as well as an effective working tool.*

*It will give you details of all our latest news, our new products, a list of our dealers country by country, our partners and designers, the shows where you will be able to find us and the new projects entrusted to us, not forgetting THG's complete range and all our collections...and much more besides!*

*Follow us on Facebook, Twitter, ...*

Wir freuen uns, Ihnen unsere neu gestaltete Homepage vorzustellen.

Erstellt in vier verschiedenen Sprachen wurde die Internetseite von A bis Z völlig neu durchdacht, um Ihnen das gesamte Know-how von THG mit einigen Klicks präsentieren und Ihnen eine grenzenlose Inspirationsquelle sowie ein effizientes Arbeitswerkzeug anbieten zu können.

Sie haben die Möglichkeit, alle uns betreffenden News, unsere Neuheiten, die Liste mit unseren Händlern für jedes Land, unsere Partner und Designer, Messen, auf denen Sie uns antreffen können, neue Projekte, die uns anvertraut worden sind, sowie das umfassende THG-Sortiment und alle Kollektionen zu entdecken... und noch vieles mehr!

Folgen Sie uns auf Facebook, Twitter, ...

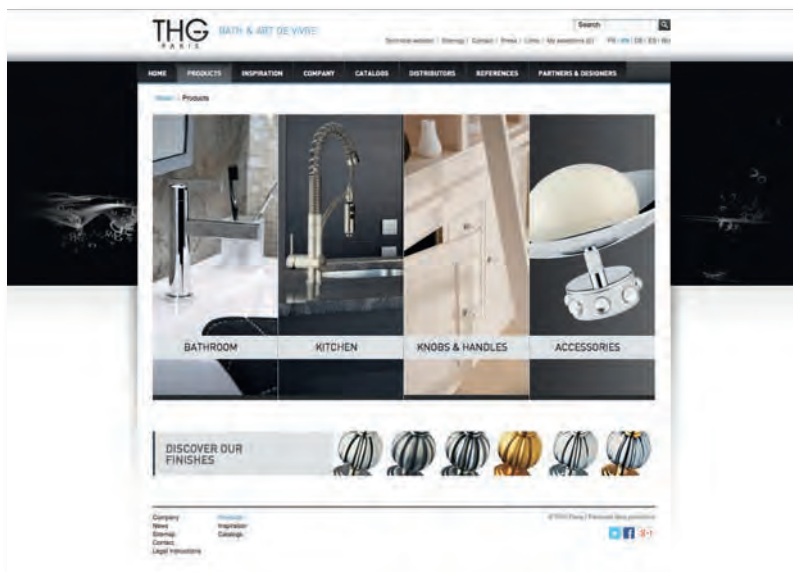

[www.thg.fr](http://www.thg.fr)

# LES FINITIONS / FINISHES / OBERFLÄCHEN



Chrome  
*Polished chrome*  
Chrom  
**A02**



Chromé mat  
*Matt chrome*  
Chrom matt  
**C02**



Chromé satiné  
*Satin chrome*  
Chrom satiniert  
**C03**



Doré  
*Polished gold*  
Gold  
**F01**



Doré mat non vernis  
*Uncoated matt gold*  
Gold matt unlackiert  
**F07**



Doré satiné  
*Satin gold*  
Gold satiniert  
**F03**



Nickel  
*Polished nickel*  
Silbernichel  
**B01**



Nickel mat  
*Matt nickel*  
Nickel matt  
**C01**



Nickel satiné  
*Satin nickel*  
Nickel satiniert  
**C05**



Luxbrass  
*Polished luxbrass*  
Edelmessing  
**H44**



Luxbrass mat  
*Matt luxbrass*  
Edelmessing matt  
**H16**



Luxbrass satiné  
*Satin luxbrass*  
Edelmessing satiniert  
**H12**



Argent rhodié  
*Rhodium silver*  
Silber Rhodium  
**F18**



Argent mat rhodié  
*Matt rhodium silver*  
Silber matt Rhodium  
**F19**



Aranja  
*Aranja*  
Aranja  
**D24**



Aranja mat  
*Matt aranja*  
Aranja matt  
**H17**



Laiton poli  
*Unlaquered brass*  
Messing polié unlackiert  
**C27**



Laiton poli verni  
*Polished & coated brass*  
Messing polié lackiert  
**D12**



Vieil argent verni brillant  
*Varnished antique silver*  
Altsilber lackiert  
**H03**



Vieil argent verni mat  
*Varnished matt antique silver*  
Altsilber matt lackiert  
**H08**



Vieux nickel  
*Antique nickel*  
Altnickel  
**H28**



Bronze vieilli ciré  
*Old oil rubbed bronze*  
Altbronze polié  
**D21**



Bronze clair verni brillant  
*Varnished clear bronze*  
Bronze hell  
**D01**



Bronze clair verni mat  
*Varnished matt bronze*  
Bronze hell matt  
**D05**

**THG**<sup>®</sup>  
P A R I S

## THG France

35, rue Tournière - BP 80212  
Béthencourt sur Mer  
80535 Friville cedex - France  
Tel. +33 (0)3 22 60 20 80  
Fax +33 (0)3 22 26 41 01  
Email : [contact@thg.fr](mailto:contact@thg.fr)  
[www.thg.fr](http://www.thg.fr)

## THG USA

6601 Lyons Road  
Coconut Creek  
FL 33073 - USA  
Tel 954 425 8225  
Fax 954 425 8301  
Email: [info@thgusa.com](mailto:info@thgusa.com)  
[www.thgusa.com](http://www.thgusa.com)

## THG Deutschland GmbH

Gutleutstr. 96  
60329 Frankfurt/Main  
Deutschland  
Tel +49 (0)69/ 25 78 14 33  
Fax +49 (0)69/ 25 78 14 35  
Email: [info@thg-deutschland.de](mailto:info@thg-deutschland.de)  
[www.thg-deutschland.de](http://www.thg-deutschland.de)

## THG Asia Pacific

Room 1202, JinHang Tower  
83 Wan Hang Du Road, Shanghai - PRC  
中国上海静安区万航渡路83号金航大厦1202室  
Tel. +86 (21) 61352738  
Fax +86 (21) 61352737  
Email: [contact@thg-asia.cn](mailto:contact@thg-asia.cn)  
[www.thg.fr](http://www.thg.fr)

© Photos : Didier Grieu / Guillaume Crochez / BB3D / Agence Pernet (p. 34-35) / MGM Marbles & Stones (p. 61-66-124-128) / Xavier Béjot (O. Putman) / François Gelly (Keppler) / Marc Bérenguer (Cheval Blanc - K2) - Despatin & Gobelli (O. Gagnère) / Christian Moser (Ch. Thomass) - Conception et réalisation : THG - Impression : Grupaprint - Edition mars 2014  
Remerciements : Baccarat / Lalique / Daum / Bernardaud / Christofle / Studio Putman / Chantal Thomass / Pierre-Yves Rochon / Jamie Drake / Olivier Gagnère / Cabinet Alberto Pinto / Olivier Gossart / Benetti / MGM Marbles & Stones

Textes et photos non contractuels et susceptibles d'être modifiés sans préavis  
Texts and pictures are not binding and can be modified without any previous notice / Texte und Fotos sind nicht Vertragsbestandteil und sind Änderungen vorbehalten





[www.thg.fr](http://www.thg.fr)